

ABB 05

ABACO® BLOCK BUS 5 slots

TECHNICAL MANUAL

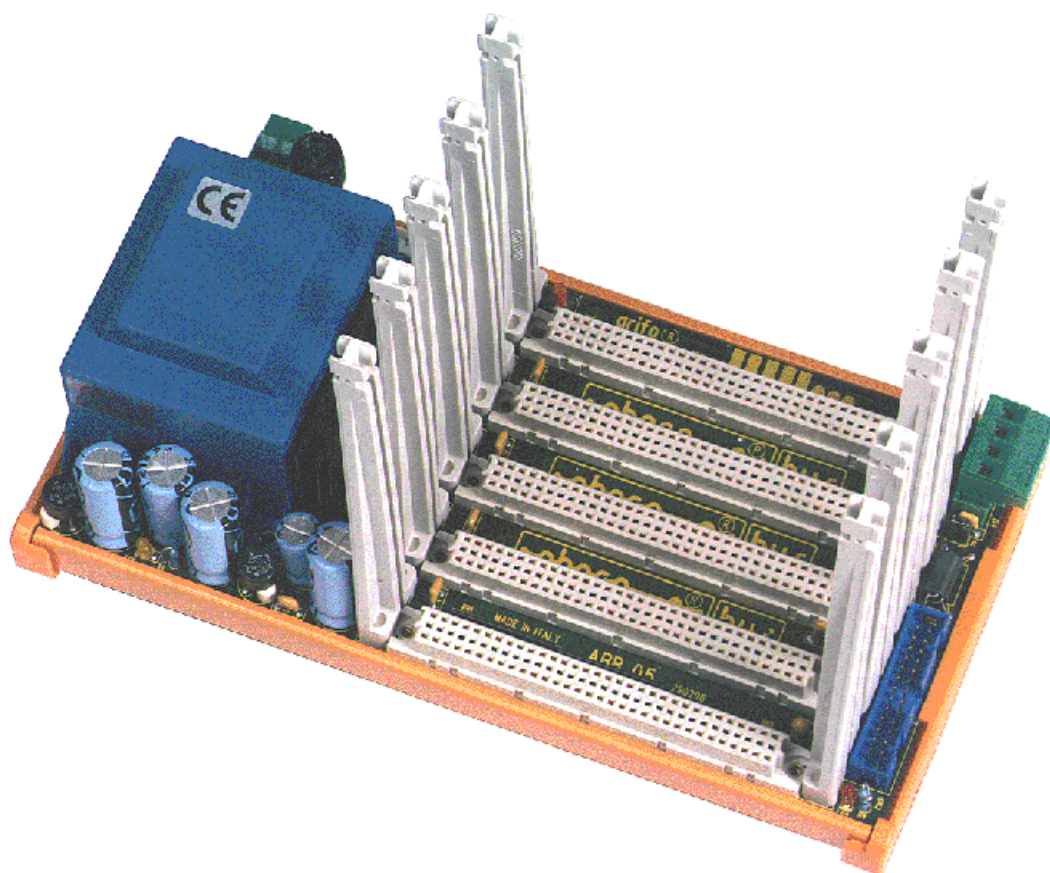

grifo®

ITALIAN TECHNOLOGY

Via dell' Artigiano, 8/6
40016 San Giorgio di Piano
(Bologna) ITALY

E-mail: grifo@grifo.it

<http://www.grifo.it>

<http://www.grifo.com>

Tel. +39 051 892.052 (a. r.)

FAX: +39 051 893.661



ABB 05

Edition 5.20

Rel. 14 February 2001

 , GPC® , grifo® , are trade marks of grifo®

ABB 05

ABACO® BLOCK BUS 5 slots

TECHNICAL MANUAL

Dimension: **210x150x110 mm** complete of plastic support for Ω rails **DIN 46277-1** and **DIN 46277-3**; 5 slots for **Abaco® BUS** cards in Euro size (100x160 mm) standard format, with **DIN 41612 A+C**, type C, connectors; 5 couples of rails for single Europe size cards; 26 pins connector for **Abaco® I/O BUS** mechanically and electrically linkable to every cards provided of this interface; termination resistors on the BUS line to ensure the correct functionality with not connected signals and CMOS interfaces; **2 LEDs** for showing status of power suppliers; local key for **RESET**; quick release screw terminal connectors for power supply voltages connection, one of these is arranged for **UPS 12** connection obtaining an uninterruptible power system; Double power supply section with protection against hightemperature, overloads and high voltages through **TransZorb™**, provided of noise filters and protection fuse; available in two different version:

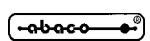
Code	Voltages in	Voltages out
ABB 05	230 Vac	+5 Vdc 2,0A; +24 Vdc 12,5 W
ABB 05.18VA	15÷18 Vac; 15÷18 Vac	+5 Vdc 2,0A; +24 Vdc 12,5 W

Available, in great quantity, without power supply section and different configurations.

grifo®

ITALIAN TECHNOLOGY

Via dell' Artigiano, 8/6
40016 San Giorgio di Piano
(Bologna) ITALY

E-mail: grifo@grifo.it

<http://www.grifo.it>

<http://www.grifo.com>

Tel. +39 051 892.052 (a. r.)

FAX: +39 051 893.661



ABB 05

Edition 5.20

Rel. 14 February 2001

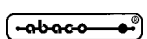
, **GPC®**, **grifo®**, are trade marks of **grifo®**

DOCUMENTATION COPYRIGHT BY grifo®, ALL RIGHTS RESERVED

No part of this document may be reproduced, transmitted, transcribed, stored in a retrieval system, or translated into any language or computer language, in any form or by any means, either electronic, mechanical, magnetic, optical, chemical, manual, or otherwise, without the prior written consent of **grifo®**.

IMPORTANT

Although all the information contained herein have been carefully verified, **grifo®** assumes no responsibility for errors that might appear in this document, or for damage to things or persons resulting from technical errors, omission and improper use of this manual and of the related software and hardware.

grifo® reserves the right to change the contents and form of this document, as well as the features and specification of its products at any time, without prior notice, to obtain always the best product.

For specific informations on the components mounted on the card, please refer to the Data Book of the builder or second sources.

SYMBOLS DESCRIPTION

In the manual could appear the following symbols:



Attention: Generic danger



Attention: High voltage

Trade Marks

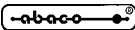
, **GPC®**, **grifo®** : are trade marks of **grifo®**.

Other Product and Company names listed, are trade marks of their respective companies.

GENERAL INDEX

INTRODUCTION	1
CARD VERSION	1
GENERAL INFORMATIONS	2
TECHNICAL FEATURES	4
GENERAL FEATURES	4
PHYSICAL FEATURES	4
ELECTRIC FEATURES	5
INSTALLATION	6
CONNECTIONS	6
CN2 - POWER SUPPLY FOR EXTERNAL LOADS CONNECTOR	6
CN1 - MAINS POWER SUPPLY CONNECTOR	7
CN1 - LOW VOLTAGE POWER SUPPLY CONNECTOR	7
CN3 - OPTO SUPPLY FETCH CONNECTOR	8
CN4 - STABILIZED SUPPLY VOLTAGES CONNECTOR	8
CN5 - ABACO® I/O BUS CONNECTOR	10
K1, K2, K3, K4, K5 - ABACO® BUS CONNECTORS	12
VISUAL SIGNALATIONS	14
JUMPER	14
RESET KEY	16
TERMINATION RESISTORS	16
BOARD CONNECTIONS	16
SUPPLY VOLTAGES SELECTION	17
EXTERNAL CARDS	18
BIBLIOGRAPHY	23
APPENDIX A: ALPHABETICAL INDEX	A-1

FIGURES INDEX

FIGURE 1: ABB 05 BLOCK DIAGRAM	3
FIGURE 2: CN3 - AUXILIARY POWER SUPPLY CONNECTOR	6
FIGURE 3: CN1 - MAINS POWER SUPPLY CONNECTOR	7
FIGURE 4: CN1 - LOW VOLTAGEPOWER SUPPLY CONNECTOR	7
FIGURE 5: J2 - OPTO SUPPLY FETCH CONNECTOR	8
FIGURE 6: CN4 - STABILIZED SUPPLY VOLTAGES CONNECTOR	8
FIGURE 7: LEDs, CONNECTORS, JUMPER, RESET KEY, ETC. LOCATION	9
FIGURE 8: CN5 - ABACO® I/O BUS CONNECTOR	10
FIGURE 9: CARD PHOTO	11
FIGURE 10: K1, K2, K3, K4, K5 - ABACO® BUS CONNECTORS	12
FIGURE 11: VISUAL SIGNALATIONS TABLE	14
FIGURE 12: JUMPERS SUMMARIZING TABLE	14
FIGURE 13: COMPONENTS MAP	15
FIGURE 14: POSSIBLE CONNECTIONS DIAGRAM	21

INTRODUCTION

The use of these devices has turned - IN EXCLUSIVE WAY - to specialized personnel.

The purpose of this handbook is to give the necessary information to the cognizant and sure use of the products. They are the result of a continual and systematic elaboration of data and technical tests saved and validated from the manufacturer, related to the inside modes of certainty and quality of the information.

The reported data are destined- IN EXCLUSIVE WAY- to specialized users, that can interact with the devices in safety conditions for the persons, for the machine and for the environment, impersonating an elementary diagnostic of breakdowns and of malfunction conditions by performing simple functional verify operations , in the height respect of the actual safety and health norms.

The informations for the installation, the assemblage, the dismantlement, the handling, the adjustment, the reparation and the contingent accessories, devices etc. installation are destined - and then executable - always and in exclusive way from specialized warned and educated personnel, or directly from the TECHNICAL AUTHORIZED ASSISTANCE, in the height respect of the manufacturer recommendations and the actual safety and health norms.

The devices can't be used outside a box. The user must always insert the cards in a container that respect the actual safety normative. The protection of this container is not threshold to the only atmospheric agents, but specially to mechanic, electric, magnetic, etc. ones.

To be on good terms with the products, is necessary guarantee legibility and conservation of the manual, also for future references. In case of deterioration or more easily for technical updates, consult the AUTHORIZED TECHNICAL ASSISTANCE directly.

To prevent problems during card utilization, it is a good practice to read carefully all the informations of this manual. After this reading, the user can use the general index and the alphabetical index, respectly at the begining and at the end of the manual, to find information in a faster and more easy way.

CARD VERSION

The present manual is reported to the boards **ABB 05** version **110298** and later .

The validity of the bring informations is subordinate to the number of the card release. The user must always verify the correct correspondence among the two denotations. Version number is printed on the boards in several positions both in serigraph and in printed circuit (for example in the bottom right corner, between connectors K1 and K2, on the component side).

GENERAL INFORMATION

The **ABB 05** mother board belongs to the **BLOCK** modules serie; it interconnects different **grifo**[®] cards and it generates the necessary power supply voltages. This card is equipped with: 5 slots motherboard section for **Abaco**[®] **BUS**; double power supply section both for CPU and I/O optocoupled sections; 26 pins expansion connector for **Abaco**[®] **I/O BUS**; mechanical rails for Euro cards; container equipped with hooks for Ω rails, normally available into electrical panels.

The use of **ABB 05** module allows to put the complete control unit into the electrical panel without being obliged to use a structure like **3HE Rack**. This solution means cheaper costs for the entire economy of the equipment and remarkable practicality of use. In addition to that, the presence of two power supply sections on board, reduces to the minimum the cabling mistakes and allows further optimization in costs and dimension otherwise not possible with different solutions. An additional important feature to the above mentioned 5 slots for **Abaco**[®] **BUS** is a 26 pins connector for **Abaco**[®] **I/O BUS** placed on the external side of the card which allows the immediate interface to any of the type 3 and 4 CPU cards (i.e **GPC**[®] **153**, **GPC**[®] **184**, **GPC**[®] **324**, **GPC**[®] **553**, etc.) or to any **BLOCK** peripheral cards (i.e **CAN 14**, **ADC 812**, **ETI 324**, etc.). Through the 26 pins connector the **ABB 05** supplies the power to the external card and it is possible to put all the cards on the same housing for Ω rails obtaining, in this way, a compact unit.

A suited power supply section generates 24Vdc suitable for supplying the optocoupled section of the input modules, if any. The section that generates +5Vdc and the section that generates 24Vdc are, between them, galvanically insulated. So the **ABB 05** offers the possibility to implement a small electronic unit without adding anything else the cards suitable for the application.

- Size: **210x150x110 mm** complete of plastic support for mounting on Ω rails **DIN 46277-1** and **DIN 46277-3**.
- 5 slots for **Abaco**[®] **BUS** cards in Euro size (100x160 mm) standard format, with **DIN 41612 A+C**, type C, connectors.
- 5 couples of rails for single Europe size cards.
- 26 pins connector for **Abaco**[®] **I/O BUS** mechanically and electrically linkable to every cards provided of this interface.
- Termination resistors on the BUS line to ensure the correct functionality with not connected signals and CMOS interfaces.
- **2 LEDs** for showing status of power suppliers.
- Local key for **RESET**.
- Quick release screw terminal connectors for power supply voltages connection; one of these is arranged for **UPS 12** connection obtaining an uninterruptible power system.
- Double power supply section with protection against hightemperature, overloads and high voltages through **TransZorb**[™], provided of noise filters and protection fuse.
- Available in two different version:

Code	Required voltages	Generated voltages
ABB 05	230 Vac	+5 Vdc 2.0A; +24 Vdc 12.5 W
ABB 05.18VA	15÷18 Vac; 15÷18 Vac	+5 Vdc 2.0A; +24 Vdc 12.5 W

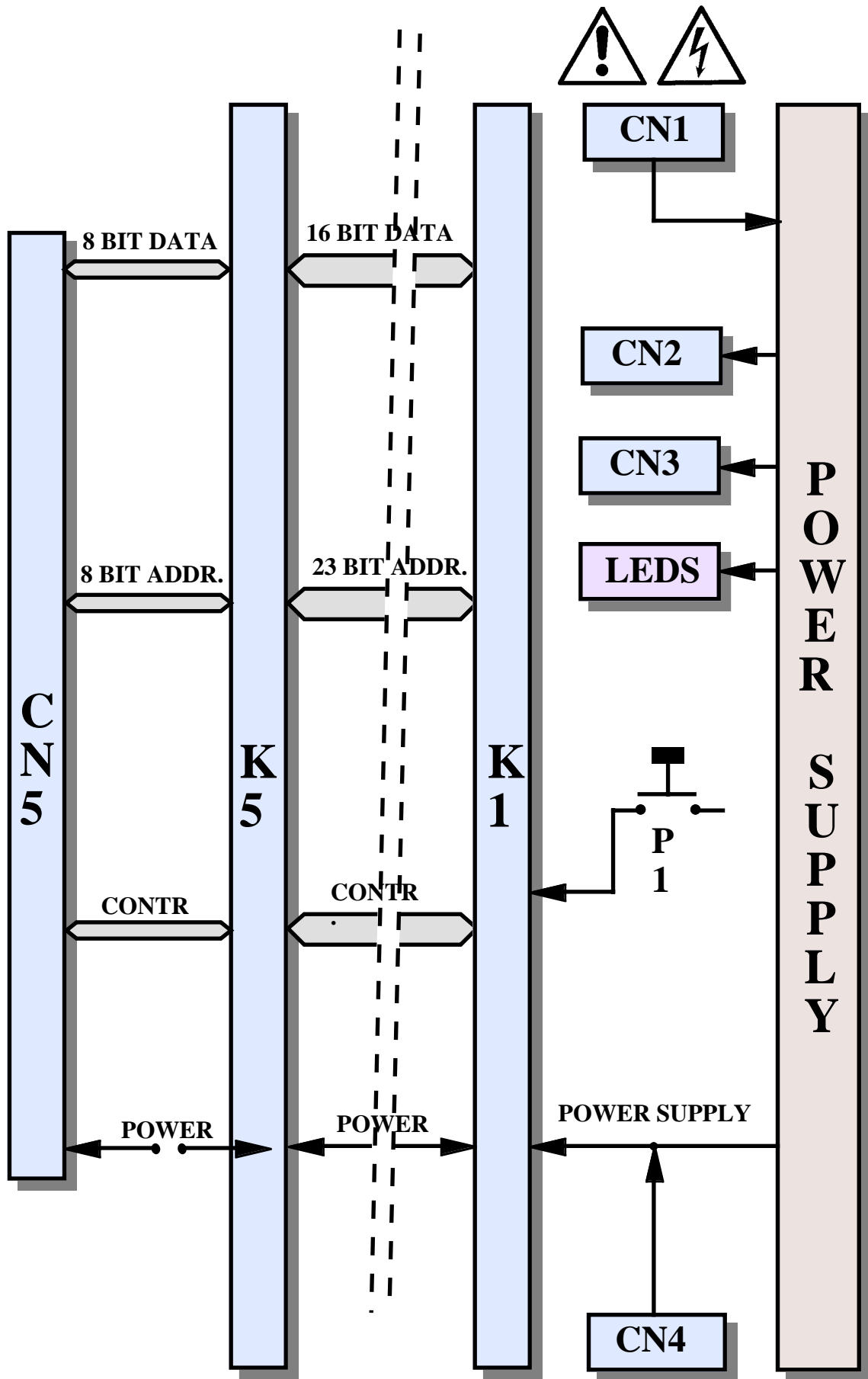

FIGURE 1: ABB 05 BLOCK DIAGRAM

TECHNICAL FEATURES

GENERAL FEATURES

BUS type:	ABACO® and ABACO® I/O
On board resources:	5 slots for BUS ABACO® BUS 1 connector for ABACO® I/O BUS 1 power supply section for digital electronics (+5 Vdc) 1 power supply section for field electronics (+24 Vdc) 1 reset key 2 LEDs to visualize the status of generated voltages
BUS signals:	Provided with termination resistors
Power supply:	Provided with noise suppressor filter

PHYSICAL FEATURES

Connectors:	K1: 64 pins DIN 41612 A+C type C K2: 64 pins DIN 41612 A+C type C K3: 64 pins DIN 41612 A+C type C K4: 64 pins DIN 41612 A+C type C K5: 64 pins DIN 41612 A+C type C CN1: 2 or 4 pins quick release screw terminal CN2: 5 pins low profile vertical male CN3: 2 pins screw terminal CN4: 4 pins quick release screw terminal CN5: 26 pins low profile vertical male
Size (WxHxD):	210x150x110 mm
Slots pitch:	4 TE
Weight:	1120 g
Temperature range:	from 0 to 70 Centigrad degrees
Relative humidity:	from 20% to 90% (without condensing)

ELECTRIC FEATURES

Fuse F1	1 A;	250 V delayed
Fuse F2	200 mA;	250 V delayed
Fuse F3	1 A;	250 V delayed

Mains power supply version

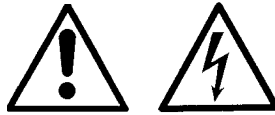

Voltage required:

230 Vac +6-10% 50 Hz

Voltages provided:

+5 Vdc	10 W (2.0 A)	(*)
+V Opto	12.5 W	(*)

Low voltage power supply version

Voltages required:

V2 (+5 Vdc)	15÷18 Vac
V1 (+V Opto)	15÷18 Vac

Voltages provided:

+5 Vdc	10 W (2.0 A)	(*)
+V Opto	12.5 W	(*)

(*) Values referred to a working temperature of 20 °C

INSTALLATION

In this chapter there are information for a right installation and correct use of mother board **ABB 05**. The User can find the location and functions of each connector and some explanatory diagrams.

CONNECTIONS

The **ABB 05** mother board has several connectors that can be linkeded to the other cards of the system or directly to the field, according to system requirements. In this paragraph there are connectors pin outs, a short signals description (including signals direction) and connectors location (please see figure 7).

CN2 - POWER SUPPLY FOR EXTERNAL LOADS CONNECTOR

CN2 is a 5 pins low profile vertical male 2.54 mm pitch connector. Because **ABB 05** is provided with on board power supply, the two galvanically isolated voltages generated by this section can be accessed through CN2, to supply external loads (for further information please see the paragraph “ SUPPLY VOLTAGES SELECTION”).

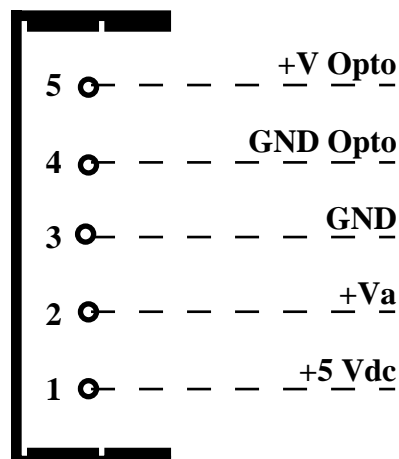

FIGURE 2: CN3 - AUXILIARY POWER SUPPLY CONNECTOR

Signals description:

+V Opto	=	○	- Positive terminal of external optocoupled I/O supply.
GND opto	=	○	- Common terminal of external optocoupled I/O supply.
GND	=	○	- Ground.
+Va	=	○	- Positive terminal of board switching supply input voltage.
+5 Vdc	=	○	- +5 Vdc supply signal.

CN1 - MAINS POWER SUPPLY CONNECTOR

CN1 is a 2 pins quick release screw terminal connector. Through CN1 mains voltage is provided to on board power supply section, properly configured (for further informations please see the paragraph “ SUPPLY VOLTAGES SELECTION”).

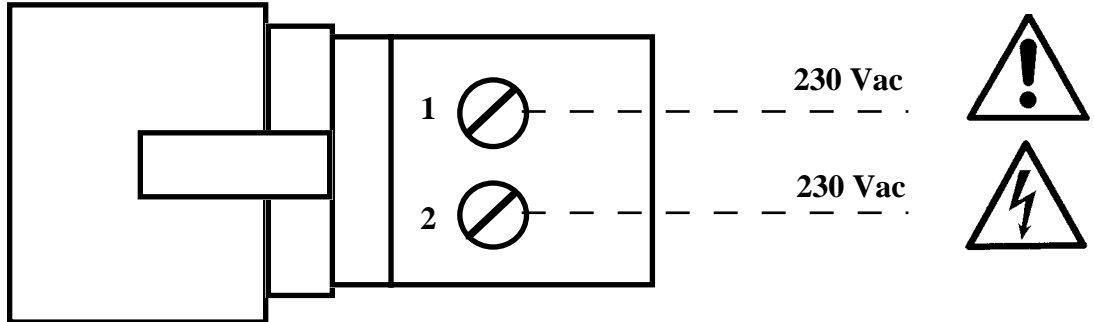

FIGURE 3: CN1 - MAINS POWER SUPPLY CONNECTOR

Signals description:

230 Vac = I - 230 Vac mains power supply signals.

CN1 - LOW VOLTAGE POWER SUPPLY CONNECTOR

CN1 is a 4 pins quick release screw terminal connector. Through CN1 low voltage is provided to on board power supply section, properly configured (for further informations please see the paragraph “ SUPPLY VOLTAGES SELECTION”).

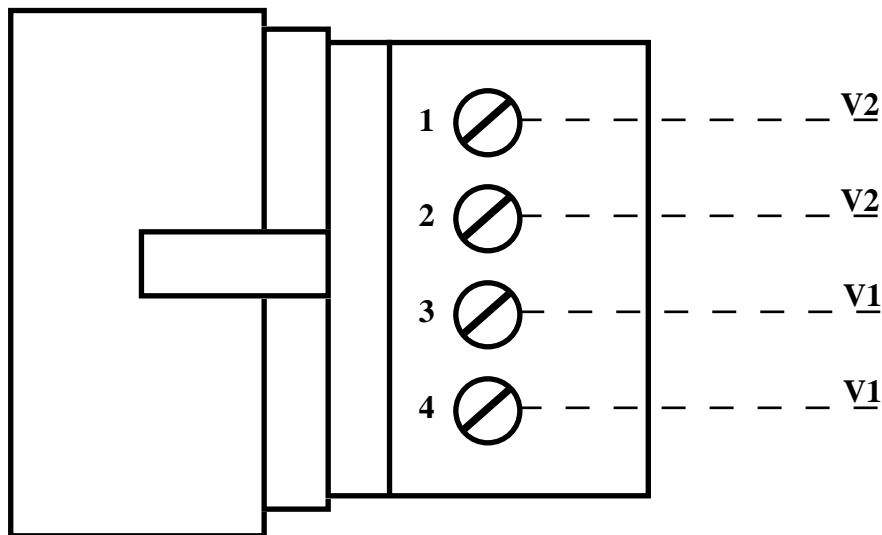

FIGURE 4: CN1 - LOW VOLTAGEPOWER SUPPLY CONNECTOR

Signals description:

V1 = I - +V Opto power supply.

V2 = I - +5 Vdc power supply.

CN3 - OPTO SUPPLY FETCH CONNECTOR

CN3 is a 2 pins quick release screw terminal connector.

Because **ABB 05** is provided with on board power supply, the **+V Opto** galvanically isolated voltage generated by this section can be accessed through CN3, to supply external optocoupled I/O (for further information please see the paragraph “ SUPPLY VOLTAGES SELECTION”).

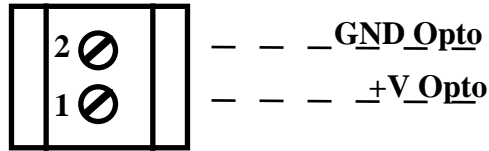

FIGURE 5: J2 - OPTO SUPPLY FETCH CONNECTOR

Signals description:

+V Opto = O - Positive terminal of external optocoupled I/O supply.
GND opto = - Common terminal of external optocoupled I/O supply.

CN4 - STABILIZED SUPPLY VOLTAGES CONNECTOR

CN4 is a 4 pins quick release screw terminal connector that provides **ABB 05** +12 Vdc and -12 Vdc supply voltages for industrial **ABACO® BUS** generated by an external stabilized power supply. This connector features a standard pin out for an easy installation, even in case of replacement of the mother board with a model having a greater or lower number of slots.

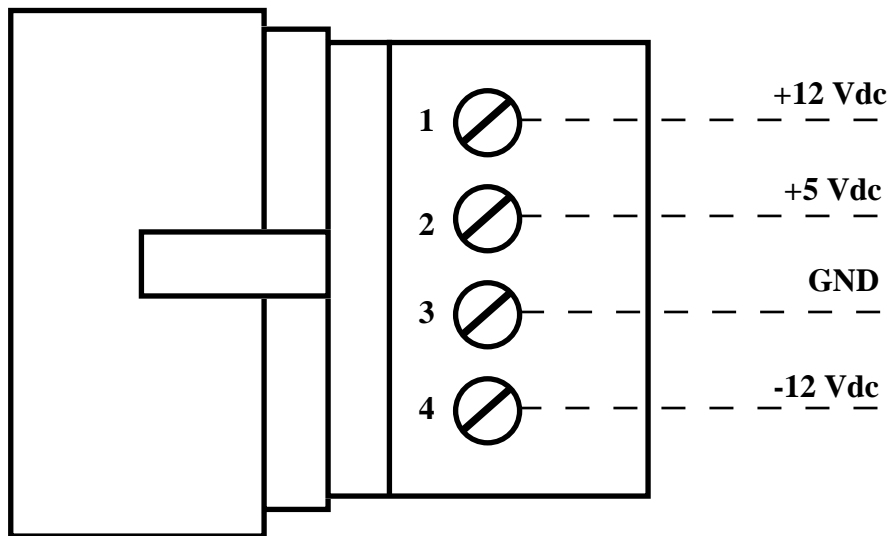

FIGURE 6: CN4 - STABILIZED SUPPLY VOLTAGES CONNECTOR

Signals description:

+5 Vdc = O - Supply +5 Vdc for **ABACO® BUS**.
+12 Vdc = I - Supply +12 Vdc for **BUS ABACO® BUS**.
-12 Vdc = I - Supply -12 Vdc for **BUS ABACO® BUS**.
GND = - Ground signal for **BUS ABACO® BUS**.

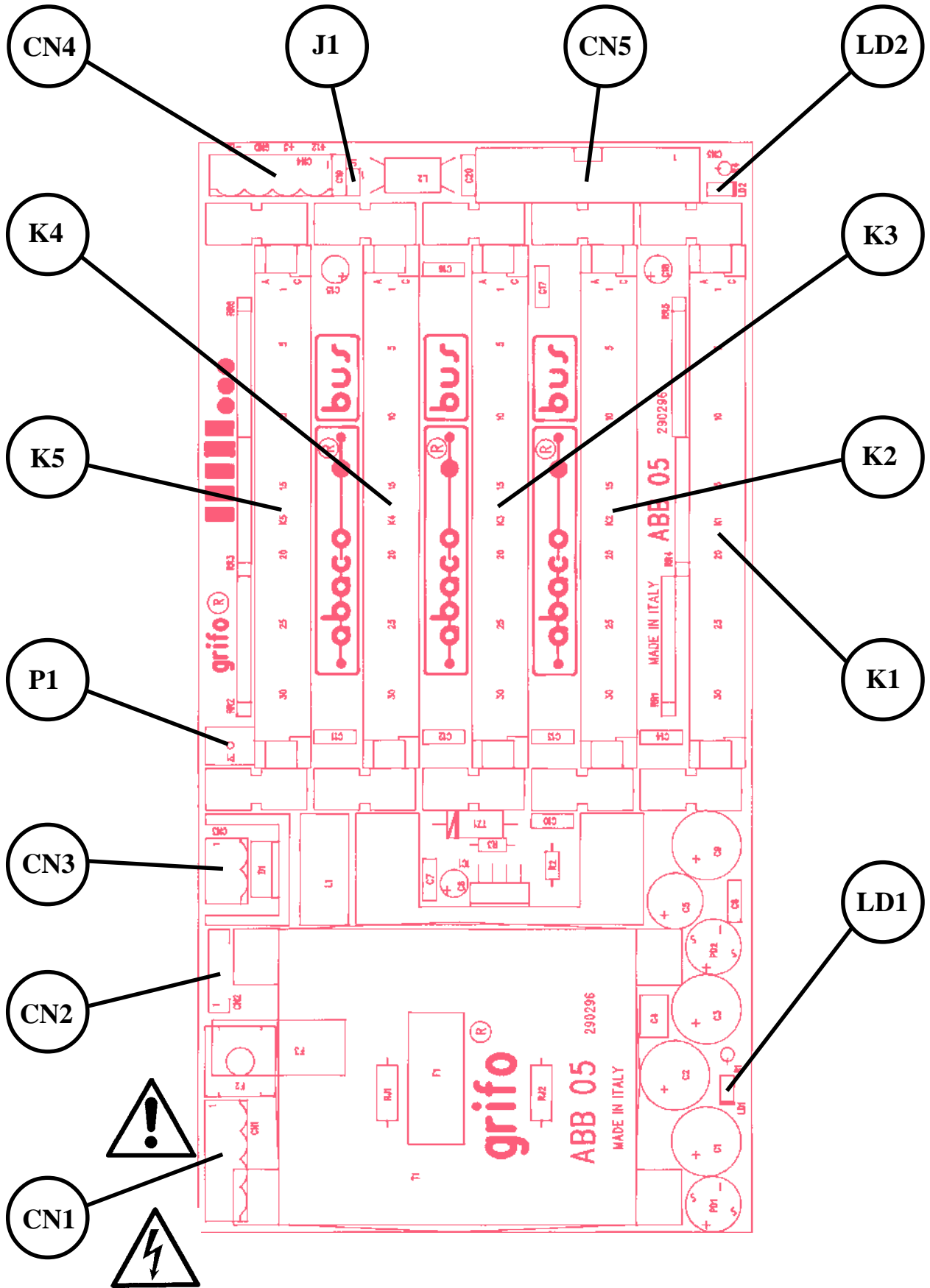

FIGURE 7: LEDs, CONNECTORS, JUMPER, RESET KEY, ETC. LOCATION

CN5 - ABACO® I/O BUS CONNECTOR

CN5 is a 26 pins, male, vertical, low profile connector with 2.54 mm pitch.

Through CN5 ABACO® I/O BUS cards and ABACO® BUS can be connected together. All this connector signals are at TTL level and follows the ABACO® I/O BUS standard.

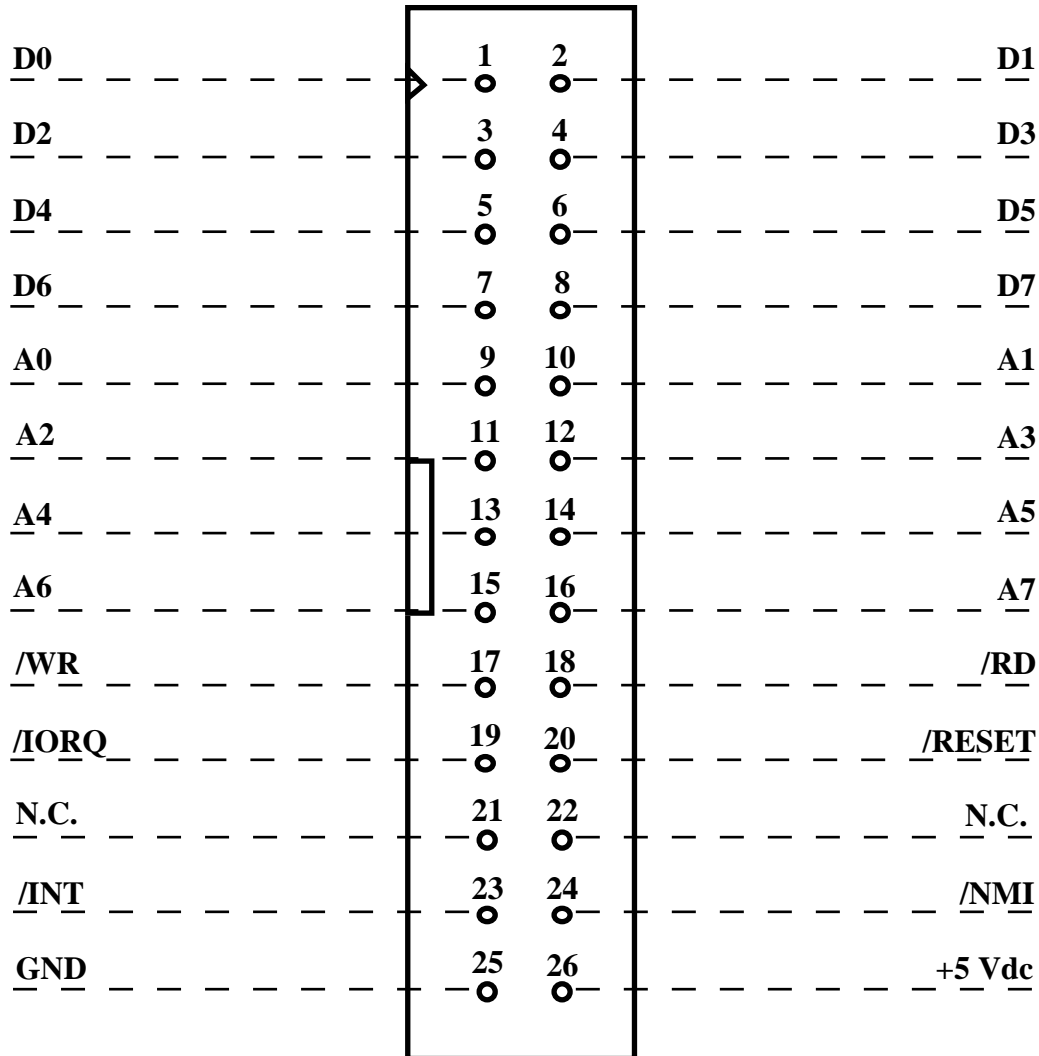

FIGURE 8: CN5 - ABACO® I/O BUS CONNECTOR

Signals description:

A0-A7	=	O	- Address BUS.
D0-D7	=	I/O	- Data BUS.
/INT	=	I	- Interrupt request (open collector type).
/NMI	=	I	- Non maskable interrupt (open collector type).
/IORQ	=	O	- Input output request.
/RD	=	O	- Read cycle status.
/WR	=	O	- Write cycle status.
/RESET	=	O	- Reset.
+5 Vdc	=	O	- +5 Vdc power supply.
GND	=		- Ground signal.
N.C.	=		- Not connected

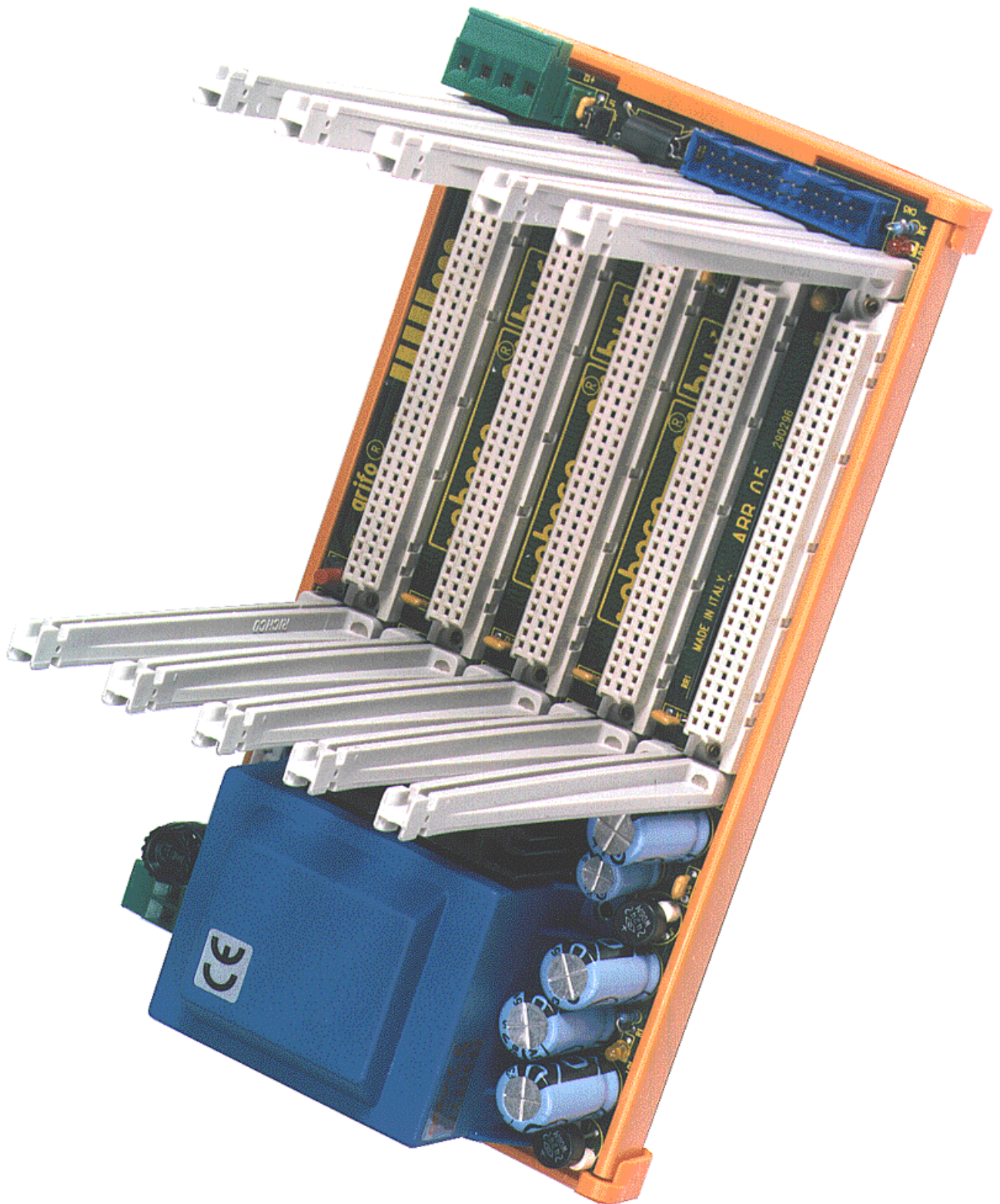

FIGURE 9: CARD PHOTO

K1, K2, K3, K4, K5 - ABACO® BUS CONNECTORS

K1, K2, K3, K4 and K5 are 64 pins DIN 41612 A+C type C female connectors, to interface with the industrial ABACO® BUS.

Here follows the standard 8 bits and 16 bits ABACO® BUS pin-out.

Please remark that all the signals here described are TTL, except for the power supplies.

A 16 bit BUS	A 8 bit BUS	PIN	C 8 bit BUS	C 16 bit BUS
GND	GND	1	GND	GND
+5 Vdc	+5 Vdc	2	+5 Vdc	+5 Vdc
D0	D0	3	-	D8
D1	D1	4	-	D9
D2	D2	5	-	D10
D3	D3	6	/INT	/INT
D4	D4	7	/NMI	/NMI
D5	D5	8	/HALT	D11
D6	D6	9	/MREQ	/MREQ
D7	D7	10	/IORQ	/IORQ
A0	A0	11	/RD	/RDLDS
A1	A1	12	/WR	/WRLDS
A2	A2	13	/BUSAK	D12
A3	A3	14	/WAIT	/WAIT
A4	A4	15	/BUSRQ	D13
A5	A5	16	/RESET	/RESET
A6	A6	17	/M1	/IACK
A7	A7	18	/RFSH	D14
A8	A8	19	/MEMDIS	/MEMDIS
A9	A9	20	VDUSEL	A22
A10	A10	21	/IEI	D15
A11	A11	22	-	-
A12	A12	23	CLK	CLK
A13	A13	24	-	/RDUDS
A14	A14	25	-	/WRUDS
A15	A15	26	-	A21
A16	-	27	-	A20
A17	-	28	-	A19
A18	-	29	/R.T.	/R.T.
+12 Vdc	+12 Vdc	30	-12 Vdc	-12 Vdc
+5 Vdc	+5 Vdc	31	+5 Vdc	+5 Vdc
GND	GND	32	GND	GND

FIGURE 10: K1, K2, K3, K4, K5 - ABACO® BUS CONNECTORS

Signals description:

8 bits CPU

A0-A15	=	O	- Address BUS
D0-D7	=	I/O	- Data BUS
INT	=	I	- Interrupt request
NMI	=	I	- Non Maskable Interrupt
HALT	=	O	- Halt state
MREQ	=	O	- Memory Request
IORQ	=	O	- Input Output Request
RD	=	O	- Read cycle status
WR	=	O	- Write cycle status
BUSAK	=	O	- BUS Acknowledge
WAIT	=	I	- Wait
BUSRQ	=	I	- BUS Request
RESET	=	O	- Reset
M1	=	O	- Machine cycle one
RFSH	=	O	- Refresh for dynamic RAM
MEMDIS	=	I	- Memory Display
VDUSEL	=	O	- VDU Selection
IEI	=	I	- Interrupt Enable Input
CLK	=	O	- System clock
R.B.	=	I	- Reset button
+5 Vdc	=	I	- Power supply at +5 Vdc
+12 Vdc	=	I	- Power supply at +12 Vdc
-12 Vdc	=	I	- Power supply at -12 Vdc
GND	=		- Ground signal

16 bits CPU

A16-A22	=	O	- Address BUS
D8-D15	=	I/O	- Data BUS
RD UDS	=	O	- Read Upper Data Strobe
WR UDS	=	O	- Write Upper Data Strobe
IACK	=	O	- Interrupt Acknowledge
RD LDS	=	O	- Read Lower Data Strobe
WR LDS	=	O	- Write Lower Data Strobe

NOTE

Directionality indications as above stated are referred to a master (**GPC**®) board and have been kept untouched to avoid ambiguity in case of multi-boards systems.

ABACO® BUS is not multimaster. Please remark that only one CPU intelligent control board can be installed in the **ABACO**® BUS and **ABACO**® I/O BUS chain.

VISUAL SIGNALATIONS

ABB 05 is provided with two signalation LEDs to show power supply status , as described in the following table:

LEDs	COLOUR	PURPOSE
LD1	Yellow	Indicates the presence of +V Opto.
LD2	Red	Indicates the presence of +5 Vdc.

FIGURE 11: VISUAL SIGNALATIONS TABLE

The main purpose of LEDs is to show a visual indication about the card's status, making so easier debug and verify operations.

To easily locate these visual signalations please refer to figure 7.

JUMPER

On **ABB 05** mother boards there is one 2 pins jumper to select how +5 Vdc is connected on CN5. Below there is the jumpers list, location and function.

JUMPER	CONNECTION	PURPOSE	DEF.
J1	not connected	It does not connect +5 Vdc (pin 26) of CN5 to +5 Vdc of ABB 05.	*
	connected	It connects +5 Vdc (pin 26) of CN5 to +5 Vdc of ABB 05.	

FIGURE 12: JUMPERS SUMMARIZING TABLE

To recognize these valid connections, please refer to the board printed diagram (serigraph) or to figure 13 of this manual, where the pins numeration is listed; for recognizing jumpers location, please refer to figure 7.

The "*" used in the following tables, denotes the default connection, or on the other hand the connection set up at the end of testing phase, that is the configuration the User receives.

NOTE

The function of jumper J1 is to avoid dangerous electric confilcts between +5 Vdc eventually supplied by **ABB 05** and the same signal of **ABACO® I/O BUS**, if the card connected is provided with its own supply source.

In addition, depending on the cards selected to build the application, the user can always optimize the power supply through this jumper.

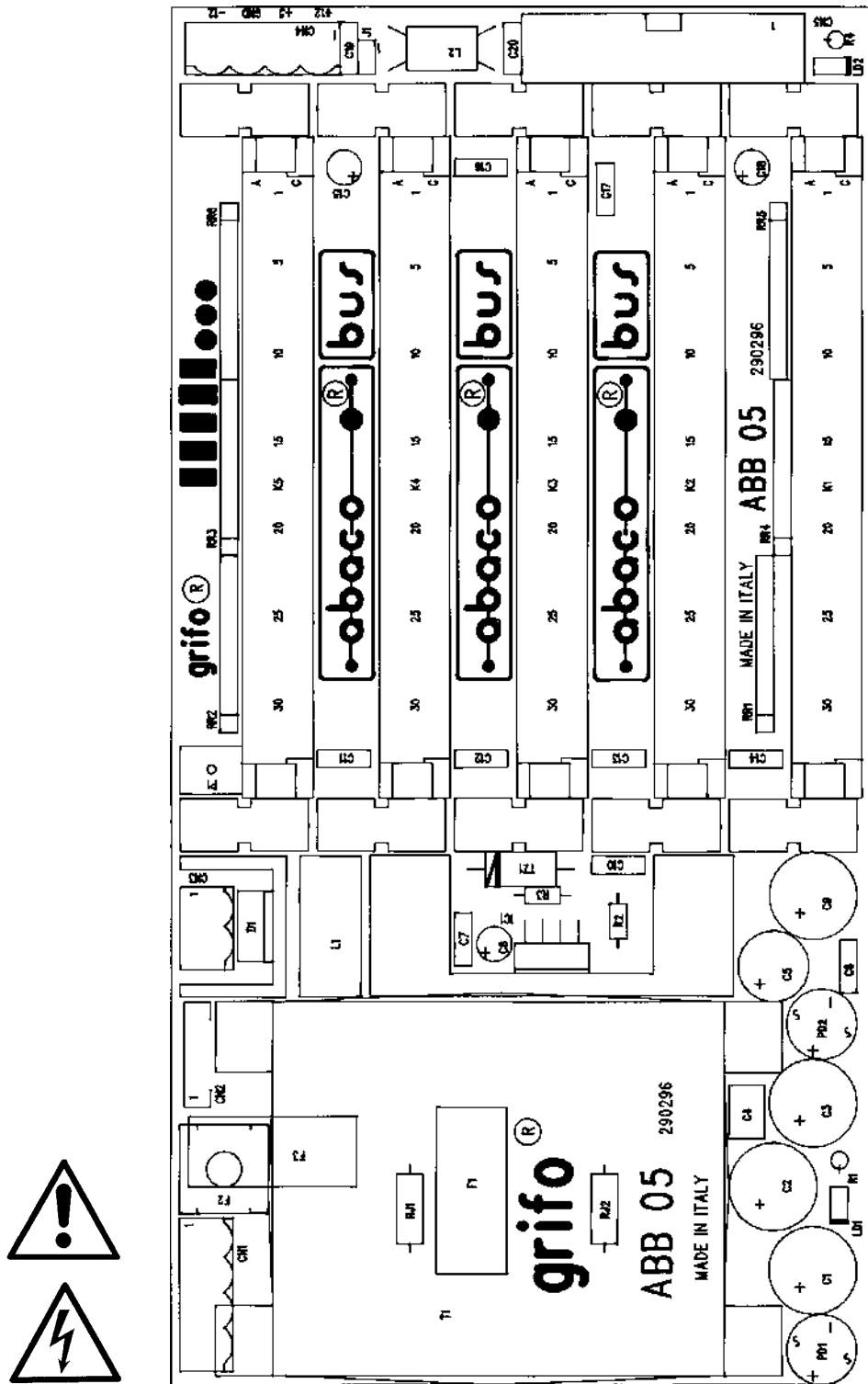

FIGURE 13: COMPONENTS MAP

RESET KEY

ABB 05 mother boards are provided with a reset key whose purpose is to activate the signal R. T. of industrial BUS **ABACO**® BUS. By means of this feature the user can easily reset the whole system installed on the modules, without any need to use an external tool. To easily locate the reset key please refer to figure 7.

TERMINATION RESISTORS

A very important feature of **ABB 05** mother boards is that all the signals of **ABACO**® BUS are provided with a termination resistor.

This feature minimizes the eventual effects due to signals that otherwise would remain floating and in the meantime it warrants the functionality and the perfect interfacing to all the **grifo**® industrial boards listing. Thanks to the termination resistors in fact, also boards provided with CMOS BUS interfaces can be connected, obtaining an overall reduction of the power consumption for the application system.

BOARD CONNECTIONS

To prevent possible connecting problems between **ABB 05** board and the external systems, the user has to read carefully the information of the previous paragraphs and he must follow these instructions:

- The TTL signals can be connected directly only to a device featuring the same type of interface. About the correspondance between logic signals and TTL output status, remember that a logic **0** generates a TTL 0 Vdc, while a logic **1** generates a TTL +5 Vdc.

SUPPLY VOLTAGES SELECTION

ABB 05 mother board is provided with an efficient power supply circuitry that is designed to solve in a comfortable way the problem to supply the system despite the condition of utilization. The power supply section includes: a switching that provides the voltage on +5 Vdc in any admitted condition of load and input tension; a simple rectifier group that generates +Vopto voltage suitable to supply the optocoupled input sections.

Here follow the two possible configurations of supply section:

- *Mains power supply (default configuration)*



In this configuration the board requires mains 230 Vac (+6% -10%) power supply that must be provided on the pins 1 and 2 of connector CN1. The board generates in autonomy the +5 Vdc and +Vopto keeping them galvanically isolated.

Maximum external loads are 2.0 A on +5 Vdc and 12.5 W on +V Opto.

- *Low voltage power supply (option **ABB 05.18VA**)*

In this configuration the board requires two 15÷18 Vac galvanically isolated tensions (normally available in control machines electric racks) that must be provided on the pins of connector CN2. The board generates in autonomy the +5 Vdc and +Vopto keeping them galvanically isolated. Maximum external loads are 2.0 A on +5 Vdc and 12.5 W on +V Opto, provided that, of course, the two external voltages are enough to supply also external loads.

Please remark that +V Opto voltage has a nominal value of +24 Vdc but being generated by a not stabilized rectifier section it may vary heavily. For this motivation across the whole manual the current value has never been reported, instead the value of power has been reported.

Interfacing systems through **ABACO® I/O BUS** external cards featuring their own power supply section (**GPC® 15R**, **ZBx xxx**, series **3** and **4**) may create conflicts on the +5 Vdc line. It is possible to isolate on board and external +5 Vdc signals disconnecting jumper J1. Please refer to paragraph “**JUMPER**” for further information.

In case of doubts about which power supply section to choice and the connections to perform, please contact **grifo®**. This need must be specified in the order, in fact this implies a different hardware configuration that must be performed by **grifo®** technicians. See the option indication in the text above to know which code is to be used to order the version desired.

EXTERNAL CARDS

ABB 05 mother board can interface to most of **grifo**[®] industrial boards. Their main purpose is to perform a digital Inpu/Output interfacement between CPU (**GPC**[®]) cards and the external world. Here is reported an illustrative list of cards capable to interact with **ABB 05** mother board with a short description of their features; for further informations please request the specific documentation.

SPB 04-SPB 08

Switch Power BUS 4-8 slots

Motherboard featuring 4-8 slots of **ABACO**[®] industrial BUS; pitch 4 TE; standard power supply connectors; termination resistances; connector type F for **SPC xxx** supply ; holes for rack docking.

SBP 02-xx

Switch BLOCK Power xx version

Low cost switching power supply able to generate voltage from +5 to +40 Vdc and current up to 2.5 A; Input from 12 to 24 Vac; Connection for DIN C Type and Ω rails.

JMS 34

Jumbo Multifunction Support for Axis control

Generic peripheral axis control card. 3 optocoupled acquisition channels, with 16 bits bidirectional counter, for incremental encoder. 4 12bits ± 10 Vdc D/A channels. 8 Opto-in; 8 NPN Opto-output 40Vdc 500 mA. All I/O lines displayed with LEDs.

IPC 52

Intelligent Peripheral Controller, 24 analogic input

This intelligent peripheral card acquires 24 independent analogic input lines: 8 PT 100 or PT 1000 sensors, 8 J,K,S,T termocouples, 8 analog input ± 2 Vdc or $4 \div 20$ mA; 16 bits + sign A/D section; 0.1 °C resolution; 32K RAM for local data logging; buzzer; 16 TTL I/O lines; 5 or 8 conversion per second; facility of networking up to 127 IPC 52 cards using serial line. BUS interfacing or through RS 232, RS 422, RS 485 or current loop line. Only 5Vdc power supply.

GPC[®] 51

General Purpose Controller fam. 51

Microprocessor family 51 INTEL including the masked BASIC chip; the board features: 16 I/O TTL lines; dip switch; 3 timer/counter; RS 232; 4 A/D converter signals resolution 11 bit; buzzer; on board EPROM programmer; RTC and 32K SRAM with Lithium battery back up; controller for display and keyboard.

GPC[®] 188F

General Purpose Controller 80C188

80C188 μ P 20MHz; 1 RS 232 line; 1 RS 232, RS 422-485 or Current Loop line; 24 TTL I/O lines; 1M EPROM or 512K FLASH; 1M RAM Lithium battery backed; 8K serial EEPROM; RTC; Watch Dog; 8 Dip switch; 3 Timer Counter; 8 13 bit A/D lines; Power failure; activity LEDs; single power supply +5Vdc.

GPC[®] 150

General Purpose Controller 84C15

Microprocessor Z80 at 16 MHz; implementation completely CMOS; 512K EPROM or FLASH; 512K SRAM; RTC; Back-Up through external Lithium battery; 4M serial FLASH ; 1 serial line RS 232 plus 1 RS 232 or RS 422-485 or current loop; 40 I/O TTL; 2 timer/counter; 2 watch dog; dip switch; EEPROM; A/D converter with resolution 12 bit; activity LED.

GPC® 15R

General Purpose Controller 84C15

84C15 μ P, 10÷16 MHz; 1 RS 232 line; 1 RS 232 or RS 422-485 or C. L. line; 16÷24 TTL I/O lines; 16 Opto-in; 8 Relays; 4 Opto Coupled Timers Counters; 512K EPROM or FLASH; 512K RAM and RTC backed; 8K serial EEPROM; 8K Backed RAM modul; Buzzer; 1 Activity LED; Watch dog; 4÷12 readable DIPs; LCD Interface.

GPC® 15A

General Purpose Controller 84C15

Full CMOS card, 10÷20 MHz 84C15 CPU; 512K EPROM or FLASH; 128K RAM; 8K RAM and RTC backed; 8K serial EEPROM; 1 RS 232 line; 1 RS 232 line or RS 422-485 or Current Loop line; 32 or 40 TTL I/O lines; CTC; Watch dog; 2 Dip switches; Buzzer.

GPC® 15A

General Purpose Controller 84C15

Full CMOS card, 10÷20 MHz 84C15 CPU; 512K EPROM or FLASH; 128K RAM; 8K RAM and RTC backed; 8K serial EEPROM; 1 RS 232 line; 1 RS 232 line or RS 422-485 or Current Loop line; 32 or 40 TTL I/O lines; CTC; Watch dog; 2 Dip switches; Buzzer.

GPC® 323

General Purpose Controller 51 family

80C32 μ P, 14 MHz; Full CMOS; 1 RS 232 line (software); 1 RS 232 or RS 422-485 or Current Loop line; 24 TTL I/O lines; 11 A/D 12 bits lines; 3 Timers Counters; 64K EPROM; 64K RAM; 32K RAM and RTC backed; 32K DIL EEPROM; 8K serial EEPROM; Buzzer; 2 Activity LED; Watch dog; 5 readable DIPs; LCD Interface.

GPC® 553

General Purpose Controller 80C552

80C552 μ P, 22÷33 MHz; 1 RS 232 line (software); 1 RS 232 or RS 422-485 or Current Loop line; 16 TTL I/O lines; 8 A/D 10 bits lines; 3 Timers Counters; 64K EPROM; 64K RAM; 32K RAM and RTC backed; 32K DIL EEPROM; 8K serial EEPROM; 2 PWM lines; 1 Activity LED; Watch dog; 5 readable DIPs; LCD Interface.

GPC® 153

General Purpose Controller Z80

84C15 μ P, 10÷16 MHz; Full CMOS; 1 RS 232 line; 1 RS 232 or RS 422-485 or Current Loop line; 16 TTL I/O lines; 8 A/D 12 bits lines; 2÷4 Timers Counters; 512K EPROM or FLASH; 512K RAM and RTC backed; 8K serial EEPROM; Buzzer; 1 Activity LED; Watch dog; 8 readable DIPs; LCD Interface.

GPC® 183

General Purpose Controller Z180

Z180 μ P, 10÷16 MHz; Full CMOS; 1 RS 232 line; 1 RS 232 or RS 422-485 or Current Loop line; 24 TTL I/O lines; 11 A/D 12 bits lines; 2 Timers Counters; 512K EPROM or FLASH; 512K RAM and RTC backed; 8K serial EEPROM; Buzzer; 2 Activity LED; Watch dog; 4 readable DIPs; LCD Interface.

GPC® 324/D

“4” Type General Purpose Controller 80C32/320

80C32 or 80C320 μ P, 14÷22 MHz; Full CMOS; 1 RS 232 line; 1 RS 232 or RS 422-485 or Current Loop line; 4÷16 TTL I/O lines; 3 Timers Counters; 64K EPROM; 64K RAM; 32K RAM backed; 32K DIL E2; 8K serial EEPROM; Watch dog; 1 readable DIP; LCD Interface; Abaco® I/O BUS; 5Vdc Power supply; Size: 100x50 mm.

GPC® 554

General Purpose Controller 80C552

Microprocessor 80C552 at 22 MHz; implementation completely CMOS; 32K EPROM; 32 K SRAM; 32 K EEPROM or SRAM; EEPROM; 2 RS 232 serial lines; 16 I/O TTL; 2 PWM lines; 16 bits Timer/Counter; Watch Dog; 6 signals A/D converter with resolution 10 bit; interface for **ABACO®** I/O BUS.

GPC® 154

“4” Type General Purpose Controller Z80

84C15 μ P, 10÷16 MHz; Full CMOS; 1 RS 232 line; 1 RS 232 or RS 422-485 line; 16 TTL I/O lines; 2÷4 Timers Counters; 512K EPROM or FLASH; 512K RAM and RTC backed; 8K serial EEPROM; Watch dog; 2 readable DIPs; LCD Interface; Abaco® I/O BUS; 5Vdc Pwer supply; Size: 100x50 mm.

GPC® 884

General Purpose Controller Am188ES

Microprocessor AMD Am188ES up to 40 MHz 16 bits; implementation completely CMOS; serie 4 format; 512K EPROM or FLASH; 512K SRAM backed with Lithium battery; RTC; 1 RS 232 serial line + 1 RS 232 or RS 422-485 or current loop; 16 I/O TTL; 3 timer/counter; watch dog; EEPROM; 11 signals A/D converter with 12 bit resolution; interface for **ABACO®** I/O BUS.

GPC® 114

General Purpose Controller 68HC11

Microprocessor 68HC11A1 at 8 MHz; implementation completely CMOS; serie 4 format; 32K EPROM; 32K SRAM backed with Lithium battery; 32K EPROM, SRAM, EEPROM; RTC; 1 serial line RS 232 or RS 422-485; 10 I/O TTL; 3 timer/counter; watch dog; 8 signals A/D converter with resolution 8 bit; 1 asynchronous serial line; extremely low power consumption; interface for **ABACO®** I/O BUS.

CAN 14

Control Area Network, 1 channel, galvanically insulated

UART CAN SJA1000; 1 serial channels galvanically insulated; **ABACO®** I/O BUS interface; 4 type dimension; support of CAN 2.0B protocol; transfer rate up to 1M bit/sec; direct mounting for DIN 247277-1 and 3 rails.

LAD 12

Low cost Analog to Digital conv. 12 bits

Dual slope 16 lines A/D converter; 12 bit + sign conversion; 12,5 conversions per second rate; range $\pm 2,048$ Vdc or 0÷20 mA; automatic running mode; 1 LED, 2 TTL input lines; 8 bit Bus; front panel.

LAD 15

Low cost Analog to Digital conv. 15 bits

Dual slope 16 lines A/D converter; 15 bit + sign conversion; 2,5 conversions per second rate; range $\pm 3,2768$ Vdc or 0÷20 mA; automatic running mode; 2 LEDs; 2 TTL input lines; 8 bit Bus; front panel.

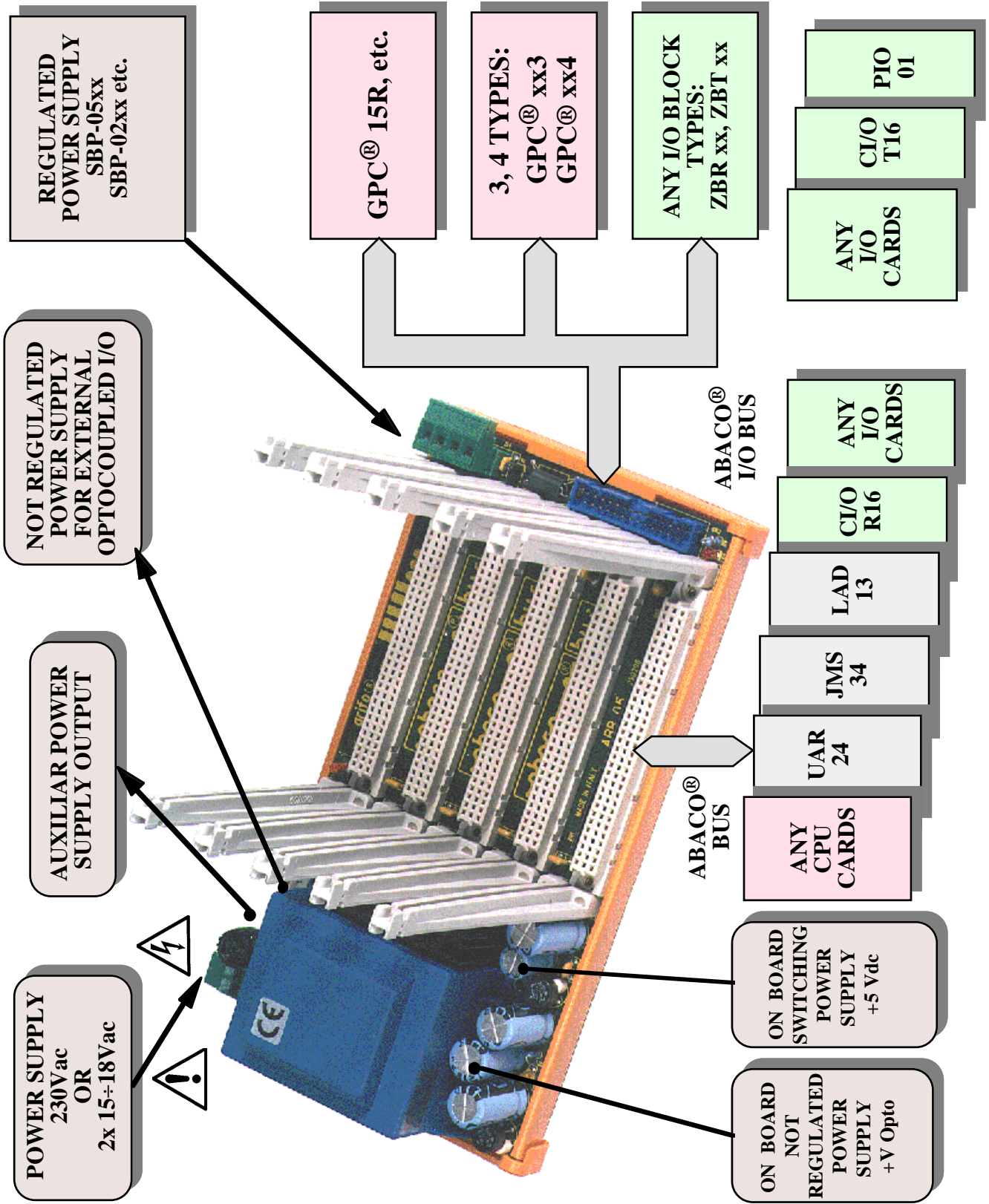

FIGURE 14: POSSIBLE CONNECTIONS DIAGRAM

NOTE

ABACO® BUS is not multimaster. Please remark that only one CPU intelligent control board can be installed in the ABACO® BUS and ABACO® I/O BUS chain.

LAD 415

4 Low cost Analog to Digital conv. 15 bits

4 independent A/D converter; 15 bit + sign conversion; 40 conversions per second rate; range $\pm 3,2768$, ± 5 , ± 10 Vdc; $4 \div 20$ mA; automatic running mode; 2 LEDs; 2 TTL input lines; 8 bit Bus.

DAC 16

Digital to Analog Converter 16 bits

2 Digital to Analog converter, 16 bits galvanically insulated; programmed data displayed; ± 10 Vdc output; gain and offset setting; 8 bit Bus; standard addressing.

ZBT xxx

Zipped BLOCK Transistors xy Input + yz Output

Peripheral cards family having xy optocoupled inputs and yz 3A open collector transistor outputs; plastic container for Ω rails mounting; double power supply, galvanically coupled, for the optocoupled input lines and for the logic plus external card. I/O lines displayed by LEDs; transistors outputs equipped with protection against inductive loads; I/O connections available on easy quick terminal connectors; interface to **ABACO**[®] I/O BUS. The following models are available: xxx=324 -> 32 In and 24 Out; xxx=246 -> 24 In and 16 Out; xxx=168 -> 16 In and 8 Out; xxx=84 -> 8 In and 4 Out.

BIBLIOGRAPHY

Here follows a list of manuals and technical notes that the User can read to acquire more informations about **ABB 05** mother board.

Manual SGS-THOMSON:

Industrial and Computer Peripheral ICs - Data Book

Please connect to the manufactures Web sites to get the latest version of all manuals and data sheets.



APPENDIX A: ALPHABETICAL INDEX

SYMBOLS**+5 VDC 6, 17****A****ABACO® 4, 10, 16, 17****B****BIBLIOGRAPHY 23****BOARD CONNECTIONS 16****C****CARD VERSION 1****CONNECTIONS 6****CONNECTORS 4****CN1 7****CN2 6****CN3 8****CN4 8****CN5 10****K1, K2, K3, K4, K5 12****E****ELECTRIC FEATURES 5****EXTERNAL CARDS 18****F****FUSE 5****G****GENERAL INFORMATION 2****I****INSTALLATION 6****INTRODUCTION 1****J****JUMPER 14**

L

LEDS 14

LOW VOLTAGE 5, 7

LOW VOLTAGE POWER SUPPLY 17

M

MAINS 5, 7

MAINS POWER SUPPLY 17

P

PHYSICAL FEATURES 4

POWER SUPPLY 6, 17

R

RELATIVE HUMIDITY 4

RESET KEY 16

S

SIZE 4

SLOTS PITCH 4

SUPPLY VOLTAGES SELECTION 17

T

TECHNICAL FEATURES 4

TEMPERATURE RANGE 4

TERMINATION RESISTORS 16

TTL 16

V

V OPTO 6, 8, 17

VISUAL SIGNALATIONS 14

W

WEIGHT 4