

ADC 812

Analog to Digital Converter - 8 channels 12 bit

TECHNICAL MANUAL

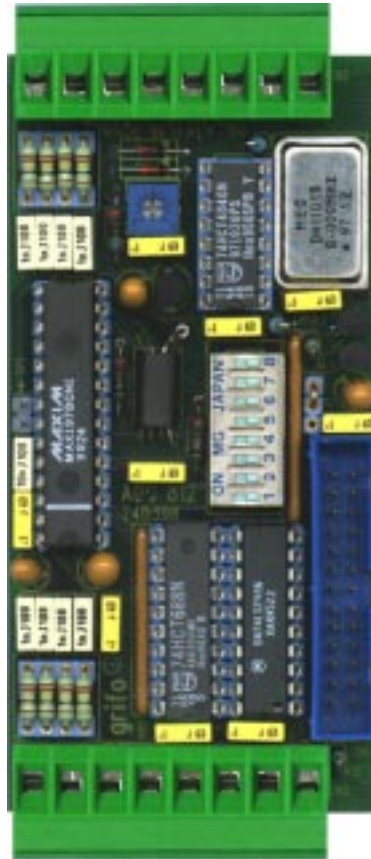

grifo[®]
ITALIAN TECHNOLOGY

Via dell' Artigiano, 8/6
40016 San Giorgio di Piano
(Bologna) ITALY
E-mail: grifo@grifo.it



<http://www.grifo.it> <http://www.grifo.com>
Tel. +39 051 892.052 (a. r.) FAX: +39 051 893.661

ADC 812

Rel. 5.00

Rel. 18 June 2002

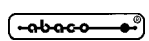
, GPC[®], grifo[®], are trade marks of grifo[®]

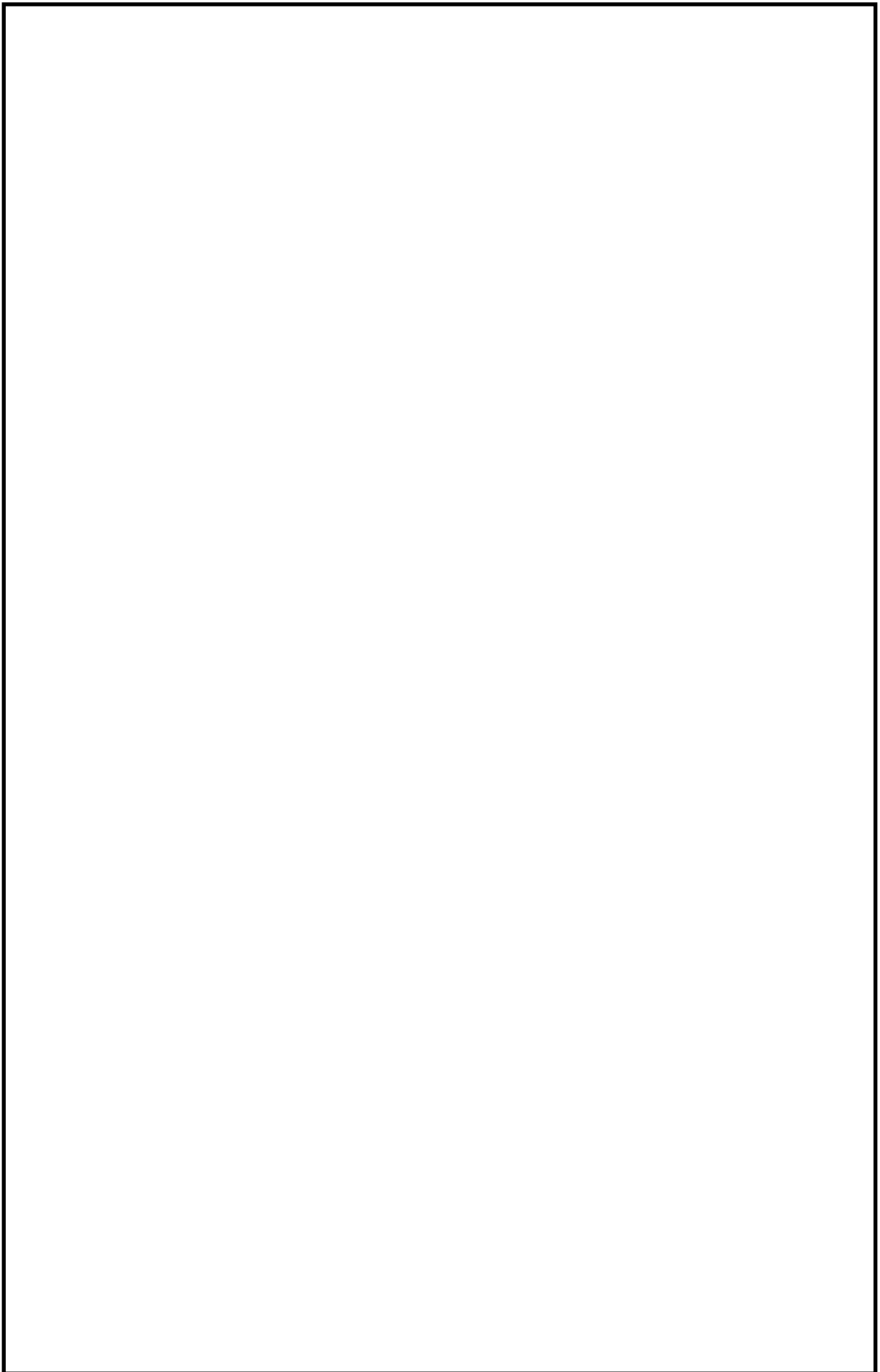

ADC 812

Analog to Digital Converter - 8 channels 12 bit

TECHNICAL MANUAL

Interface for **Abaco® I/O BUS** on **26 pins** standard low profile connector; dimension: **100x50x30** mm, (110x60x70 mm with container) in **4 type** format; optional plastic support for **DIN 46277-1** and **DIN 46277-3** Ω rails; one **A/D Converter** section, 8 channels, **12 bits**, based on **DAS MAX197**; **9 μ s** conversion time, for each channel; 5Mhz Bandwidth **Track Hold**, 100Ksps Sampling-Rate; software controlled indication of **polarity**; input range and input channel selectable by software; available input ranges: **$\pm 10V$, $\pm 5V$, $+10V$, $+5V$** or **$0 \div 20mA$, $4 \div 20mA$** with optional conversion module: **.8420**; **fault protected** input multiplexer ($\pm 16,5V$); **two 8 pins quick release screw terminal** connectors, for all analog inputs; **interrupt** request joined to end of conversion; interrupt connection to **/INT** or **/NMI**, selectable by hardware; only **2** consecutives Bytes used for card **I/O** addressing; card **I/O** allocation address defined through proper **dip switch**; single power supply voltage: **+5 Vdc**; **80 mA**.

grifo®
ITALIAN TECHNOLOGY

Via dell' Artigiano, 8/6
40016 San Giorgio di Piano
(Bologna) ITALY
E-mail: grifo@grifo.it



<http://www.grifo.it> <http://www.grifo.com>
Tel. +39 051 892.052 (a. r.) FAX: +39 051 893.661

ADC 812

Rel. 5.00

Rel. 18 June 2002

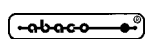
 **GPC®**, **grifo®**, are trade marks of **grifo®**

DOCUMENTATION COPYRIGHT BY grifo®, ALL RIGHTS RESERVED

No part of this document may be reproduced, transmitted, transcribed, stored in a retrieval system, or translated into any language or computer language, in any form or by any means, either electronic, mechanical, magnetic, optical, chemical, manual, or otherwise, without the prior written consent of **grifo®**.

IMPORTANT

Although all the information contained herein have been carefully verified, **grifo®** assumes no responsibility for errors that might appear in this document, or for damage to things or persons resulting from technical errors, omission and improper use of this manual and of the related software and hardware.

grifo® reserves the right to change the contents and form of this document, as well as the features and specification of its products at any time, without prior notice, to obtain always the best product.

For specific informations on the components mounted on the card, please refer to the Data Book of the builder or second sources.

SYMBOLS DESCRIPTION

In the manual could appear the following symbols:



Attention: Generic danger



Attention: High voltage

Trade Marks

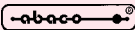
, **GPC®**, **grifo®** : are trade marks of **grifo®**.

Other Product and Company names listed, are trade marks of their respective companies.

GENERAL INDEX

INTRODUCTION	1
CARD VERSION	1
GENERAL INFORMATIONS	2
A/D CONVERTER	4
INPUT FILTERS	4
REFERENCE VOLTAGE	6
INTERFACING AND ADDRESSING	6
TECHNICAL FEATURES	7
GENERAL FEATURES	7
PHYSICAL FEATURES	7
ELECTRIC FEATURES	7
INSTALLATION	8
TRIMMERS AND CALIBRATION	8
TEST POINT	8
CONNECTIONS	10
CN2 - A/D CONVERTER INPUTS 0÷3 CONNECTOR	10
CN3 - A/D CONVERTER INPUTS 4÷7 CONNECTOR	12
CN1 - ABACO® I/O BUS CONNECTOR	13
I/O CONNECTION	14
TYPE OF ANALOG INPUT SELECTION	14
JUMPERS	15
POWER SUPPLY SELECTION	15
MECHANICAL MOUNTING	16
INTERRUPT	16
ADDRESSES AND MAPS	17
BOARD MAPPING	17
I/O ADDRESSES	18
PERIPHERAL DEVICES SOFTWARE DESCRIPTION	19
A/D CONVERTER	19
INITIALIZATION SEQUENCE	22
POLLING CONVERSION	22
INTERRUPT CONVERSION	22
EXTERNAL CARDS	23
BIBLIOGRAPHY	27
APPENDIX A: ALPHABETICAL INDEX	A-1

FIGURES INDEX

FIGURE 1: CARD PHOTO	3
FIGURE 2: COMPONENTS MAP	3
FIGURE 3: BLOCK DIAGRAM	5
FIGURE 4: TEST POINT FOR REFERENCE VOLTAGE	8
FIGURE 5: CONNECTORS, TEST POINT, DIP SWITCH, ETC. LOCATION	9
FIGURE 6: A/D CONVERTER INPUTS 0÷3 CONNECTOR	10
FIGURE 7: ANALOG INPUT BLOCK DIAGRAM	11
FIGURE 8: A/D CONVERTER INPUTS 0÷3 CONNECTOR	12
FIGURE 9: CN1 - ABACO® I/O BUS CONNECTOR	13
FIGURE 10: JUMPER SUMMARIZING TABLE	15
FIGURE 11: INTERNAL REGISTERS ADDRESSES TABLE	18
FIGURE 12: POSSIBLE CONNECTIONS DIAGRAM	25



INTRODUCTION

The use of these devices has turned - IN EXCLUSIVE WAY - to specialized personnel.

The purpose of this handbook is to give the necessary information to the cognizant and sure use of the products. They are the result of a continual and systematic elaboration of data and technical tests saved and validated from the manufacturer, related to the inside modes of certainty and quality of the information.

The reported data are destined- IN EXCLUSIVE WAY- to specialized users, that can interact with the devices in safety conditions for the persons, for the machine and for the enviroment, impersonating an elementary diagnostic of breakdowns and of malfunction conditions by performing simple functional verify operations , in the height respect of the actual safety and health norms.

The informations for the installation, the assemblage, the dismantlement, the handling, the adjustment, the reparation and the contingent accessories, devices etc. installation are destined - and then executable - always and in exclusive way from specialized warned and educated personnel, or directly from the TECHNICAL AUTHORIZED ASSISTANCE, in the height respect of the manufacturer recommendations and the actual safety and health norms.

The devices can't be used outside a box. The user must always insert the cards in a container that respect the actual safety normative. The protection of this container is not threshold to the only atmospheric agents, but specially to mechanic, electric, magnetic, etc. ones.

To be on good terms with the products, is necessary guarantee legibility and conservation of the manual, also for future references. In case of deterioration or more easily for technical updates, consult the AUTHORIZED TECHNICAL ASSISTANCE directly.

To prevent problems during card utilization, it is a good practice to read carefully all the informations of this manual. After this reading, the user can use the general index and the alphabetical index, respectly at the begining and at the end of the manual, to find information in a faster and more easy way.

CARD VERSION

The present handbook is reported to the **ADC 812** card release **240398** and later. The validity of the bring informations is subordinate to the number of the card release. The user must always verify the correct correspondence among the two denotations. On the card the release number is present in more points both board printed diagram (serigraph) and printed circuit (for example near capacitor C16 both on the component sideand on the solder side).

GENERAL INFORMATION

The **ADC 812** is a powerful peripheral, high speed, low price, analog to digital converter card, included in **Abaco®** industrial family. It is composed by a 12 bits A/D converter section, based on the **multi range MAX197 DAS** (Data Acquisition System) and it provides 8 independent analog inputs.

The electric connection of the card is performed through three comfortable connectors: one for the control cards with **Abaco® I/O BUS**, and the other two for the input analog signals; the mechanical mounting is simplified by a proper optional plastic support for **DIN 46277-1** and **DIN 46277-3** omega rails.

The **ADC 812** card is the right component for all the applications where it is required a low price, an high number of signals to be acquired and an high conversion speed. If the number of required analog input channels is higher than those available on the board, it is more suitable an europe card size with **Abaco® BUS**.

A very important feature of **ADC 812** are the **multi range** analog inputs, in fact with a simple software setting, many different input signals can be converted; furthermore, there are two handy sockets 8 way each, where you can mount up to 8 precision resistors to quickly specialize, each one of the eight voltage inputs, into current inputs in the range **0÷20mA** or **4÷20mA**.

A wide range of demo programs and examples allow an immediate use of the same. These programs are available for the whole CPUs of **Abaco®** family. They are duly documented and supplied under source form for many different languages in which **Abaco®** control cards can be programmed.

- Interface for **Abaco® I/O BUS** on **26 pins** standard low profile connector.
- Dimension: **100x50x40** mm, (110x60x70 mm with container) in **4 type** format.
- Optional plastic support for **DIN 46277-1** and **DIN 46277-3** Ω rails.
- One **A/D Converter** section, 8 channels, **12 bits**, based on **DAS MAX197**.
- **9 μ s** conversion time, for each channel.
- 5Mhz Bandwidth **Track Hold**, 100Ksps Sampling-Rate.
- Software controlled indication of **polarity**.
- Input range and input channel selectable by software.
- Available input ranges: **$\pm 10V$, $\pm 5V$, $+10V$, $+5V$** or **0÷20mA, 4÷20mA** with optional conversion module: **.8420**.
- **Fault protected** input multiplexer ($\pm 16.5V$)
- **Two 8 pins quick release screw terminal** connectors, for all analog inputs.
- **Interrupt** request joined to end of conversion.
- Interrupt connection to **/INT** or **/NMI**, selectable by hardware.
- Only **2** consecutives Bytes used for card **I/O** addressing.
- Card **I/O** allocation address defined through proper **dip switch**.
- Single power supply voltage: **+5 Vdc; 80 mA**.

Here follows a description of the board's functional blocks, with an indication of the operations performed by each one. To easily locate these blocks and verify their connections please refer to figure 3.

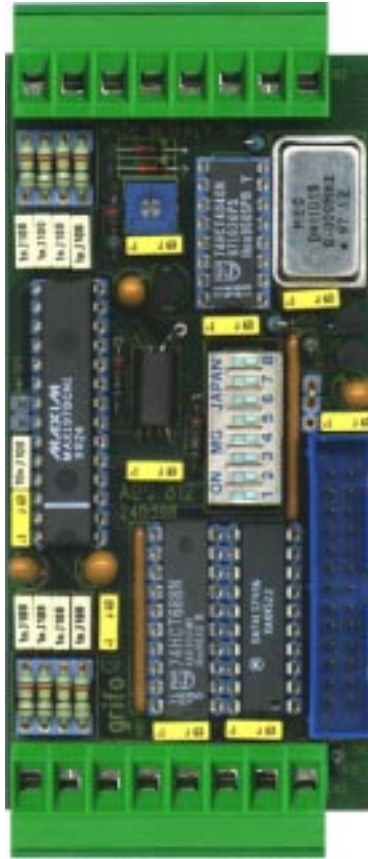

FIGURE 1: CARD PHOTO

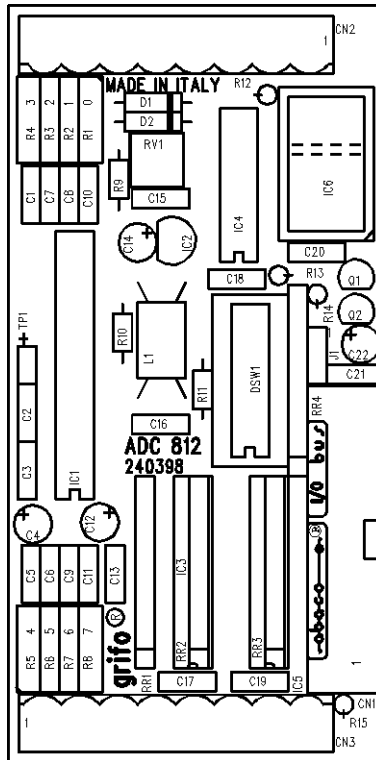

FIGURE 2: COMPONENTS MAP

A/D CONVERTER

DAC 812 performs the eight channels A/D conversion by a MAX 197, that is a multi-range, 12-bit data-acquisition system (DAS) which uses successive approximation and internal track/hold circuitry.

Main features of this device are:

- Resolution 12 bits in unipolar mode or 11 bits plus sign in bipolar mode.
- Multi-range software configurable inputs, allowed ranges are 0÷5 V, 0÷10 V, ±5 V, ±10 V.
- Conversion time per channel 6 µsec.
- Maximum linearity error ±1 LSB.
- Fault Protected Input Multiplexer (±16.5 V).
- 5 MHz Bandwidth Track Hold, sample rate per channel 100 Ksps independent for each section.
- easy software management; end-of-conversion interrupt generation.

MAX 917 is the ideal component for common applications in industrial automation, where both conversion speed and resolution must be high. For further information please refer to manufacturers information.

INPUT FILTERS

The eighth analog inputs of **ADC 812** are provided with a filtering circuitry that decrease sensibility to field noises. These sections are based on high precision components and are set up in laboratory, to deliver cards with the same interfacement.

The filters are made to install an optional module for current-to-voltage conversion which is based on 248 Ω selected precision resistors that allow to acquire signals in the range 0÷20 mA or 4÷20 mA. For further information please refer to figure 7.

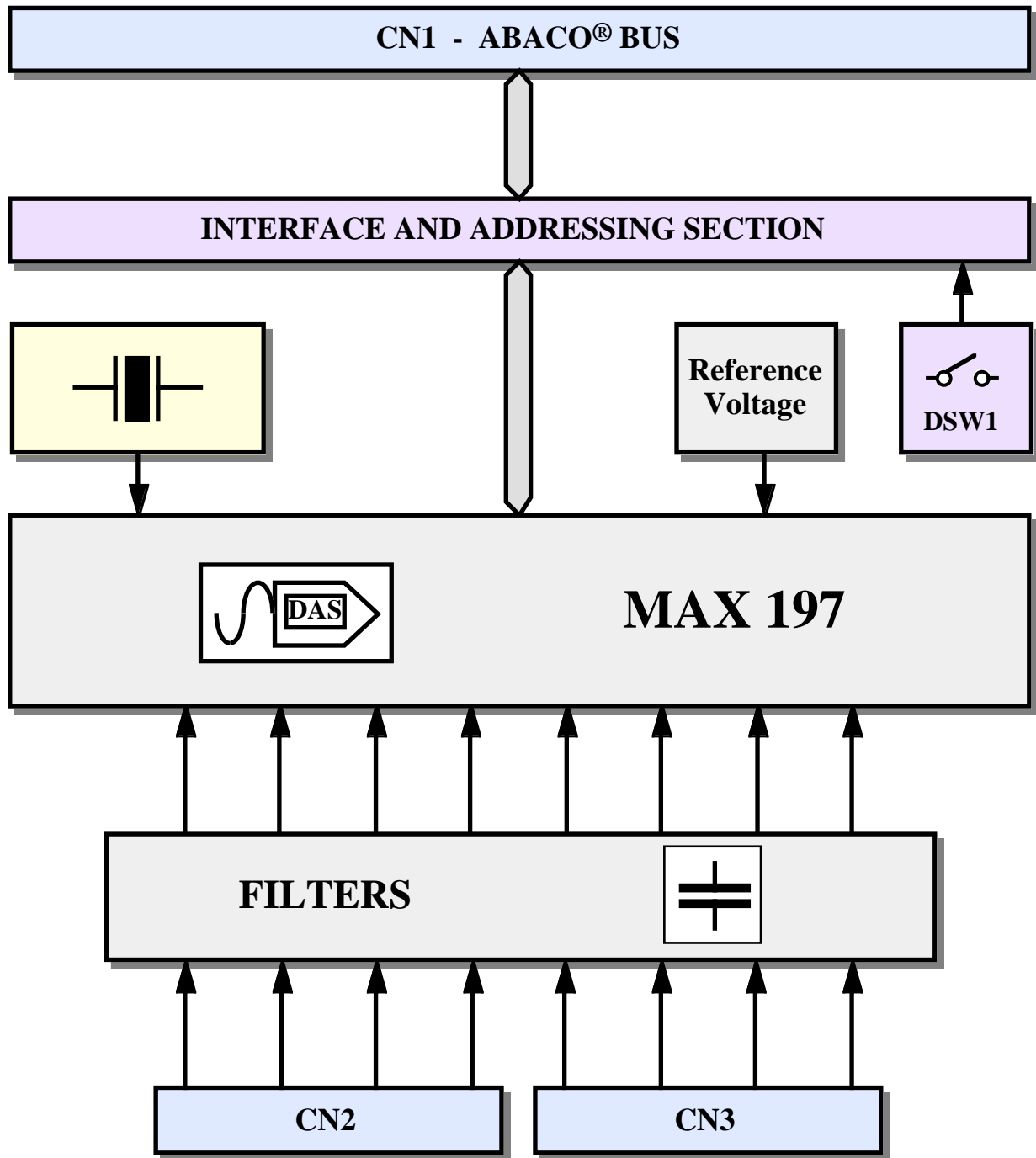

FIGURE 3: BLOCK DIAGRAM

REFERENCE VOLTAGE

A precision circuitry is charged to generate the reference voltage required by the A/D converter section. This circuitry is designed to provide a tension stabilized and independent from **ADC 812** on board power supply and temperature changes, obtaining a greater precision.

This tension is calibrated in test phase and the user must not change it. For further information please refer to paragraph “TRIMMER ADN CALIBRATIONS”.

INTERFACING AND ADDRESSING

This section manages the data exchange between CAN controller and command board; in particular, all written or read data transit across this section that, in addition, provides the board I/O management in its addressing space and an eventual interrupt generation by setting the dip switch **DSW1**.

Physical connection to command boards is performed through **ABACO®** I/O BUS, featuring 8 data bits, but it can be extended to **ABACO®** BUS using specific conversion modules like **ABB 05** or **ABB 03**.

Interfacing and addressing section is based on logic gates and buffers carefully selected to warrant a correct working under any condition and minimize the room taken.

TECHNICAL FEATURES

GENERAL FEATURES

BUS:	ABACO® I/O BUS	
Analog signals:	8	
Addressing space:	256 bytes	
Bytes taken:	2	
On board resources:	DAS MAX 197	
Oscillator frequency:	8 MHz	
Work frequency:	2 MHz	
Conversion time:	9 µsec per channel	
A/D Resolution:	12 bit	(Unipolar mode)
	11 bit + sign	(Bipolar mode)
Linearity maximum error:	±1 LSB	(*)
Offset maximum error:	±1 LSB	(*)
Differential input error:	±1 LSB	(*)
Connectors:	CN1: 26 pins low profile vertical male CN2: 8 pins quick release screw terminal CN3: 8 pins quick release screw terminal	

PHYSICAL FEATURES

Size:	100 x 50 x 30 mm	(without container)
	110 x 60 x 65 mm	(with DIN container)
Weight:	85 g	
Temperature range:	0÷50 °C	
Relative humidity:	20%÷90%	(without condense)

ELECTRIC FEATURES

Power supply voltage:	+5 Vdc	
Consumption on +5 Vdc:	80 mA	
Input impedance:	21 kΩ	(unipolar mode)
	16 kΩ	(bipolar mode)
Cut off frequency:	1 MHz	

* Data here reported are referred to a 20 centigrad degrees environmental temperature

INSTALLATION

In this chapter there are the information for a right installation and correct use of the card. The user can find the location and functions of each connectors, dip switch, LEDs, etc. and some explanatory diagrams.

TRIMMER AND CALIBRATION

On **ADC 812** there is available a trimmer, named **RV1**, that calibrates the Vref voltage of the optional A/D converter section. The **ADC 812** is subjected to a careful test that verifies and calibrates all the card sections. To easily locate the trimmer, please refer to figure 5. The calibration is executed in laboratory, with a controlled +20 C° room temperature, following these steps:

- The A/D voltage reference (Vref) is calibrated through RV1 trimmer, by using a 5 digits precision multimeter, to a value of +4,096 Vdc, measured on test point TP1.
- The corrispondance between the analog input signal and the combination read from A/D is verified. This check is performed with a reference signal connected to A/D inputs and testing that the A/D combination and the theoric combination differ at maximum of the A/D section errors sum.
- The trimmer is blocked with paint.

The analog interfaces use high precision components that are selected during mounting phase to avoid complicate and long calibration procedures. After the calibration, the on board trimmer is blocked with paint to mantain calibration also in presence of mechanic stresses (vibrations, movings, delivery, etc.).

The user must not modify the card calibration, but if thermic drifts,time drifts and so on, make necessary a new calibration, the user must strictly follow the previous described procedure.

TEST POINT

The board is provided with a test point called TP1, that allows to read, through a galvanically isolated multimeter, the A/D converter reference voltage which is calibrated in laboratory.

TP1 is made of two contacts:

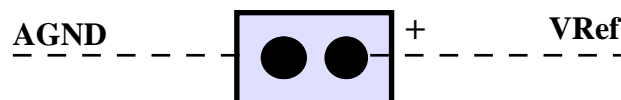

FIGURE 4: TEST POINT FOR REFERENCE VOLTAGE

VRef	->	4.096 Vdc reference voltage
AGND	->	Analog ground signal

To easily locate the test point contacts please refer to figure 5, while for further informations about Vref signal please refer to the paragraph “TRIMMER AND CALIBRATION”.

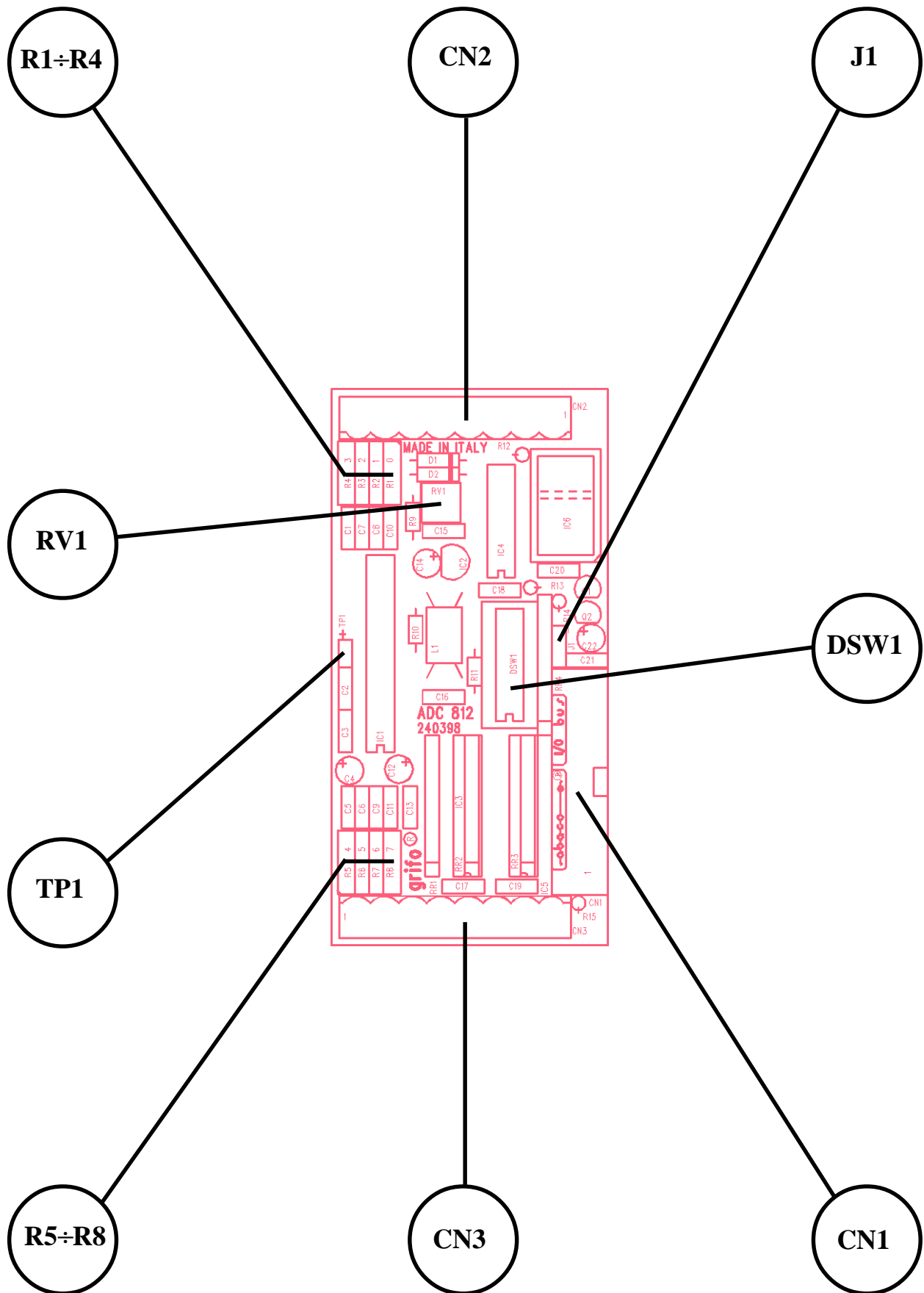

FIGURE 5: CONNECTORS, TEST POINT, DIP SWITCH, ETC. LOCATION

CONNECTIONS

The ADC 812 module has 3 connectors that can be linkeded to other devices or directly to the field, according to system requirements. In this paragraph there are connectors pin out, a short signals description (including the signals direction), connectors location (please refer to figure 5) and some electrical diagrams that shows the on board circuit of each connector.

CN2 - A/D CONVERTER INPUTS 0÷3 CONNECTOR

CN2 is a 8 pins, quick release screw terminal connector.

Through CN2 the first 4 A/D converter section input signals interface to the external world, in detail inputs from 0 to 3 of A/D converter section are available.

Analog lines are provided with a low-pass filter and are placed in order to reduce interference and electrical noise warranting a good signal transmission and in order to simplify connection with other systems.

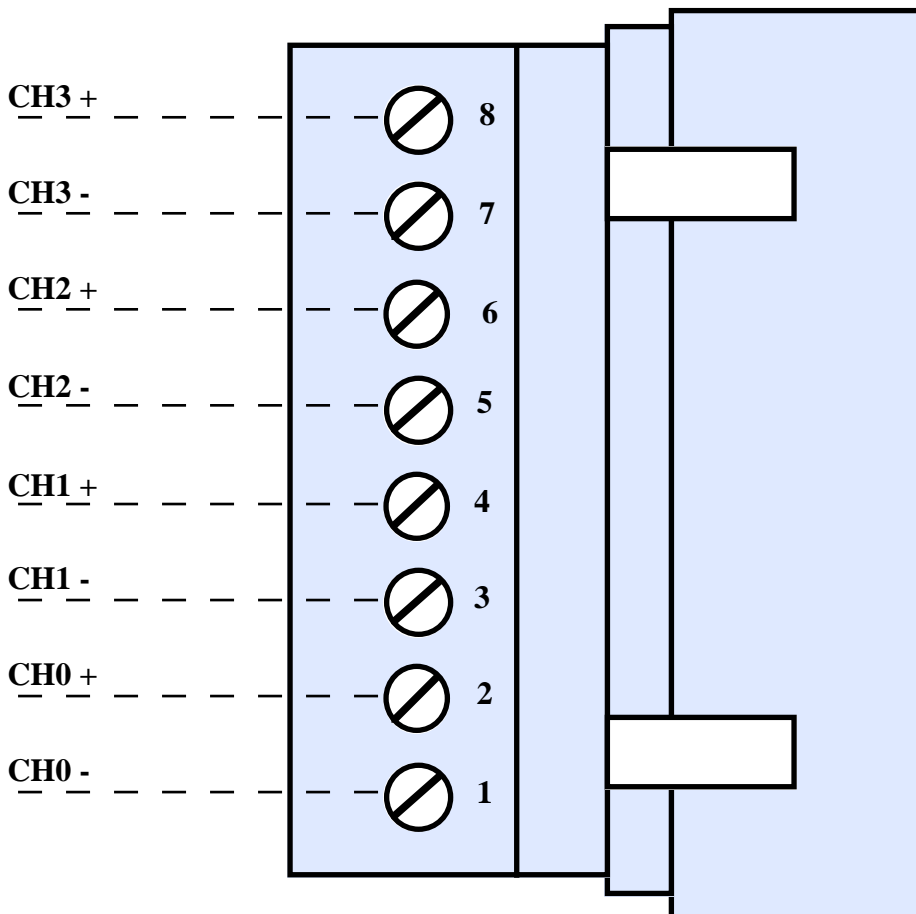

FIGURE 6: A/D CONVERTER INPUTS 0÷3 CONNECTOR

Signals description:

- CHn+ = I - n-th analog input.
- CHn- = I - n-th analog input ground.

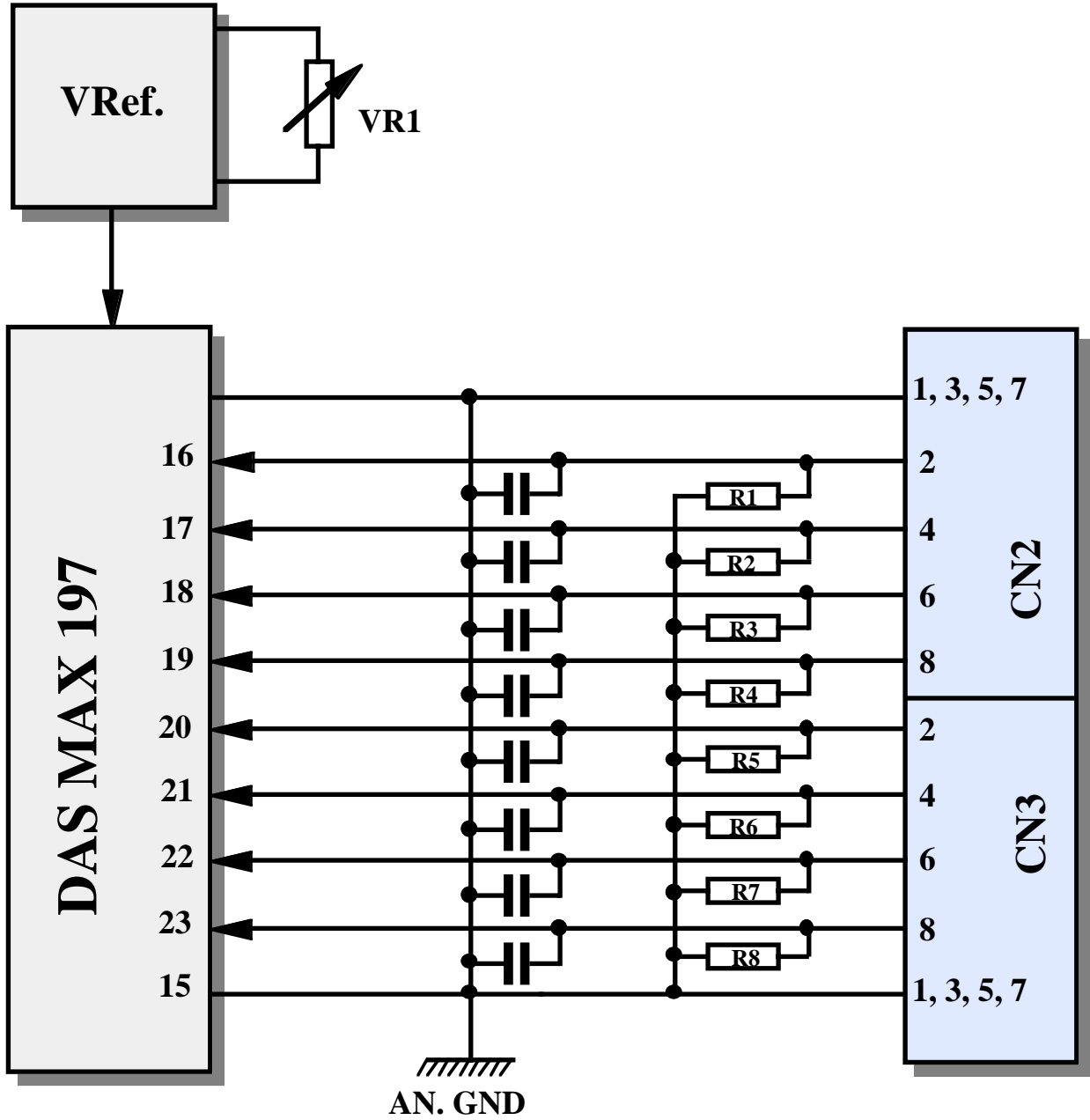

FIGURE 7: ANALOG INPUT BLOCK DIAGRAM

CN3 - A/D CONVERTER INPUTS 4÷7 CONNECTOR

CN3 is a 8 pins, quick release screw terminal connector.

Through CN3 the second 4 A/D converter section input signals interface to the external world, in detail inputs from 4 to 7 of A/D converter section are available.

Analog lines are provided with a low-pass filter and are placed in order to reduce interference and electricale nois warranting a good signal transmission and in order to simplify connection with other systems.

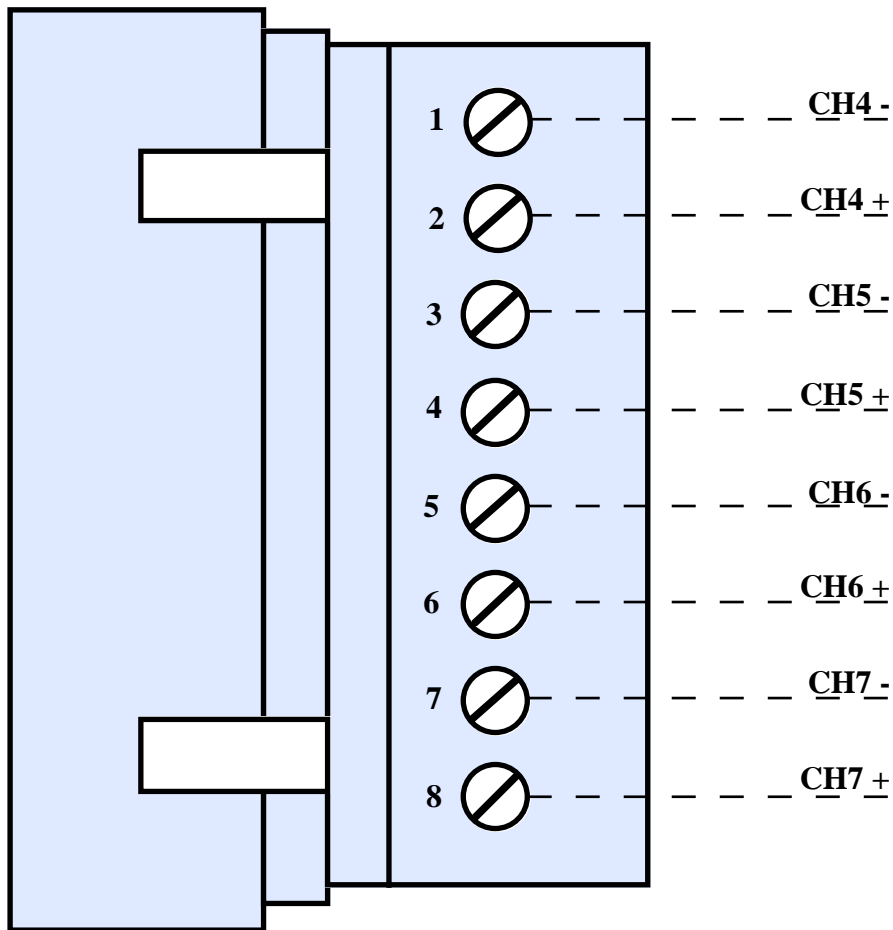

FIGURE 8: A/D CONVERTER INPUTS 0÷3 CONNECTOR

Signals description:

- CHn+ = I - n-th analog input.
- CHn- = I - n-th analog input ground.

CN1 - ABACO® I/O BUS CONNECTOR

CN1 is a 26 pins, male, vertical, low profile connector with 2.54 mm pitch.

Through CN1 the card can be connected via **ABACO®** I/O BUS to some of the numerous **grifo®** boards, both intelligent and not. For example the user can directly use cards for analog signals acquisition (A/D), cards for analog signals generation (D/A), cards for digital I/O signals management, cards with timers and counters, etc. All this connector signals are at TTL level.

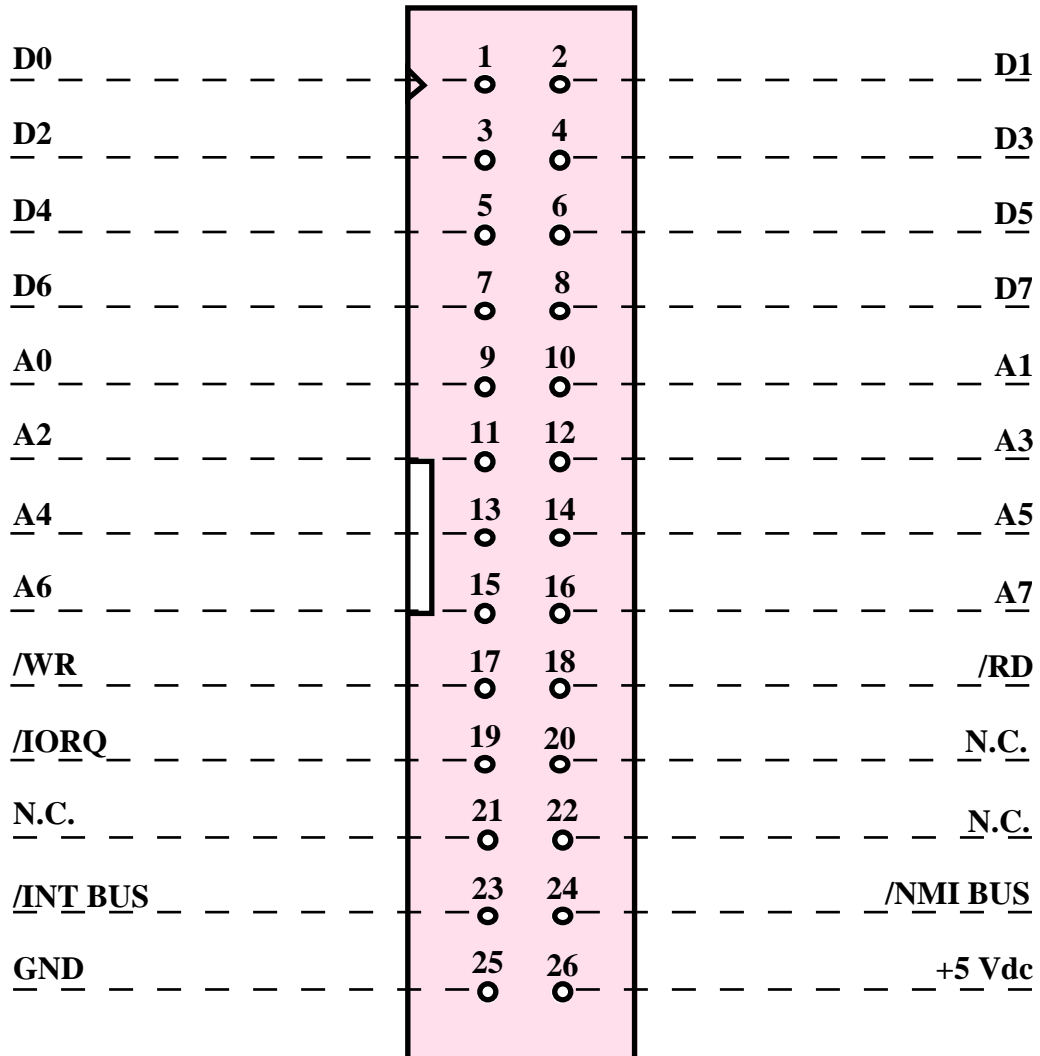

FIGURE 9: CN1 - ABACO® I/O BUS CONNECTOR

Signals description:

- A0÷A7** = O - Address BUS.
- D0÷D7** = I/O - Data BUS.
- /INT BUS** = I - Interrupt request (open collector type).
- /NMIBUS** = I - Non mascable interrupt.
- /IORQ** = O - Input output request.
- /RD** = O - Read cycle status.
- /WR** = O - Write cycle status.
- /RESET** = O - Reset.
- +5 Vdc** = I - +5 Vdc power supply.
- GND** = - Ground signal.
- N.C.** = - Not connected.

I/O CONNECTION

To prevent possible connecting problems between **GPC® 153** and the external systems, the user has to read carefully the information of the previous paragraphs and he must follow these instructions:

- For all TTL signals the user must follow the rules of this electric standard. The connected digital signal must be always referred to card digital ground (GND). For TTL signals, the 0 Vdc level corresponds to logic state "0", while 5Vdc level corresponds to logic state "1". For **ABACO®** I/O BUS signals it is suggested to use connection of at most 10 centimeters.
- The analog inputs (A/D section) must be connected to low impedance signals in the selected voltage range (please refer to paragraph "SOFTWARE DESCRIPTION"). Remember that the eight analog inputs available on CN2 and CN3 are provided of filter capacitors that ensure an higher stability of the acquired signals, but reduce at the same time the bandwidth frequency.

TYPE OF ANALOG INPUT SELECTION

ADC 812 board can accept analog voltage and/or current inputs, as described in the previous paragraphs and chapters. The input type selection must be made during the order phase and is performed mounting a specific voltage-current conversion module (option code **.8420**) made by precision resistors. In detail:

R1	->	channel 0
R2	->	channel 1
R3	->	channel 2
R4	->	channel 3
R5	->	channel 4
R6	->	channel 5
R7	->	channel 6
R8	->	channel 7

Should the voltage-current conversion module not to be mounted (default case) the corresponding channel accepts a voltage input signal in the ranges 0÷5 V, 0÷10 V, ±5 V or ±10 V; otherwise a current input signal is accepted.

In this latter case the input range must be set as 0÷5 V, so the value of the above mentioned resistors is obtained by the following spread;

$$R = 5 V / I_{max}$$

Usually the voltage-current conversion modules are made using 248 Ω precision resistors, corresponding to 4÷20 mA or 0÷20 mA.

Any eventual configuration out of this standard should be asked directly to **grifo®**.

To easily locate the voltage-current conversion module please refer to figure 5.

JUMPERS

On **ADC 812** there is 1 jumper for card configuration. Connecting this jumper, the user can define the board devices functionality.

JUMPER	CONNECTION	PURPOSE	DEF.
J1	not connected	Interrupt of A/D converter section not connected to ABACO ® I/O BUS.	*
	position 1-2	Interrupt of A/D converter section connected to /INT signal on ABACO ® I/O BUS.	
	position 2-3	Interrupt of A/D converter section connected to /NMI signal on ABACO ® I/O BUS.	

FIGURE 10: JUMPER SUMMARIZING TABLE

To recognize the valid connections, please refer to the board printed diagram (serigraph) or to figure 2 of this manual, where the pins numeration is listed; for recognizing jumpers location, please refer to figure 5.

The "*" used in the following tables, denotes the default connection, or on the other hand the connection set up at the end of testing phase, that is the configuration the User receives.

POWER SUPPLY SELECTION

ADC 812 board is provided with an efficient circuitry that solves in an efficient and comfortable way the problem of power supply in any employ condition. Here follow the needed voltage for its working:

+ 5Vdc: Power supply to all the sections of the card; it must be +5 Vdc $\pm 5\%$ and must be provided through the specific pins of connector CN1 (**ABACO**® I/O BUS).

The board features a circuitry charged to generate all the voltages needed by its sections starting from the unique +5 Vdc supply.

Please remark that in previous paragraphs the AGND indication is used to indicate the analog reference. Such signal is physically connected to power supply reference through a star-connection, to reduce noise and interferences.

MECHANICAL MOUNTING

By default, **ADC 812** board is provided without any container, but optionally are available items that easy remarkably its mechanical mounting. These items are plastic container designed to be installed on Ω rails type **DIN 46277-1** and **DIN 46277-3**, like, for example, item **BLOCK.100.50**. Should the **ADC 812** be matched to other boards provided with **ABACO®** I/O BUS, it is possible to order an unique container for all the boards, to simplify the mounting and reduce the costs. For further information please call **grifo®** directly.

INTERRUPT

ADC 812 is provided with a comfortable and efficient interrupt generation circuitry, that, if enabled, can generate an interrupt to the **GPC®** control card when conversion ends. Such circuitry allows to optimize the time needed to manage the board, in fact the **GPC®** intelligent control card is not obliged to poll **ADC 812** registers, but can simply wait for an interrupt and manage the new data interchange. **ABACO®** I/O BUS interrupt signal remains activated until the control card accesses **ADC 812** to read the conversion value. This warrants a correct management also in case of multiple interrupt because the interrupt is disengaged only by an appropriate software management, which is time independent. Please remark that interrupt generation circuitry can be connected or not connected to **ABACO®** I/O BUS through the specific jumper J1 as described in the paragraph “JUMPER”.

ADDRESSES AND MAPS

In this chapter are reported all information about card use, related to hardware and software. For example, the registers addresses and the memory allocation are described below.

BOARD MAPPING

ADC 812 board is mapped into a **2** bytes I/O addressing space, that can be allocated starting from different base addresses according to how the board is configured. This feature allows to use several **ADC 812** cards on the same **ABACO® I/O BUS** or **ABACO® BUS**, or to install them on a **BUS** where other peripheral modules are installed obtaining a structure that can be expanded without any difficulty or modifications to the application software. These bytes allow the complete control of board settings and status and the complete flow of input and output data.

The base address can be defined through the specific **BUS** interface circuitry on the board itself; this circuitry uses the eight pins dip switch called **DSW1**, from which it reads the address set by the user. Here follows the corrispondance between dips configuration and address signals, to easily locate such component please refer to figure 5.

DSW1.1	->	Not used
DSW1.2	->	Bit A1
DSW1.3	->	Bit A2
DSW1.4	->	Bit A3
DSW1.5	->	Bit A4
DSW1.6	->	Bit A5
DSW1.7	->	Bit A6
DSW1.8	->	Bit A7

These dips are driven in complemented logic, this means that if a switch is **ON** generates a **logic zero**, viceversa if a switch is **OFF** generates a **logic one**.

NOTE

When allocating the mapping address of the boards, please be careful not to allocate more than one device in the same addressing space (count also the number of bytes occupied by the card). If this condition will not be respected, a **BUS** conflict will happen; such conflict will compromise the correct working of the whole system.

As an example, dip configuration to set address 048H is reported here:

DSW1.1	->	Indifferent
DSW1.2	->	ON
DSW1.3	->	ON
DSW1.4	->	OFF
DSW1.5	->	ON
DSW1.6	->	ON
DSW1.7	->	OFF
DSW1.8	->	ON

I/O ADDRESSES

The on board control logic manages the allocation of all the peripheral devices registers in the microprocessor I/O space, that is 256 bytes long.

Indication <baseadd> means the base address of the board decided with DSW1, as previously described.

DEV.	REG.	ADDRESS	R/W	PURPOSE
MAX 197	DASCTRL	<baseadd>+00	W	Control register of A/D section based on DAS MAX 197.
	DASL	<baseadd>+00	R	Data register (bit 7÷0) of A/D section based on DAS MAX 197.
	DASH	<baseadd>+01	R	Data register (bit 11÷8) of A/D section based on DAS MAX 197.

FIGURE 11: INTERNAL REGISTERS ADDRESSES TABLE

Table of figure 11 shows names, addresses, meanings and directions of peripheral device registers. For further information please refer to chapter “PERIPHERAL DEVICES SOFTWARE DESCRIPTION”.

PERIPHERAL DEVICES SOFTWARE DESCRIPTION

In the previous paragraphs are described the external registers addresses, while in this one there is a specific description of registers meaning and function (please refer to I/O addresses table, for the registers names and addresses values). For a more detailed description of the devices, please refer to manufacturing company documentation. In the following paragraphs the **D7÷D0** and **.0÷7** indications denote the eight bits of a register.

A/D CONVERTER

A/D converter section installed on **ADC 812** is based on DAS MAX 197. This device is managed through three registers, two readable and one writable as shown in figure 11, such registers are called DASCTRL, DASL and DASH, they allow the user to perform all the operations proper of this section.

Here follows the meaning of the registers and their use.

Register DASCTRL

This write register manages the DAS MAX 197 operations: a write instruction to its address will start the conversion from the specified channell in the specified range.

The meaning of the bits register is:

D7	->	PD1
D6	->	PD0
D5	->	ACQMOD
D4	->	RNG
D3	->	BIP
D2	->	A2
D1	->	A1
D0	->	A0

PD1 PD0	= Set the working modality of A/D converter amongst the following:
0 0	-> Use external clock in normal mode
0 1	-> Use internal clock in normal mode (<u>DO NOT USE</u>)
1 0	-> Standby Power-Down mode
1 1	-> Full Power-Down mode

NOTE

Never use internal clock in normal mode, because **ADC 812** employs its own clock circuitry designed to optimize conversion time and noise immunity.

ACQMOD = Controls the A/D internal Track-Hold working:

0	-> Track-Hold of the channel specified by A0÷A2, remains active for 3 µsec then begins the conversion phase of the signal captured.
1	-> Track-Hold of the channel specified by A0÷A2, is activated and remains active up to the next write to the control register, the data written will be equal to the previous one, but ACQMOD=0. By this modality the User can capture the signal to be converted for as long as he/she wishes.

RNG BIP = Set the voltage range for the analog channel, specified by bit A0÷A2; this setting will affect only the conversion the device is going to perform, so it may vary from channel to channel and even on the same channel for different conversions:

RNG BIP

0	0	-> Range 0÷5 V
1	0	-> Range 0÷10 V
0	1	-> Range ±5 V
1	1	-> Range ±10 V

A2 A1 A0 = Select the analog input channel where the Track-Hold operation and the next conversion of the signal captured will be performed:

A2	A1	A0	
0	0	0	-> Channel 0
0	0	1	-> Channel 1
0	1	0	-> Channel 2
0	1	1	-> Channel 3
1	0	0	-> Channel 4
1	0	1	-> Channel 5
1	1	0	-> Channel 6
1	1	1	-> Channel 7

EXAMPLE

For example, writing 0BH into register ADCNT, the device will perform a conversion from line ADC3 connected to connector CN6, in the range ±5 V with automatic Track-Hold modality.

Register DASL

This read only register allows to acquire the low byte of the last conversion performed by the A/D Converter; a read operation from this register will return bits 7÷0 of the last combination. Here follows the bits meaning:

D7	->	Bit 7 of combination
D6	->	Bit 6 of combination
D5	->	Bit 5 of combination
D4	->	Bit 4 of combination
D3	->	Bit 3 of combination
D2	->	Bit 2 of combination
D1	->	Bit 3 of combination
D0	->	Bit 2 of combination

Please remark that this register returns valid data only when a Track-Hold phase or a conversion are not in progress, that is only after the conversion has been completed.

Register DASH

This read only register allows to acquire the high byte of the last conversion performed by the A/D Converter; a read operation from this register will return bits 11÷8 of the last combination. Here follows the bits meaning:

D7	->	Not used
D6	->	Not used
D5	->	Not used
D4	->	Not used
D3	->	Bit 11 of combination (Unipolar mode) Sign of combination (Bipolar mode)
D2	->	Bit 10 of combination
D1	->	Bit 9 of combination
D0	->	Bit 8 of combination

Please remark that this register returns valid data only when a Track-Hold phase or a conversion are not in progress, that is only after the conversion has been completed.

Bit D3=C11 will contain the twelfth bit of the combination in case the conversion ranges are unipolar (0÷5 V, 0÷10 V) or the sign of the combination (**0** = positive, **1** = negative) in case the conversion ranges are bipolar (± 5 V, ± 10 V). This technique to code the sign meets the requirements of most programming languages, in fact it is the same normally used to code signed integers.

For further information please refer to the specific programs provided with the card.

Please remark that accessing any of the card registers implies deactivation of **ADC 812** interrupt signal.

EXAMPLE

For example, after a conversion in range ± 5 V register DASL reports 40H and register DASH reports 90H; the resulting combination is -140H = -320 decimal.

INITIALIZATION SEQUENCE

After a power on A/D converter section of **ADC 812** is in a status of total reset and is ready to receive a write to **DASCTRL** register to perform a conversion. In case the control board is simply reset (for example due to a manual reset or watchdog activation) **ADC 812** is not reset and keeps its previous status. This situation is not cause of problems because next writing to **DASCTRL** register will clear previous status starting a new conversion at the same time.

So, the board does not need an initialization procedure.

POLLING CONVERSION

Here follows a sequence of operations to perform a conversion on a channel of **ADC 812**. Conversion end is tested in a loop (polling) to wait for the possibility to begin another conversion.

- Write to **DASCTRL** register the data that specifies the desired conversion modalities (channel, range, Track-Hold, etc..).
- Wait for at least a conversion time ($\geq 9 \mu\text{sec}$).
- Read bits 8÷11 of the combination obtained from the conversion from register **DASH**.
- Read bits 0÷7 of the combination obtained from the conversion from register **DASL**.
- Elaborate the obtained combination

Here follows a sequence of operations to perform a conversion on a channel of **ADC 812**. Conversion end is tested in a loop (polling) to wait for the possibility to begin another conversion.

INTERRUPT CONVERSION

Here follows a sequence of operations to perform a conversion on a channel of **ADC 812**. Conversion end will generate an interrupt on **ABACO® I/O BUS** that will signal to control card the availability of the combination ready to be fetched.

Main program must contain:

- Write to **DASCTRL** register the data that specifies the desired conversion modalities (channel, range, Track-Hold, etc..).
- Elaborate the combination obtained from the interrupt handler routine

While the interrupt handler routine must contain:

- Read bits 8÷11 of the combination obtained from the conversion from register **DASH**.
- Read bits 0÷7 of the combination obtained from the conversion from register **DASL**.

NOTE

This latter conversion modality can be used only if the A/D section interrupt line is connected through jumper J1, as described in the previous chapters "INTERRUPT" and "JUMPERS".

EXTERNAL CARDS

ADC 812 can be connected to a wide range of block modules and operator interface system produced by **grifo**®, or to many system of other companies. The on board resources can be expanded with a simple connection to the numerous peripheral **grifo**® boards, both intelligent and not, thanks to its standard **BUS ABACO**® connector. Even cards with **ABACO**® I/O BUS can be connected, by using the proper mother boards.

Hereunder some of these cards are briefly described; ask the detailed information directly to **grifo**®, if required.

GPC® 323

General Purpose Controller 51 family

80C32 μ P, 14 MHz; Full CMOS; 1 RS 232 line (software); 1 RS 232 or RS 422-485 or Current Loop line; 24 TTL I/O lines; 11 A/D 12 bits lines; 3 Timers Counters; 64K EPROM; 64K RAM; 32K RAM and RTC backed; 32K DIL EEPROM; 8K serial EEPROM; Buzzer; 2 Activity LED; Watch dog; 5 readable DIPs; LCD Interface.

GPC® 553

General Purpose Controller 80C552

80C552 μ P, 22÷33 MHz; 1 RS 232 line (software); 1 RS 232 or RS 422-485 or Current Loop line; 16 TTL I/O lines; 8 A/D 10 bits lines; 3 Timers Counters; 64K EPROM; 64K RAM; 32K RAM and RTC backed; 32K DIL EEPROM; 8K serial EEPROM; 2 PWM lines; 1 Activity LED; Watch dog; 5 readable DIPs; LCD Interface.

GPC® 153

General Purpose Controller Z80

84C15 μ P, 10÷16 MHz; Full CMOS; 1 RS 232 line; 1 RS 232 or RS 422-485 or Current Loop line; 16 TTL I/O lines; 8 A/D 12 bits lines; 2÷4 Timers Counters; 512K EPROM or FLASH; 512K RAM and RTC backed; 8K serial EEPROM; Buzzer; 1 Activity LED; Watch dog; 8 readable DIPs; LCD Interface.

GPC® 183

General Purpose Controller Z180

Z180 μ P, 10÷16 MHz; Full CMOS; 1 RS 232 line; 1 RS 232 or RS 422-485 or Current Loop line; 24 TTL I/O lines; 11 A/D 12 bits lines; 2 Timers Counters; 512K EPROM or FLASH; 512K RAM and RTC backed; 8K serial EEPROM; Buzzer; 2 Activity LED; Watch dog; 4 readable DIPs; LCD Interface.

GPC® 324/D

“4” Type General Purpose Controller 80C32/320

80C32 or 80C320 μ P, 14÷22 MHz; Full CMOS; 1 RS 232 line; 1 RS 232 or RS 422-485 or Current Loop line; 4÷16 TTL I/O lines; 3 Timers Counters; 64K EPROM; 64K RAM; 32K RAM backed; 32K DIL E2; 8K serial EEPROM; Watch dog; 1 readable DIP; LCD Interface; Abaco® I/O BUS; 5Vdc Power supply; Size: 100x50 mm.

ABB 03

ABACO® Block BUS 3 slots

3 slots **ABACO**® mother board; 4 TE pitch connectors; **ABACO**® I/O BUS connector; screw terminal for power supply; connection for DIN C type and Ω rails.

ABB 05**ABACO® Block BUS 5 slots**

5 slots **ABACO®** mother board with power supply. Double power supply built in; 5Vdc 2,5A section for powering the on board logic; second section at 24Vdc 400mA galvanically coupled, for the optocoupled input lines. Auxiliary connector for **ABACO®** I/O BUS. Connection for DIN Ω rails.

GPC® 554**General Purpose Controller 80C552**

Microprocessor 80C552 at 22 MHz; implementation completely CMOS; 32K EPROM; 32 K SRAM; 32 K EEPROM or SRAM; EEPROM; 2 RS 232 serial lines; 16 I/O TTL; 2 PWM lines; 16 bits Timer/Counter; Watch Dog; 6 signals A/D converter with resolution 10 bit; interface for **ABACO®** I/O BUS.

GPC® 154**“4” Type General Purpose Controller Z80**

84C15 μ P, 10÷16 MHz; Full CMOS; 1 RS 232 line; 1 RS 232 or RS 422-485 line; 16 TTL I/O lines; 2÷4 Timers Counters; 512K EPROM or FLASH; 512K RAM and RTC backed; 8K serial EEPROM; Watch dog; 2 readable DIPs; LCD Interface; Abaco® I/O BUS; 5Vdc Power supply; Size: 100x50 mm.

GPC® 884**General Purpose Controller Am188ES**

Microprocessor AMD Am188ES up to 40 MHz 16 bits; implementation completely CMOS; serie 4 format; 512K EPROM or FLASH; 512K SRAM backed with Lithium battery; RTC; 1 RS 232 serial line + 1 RS 232 or RS 422-485 or current loop; 16 I/O TTL; 3 timer/counter; watch dog; EEPROM; 11 signals A/D converter with 12 bit resolution; interface for **ABACO®** I/O BUS.

GPC® 114**General Purpose Controller 68HC11**

Microprocessor 68HC11A1 at 8 MHz; implementation completely CMOS; serie 4 format; 32K EPROM; 32K SRAM backed with Lithium battery; 32K EPROM, SRAM, EEPROM; RTC; 1 serial line RS 232 or RS 422-485; 10 I/O TTL; 3 timer/counter; watch dog; 8 signals A/D converter with resolution 8 bit; 1 asynchronous serial line; extremely low power consumption; interface for **ABACO®** I/O BUS.

GPC® 184**General Purpose Controller Z80195**

Microprocessor Z80195 at 22 MHz; implementation completely CMOS; 512K EPROM or FLASH; 512K RAM; Back-Up with Lithium battery internal or external; 1 serial line RS 232 + 1 RS 232 or RS 422-485 or current loop + 1 TTL; 18 I/O TTL; 4 timer/counter 8 bits; 2 timer 16 bits; Watch Dog; Real Time Clock; activity LED; EEPROM; interface for **ABACO®** I/O BUS.

GPC® AM4**General Purpose Controller ATmega103**

Microprocessor ATmega103 at 5.5 MHz; implementation completely CMOS; 128K internal FLASH; 32K SRAM; Back-Up with Lithium battery internal or external; 1 serial line RS 232 or RS 422-485 or current loop; 16 I/O TTL; 8 linee A/D resolution 10 bits; 2 timer/counter; Watch Dog; Real Time Clock; 4K internal EEPROM; interface for ISP programming; interface for **ABACO®** I/O BUS.

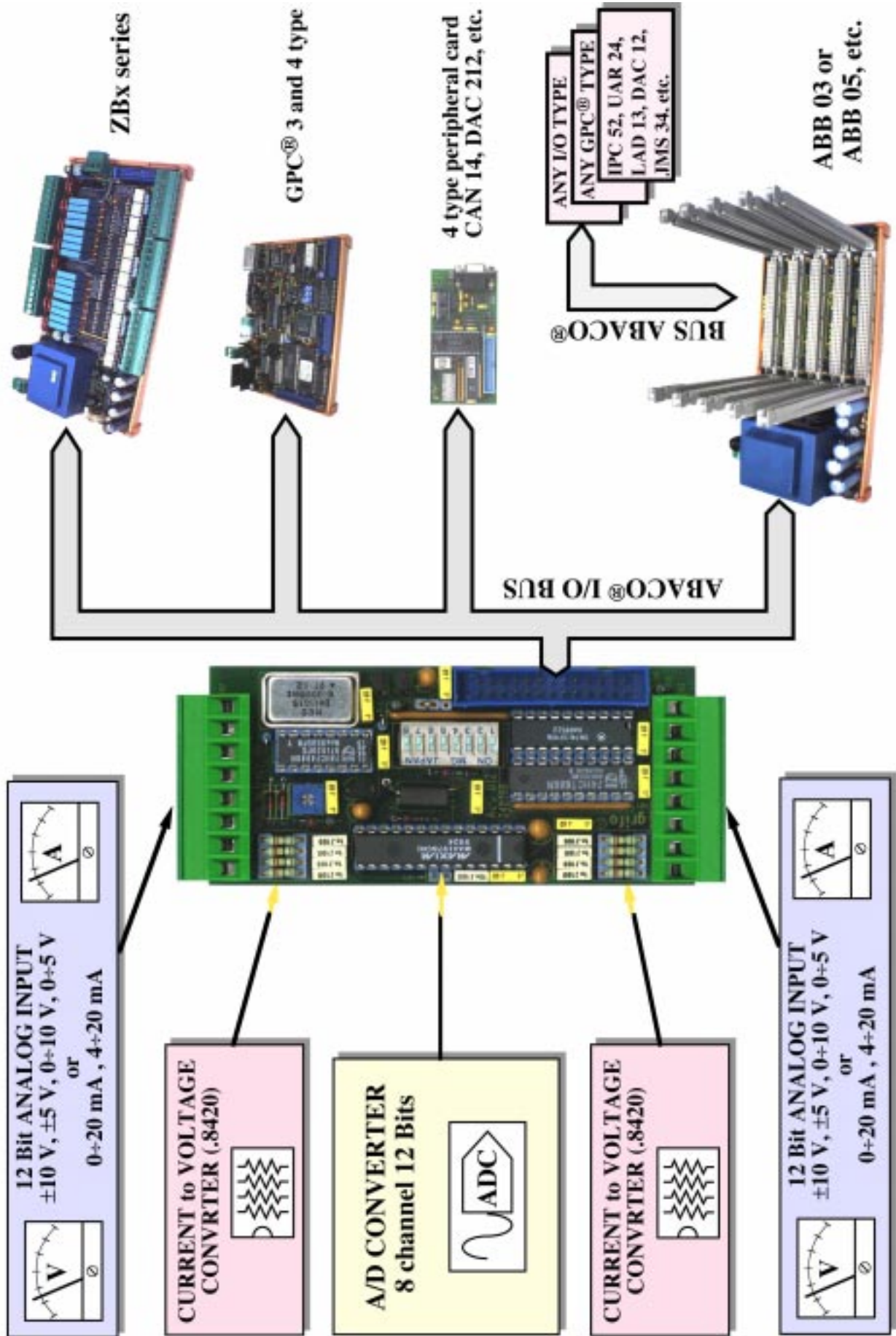

FIGURE 12. POSSIBLE CONNECTIONS DIAGRAM

GPC® 51

General Purpose Controller fam. 51

Microprocessor family 51 INTEL including the masked BASIC chip; the board features: 16 I/O TTL lines; dip switch; 3 timer/counter; RS 232; 4 A/D converter signals resolution 11 bit; buzzer; on board EPROM programmer; RTC and 32K SRAM with Lithium battery back up; controller for display and keyboard.

GPC® 188F

General Purpose Controller 80C188

80C188 μ P 20MHz; 1 RS 232 line; 1 RS 232, RS 422-485 or Current Loop line; 24 TTL I/O lines; 1M EPROM or 512K FLASH; 1M RAM Lithium battery backed; 8K serial EEPROM; RTC; Watch Dog; 8 Dip switch; 3 Timer Counter; 8 13 bit A/D lines; Power failure; activity LEDs; single power supply +5Vdc.

GPC® 15A

General Purpose Controller 84C15

Full CMOS card, 10÷20 MHz 84C15 CPU; 512K EPROM or FLASH; 128K RAM; 8K RAM and RTC backed; 8K serial EEPROM; 1 RS 232 line; 1 RS 232 line or RS 422-485 or Current Loop line; 32 or 40 TTL I/O lines; CTC; Watch dog; 2 Dip switches; Buzzer.

GPC® 150

General Purpose Controller 84C15

Microprocessor Z80 at 16 MHz; implementation completely CMOS; 512K EPROM or FLASH; 512K SRAM; RTC; Back-Up through external Lithium battery; 4M serial FLASH; 1 serial line RS 232 plus 1 RS 232 or RS 422-485 or current loop; 40 I/O TTL; 2 timer/counter; 2 watch dog; dip switch; EEPROM; A/D converter with resolution 12 bit; activity LED.

GPC® 15R

General Purpose Controller 84C15

84C15 μ P, 10÷16 MHz; 1 RS 232 line; 1 RS 232 or RS 422-485 or C. L. line; 16÷24 TTL I/O lines; 16 Opto-in; 8 Relays; 4 Opto Coupled Timers Counters; 512K EPROM or FLASH; 512K RAM and RTC backed; 8K serial EEPROM; 8K Backed RAM modul; Buzzer; 1 Activity LED; Watch dog; 4÷12 readable DIPs; LCD Interface.

SPC 03.5S

Switch Power Card +5 Vdc

Europe format switching power supply capable to provide +5 Vdc to a load of 4 A; input voltage 12÷24 Vac; power-failure; connector for back-up battery; standard connector for mother board **SPB 0x**.

SPC 512

Switch Power Card +5 Vdc +12 Vdc

Europe format switching power supply capable to provide +5 Vdc 5A and +12 Vdc 2.5 A; input voltage 12÷24 Vac; power-failure; connector for back-up battery; standard connector for mother board **SPB 0x**.

BIBLIOGRAPHY

Here follows a list of manuals that can be a source of further information about the devices installed on **ADC 812**.

Manual TEXAS INSTRUMENTS: *The TTL Data Book - SN54/74 Families*

Manual MAXIM: *New Releases Data Book 1996 - Volume V*

Manual NATIONAL SEMICONDUCTOR: *DataBook - Linear 2*

Please connect to the manufacturers' Web sites to get the latest version of all manuals and data sheets.



APPENDIX A: ALPHABETICAL INDEX

SYMBOLS**+ 5VDC 15****A**

A/D CONVERSION TIME 7
A/D CONVERTER 4, 10, 12, 18, 19
A/D CUT OFF FREQUENCY 7
A/D EXAMPLE 20
A/D INITIALIZATION SEQUENCE 22
A/D INPUT IMPEDANCE 7
A/D INPUTS 7, 14
A/D INTERRUPT CONVERSION 22
A/D POLLING CONVERSION 22
A/D RESOLUTION 7
A/D VOLTAGE POLARITY 20
A/D VOLTAGE RANGE 20
ABACO® I/O BUS 7, 13, 15, 16, 22, 23
ADDRESSING 6, 18
ADDRESSING SPACE 7, 18

B

BIBLIOGRAPHY 27
BLOCK DIAGRAM 5
BUS 7
BUS ABACO® 23
BYTES TAKEN 7

C

CALIBRATION 8
CARD VERSION 1
CONNECTORS 7
 CN1 13
 CN2 10
 CN3 12
CONSUMPTION 7

D

DASCTRL 19
DASH 21
DASL 20
DIFFERENTIAL INPUT ERROR 7
DIN 46277-1 AND 3 16
DSW1 6, 17, 18



E

EXTERNAL CARDS 23

F

FILTERS 4

I

I/O CONNECTION 14

INPUT FILTERS 4

INTERFACING 6

INTERRUPT 15, 16

J

JUMPERS 15

L

LINEARITY MAXIMUM ERROR 7

M

MAPPING 17

MECHANICAL MOUNTING 16

MOUNTING 16

O

OFFSET MAXIMUM ERROR 7

ON BOARD RESOURCES 7

OSCILLATOR FREQUENCY 7

P

POWER SUPPLY 7, 15

R

REFERENCE VOLTAGE 6

RELATIVE HUMIDITY 7

RESOURCES 7

RV1 8

S

SIZE 7

T

TEMPERATURE RANGE 7

TEST POINT 8

TP1 8

TRIMMER 8

TTL 14

V

VOLTAGE REFERENCE 8

VOLTAGE-CURRENT CONVERSION MODULE 14

VREF 8

W

WEIGHT 7

WORK FREQUENCY 7

