

**OBI N8 OBI P8
RBO 08 RBO 16
TBO 08
XBI R4 XBI T4**
BLOCK Input/Output

TECHNICAL MANUAL

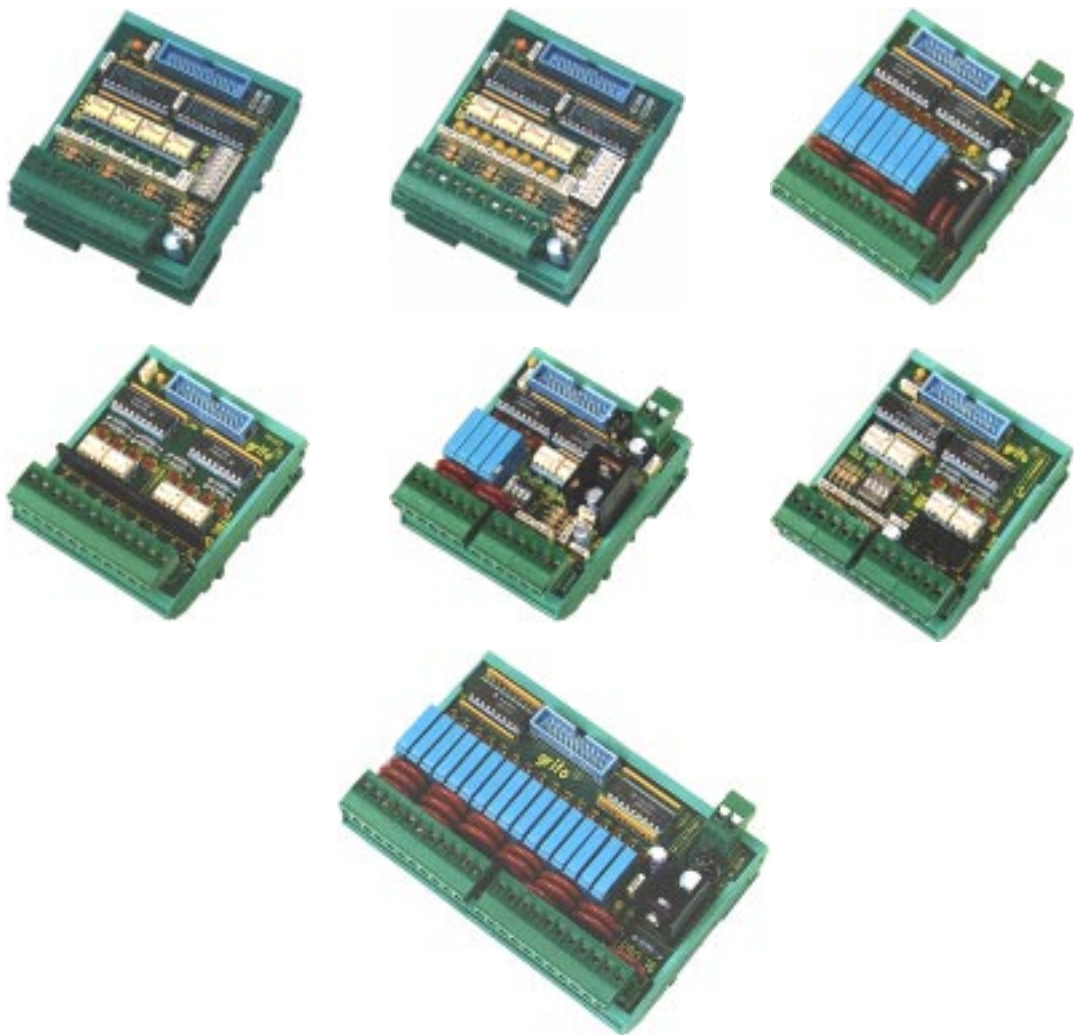

grifo[®]
ITALIAN TECHNOLOGY

Via dell' Artigiano, 8/6
40016 San Giorgio di Piano
(Bologna) ITALY
E-mail: grifo@grifo.it



<http://www.grifo.it> <http://www.grifo.com>
Tel. +39 051 892.052 (a. r.) FAX: +39 051 893.661

OBI N8/P8, RBO 08/16, TBO 08, XBI R4/T4 Edition 5.10 Rel. 12 September 2000

, GPC[®], grifo[®], are trade marks of grifo[®]

**OBI N8 OBI P8
RBO 08 RBO 16
TBO 08
XBI R4 XBI T4
BLOCK Input/Output**

TECHNICAL MANUAL

OBI N8-P8

Opto BLOCK Input NPN-PNP

Interface for 8 optocoupled and visualized inputs type NPN or PNP; quick release screw terminal connector for optocoupled inputs; standard connector 20 pins I/O **ABACO**[®]; 8 LEDs for visualization; opto power supply section +12÷+24 Vdc; quick connection for DIN 46277-1 and 3 rails.

RBO 08-16

Relé BLOCK Output

Interface for standard connector 20 pins I/O **ABACO**[®]; 8 or 16 outputs visualized featuring 3A relays with MOV; one or two quick release screw terminal connector for relays outputs; 8 or 16 LEDs for visualization; power supply +12 Vdc or +24 Vdc; quick connection for DIN 46277-1 and 3 rails.

TBO 08

Transistor BLOCK Output

Interface for standard connector 20 pins I/O **ABACO**[®]; 8 outputs visualized featuring optocoupled Open Collector 3A transistors; quick release screw terminal connector for transistor outputs; 8 LEDs for visualization; quick connection for DIN 46277-1 and 3 rails.

XBI R4-T4

miXed BLOCK Inpu/output

Interface for standard connector 20 pins I/O **ABACO**[®]; four 3A relays with MOV or four 3A optocoupled Open Collector transistors; 4 optocoupled input lines; 8 LEDs for visualization of Input/Output; two quick release screw terminal connector for I/O; quick connection for DIN 46277-1 and 3 rails.

grifo[®]

ITALIAN TECHNOLOGY

Via dell' Artigiano, 8/6
40016 San Giorgio di Piano
(Bologna) ITALY
E-mail: grifo@grifo.it



<http://www.grifo.it> <http://www.grifo.com>
Tel. +39 051 892.052 (a. r.) FAX: +39 051 893.661

OBI N8/P8, RBO 08/16, TBO 08, XBI R4/T4 Edition 5.10 Rel. 12 September 2000

, **GPC**[®], **grifo**[®], are trade marks of **grifo**[®]

DOCUMENTATION COPYRIGHT BY grifo®, ALL RIGHTS RESERVED

No part of this document may be reproduced, transmitted, transcribed, stored in a retrieval system, or translated into any language or computer language, in any form or by any means, either electronic, mechanical, magnetic, optical, chemical, manual, or otherwise, without the prior written consent of **grifo®**.

IMPORTANT

Although all the information contained herein have been carefully verified, **grifo®** assumes no responsibility for errors that might appear in this document, or for damage to things or persons resulting from technical errors, omission and improper use of this manual and of the related software and hardware.

grifo® reserves the right to change the contents and form of this document, as well as the features and specification of its products at any time, without prior notice, to obtain always the best product.

For specific informations on the components mounted on the card, please refer to the Data Book of the builder or second sources.

SYMBOLS DESCRIPTION

In the manual could appear the following symbols:



Attention: Generic danger



Attention: High voltage

Trade Marks

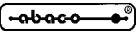
 , GPC®, **grifo®** : are trade marks of **grifo®**.

Other Product and Company names listed, are trade marks of their respective companies.

GENERAL INDEX

INTRODUCTION 1

CARD VERSION 1

MANUAL INTRODUCTION 2

OBI N8 3

TECHNICAL FEATURES 3

CN1 - I/O ABACO® CONNECTOR 4

CN2 - INPUT CONNECTOR..... 6

HARDWARE DESCRIPTION..... 8

ON BOARD JUMPERS 8

VISUALIZATIONS..... 8

SOFTWARE DESCRIPTION 10

I/O CONNECTIONS..... 10

OBI P8 11

TECHNICAL FEATURES 11

CN1 - I/O ABACO® CONNECTOR 12

CN2 - INPUT CONNECTOR..... 14

HARDWARE DESCRIPTION..... 16

ON BOARD JUMPERS 16

VISUALIZATIONS..... 16

SOFTWARE DESCRIPTION 18

I/O CONNECTIONS..... 18

RBO 08 19

TECHNICAL FEATURES 19

CN2 - I/O ABACO® CONNECTOR 20

CN1 - RELAYS SUPPLY CONNECTOR 21

CN3 - OUTPUT CONNECTOR..... 22

HARDWARE DESCRIPTION..... 24

ON BOARD JUMPERS 24

VISUALIZATIONS..... 26

SOFTWARE DESCRIPTION 26

I/O CONNECTIONS..... 27



RBO 16	28
TECHNICAL FEATURES	28
CN2 - I/O ABACO® CONNECTOR	29
CN3 - OUTPUTS 8÷15 CONNECTOR	31
CN4 - OUTPUTS 0÷7 CONNECTOR	33
CN1 - RELAYS SUPPLY CONNECTOR	35
HARDWARE DESCRIPTION	35
ON BOARD JUMPERS	35
VISUALIZATIONS	36
SOFTWARE DESCRIPTION	36
I/O CONNECTIONS	37
TBO 08	38
TECHNICAL FEATURES	38
CN1 - I/O ABACO® CONNECTOR	39
CN2 - OUTPUT CONNECTOR	41
HARDWARE DESCRIPTION	43
ON BOARD JUMPERS	43
VISUALIZATIONS	45
SOFTWARE DESCRIPTION	45
I/O CONNECTIONS	46
XBI R4	47
TECHNICAL FEATURES	47
CN1 - RELAYS SUPPLY CONNECTOR	48
CN2 - I/O ABACO® CONNECTOR	50
CN3 - INPUT CONNECTOR	52
CN4 - OUTPUT CONNECTOR	54
HARDWARE DESCRIPTION	55
VISUALIZATIONS	55
SOFTWARE DESCRIPTION	56
ON BOARD JUMPERS	56
I/O CONNECTIONS	57
XBI T4	58
TECHNICAL FEATURES	58
CN1 - I/O ABACO® CONNECTOR	59
CN2 - OUTPUT CONNECTOR	61
CN3 - INPUT CONNECTOR	63
HARDWARE DESCRIPTION	65
I/O CONNECTIONS	65
SOFTWARE DESCRIPTION	66
VISUALIZATIONS	66
EXTERNAL CARDS	67
BIBLIOGRAPHY	71
APPENDIX A: ALPHABETICAL INDEX	A-1

FIGURES INDEX

FIGURE 1: CN1 - I/O ABACO® CONNECTOR	4
FIGURE 2: OBI N8 BLOCK DIAGRAM	5
FIGURE 3: CN2 - INPUT CONNECTOR	6
FIGURE 4: OBI N8 CARD PHOTO	7
FIGURE 5: OBI N8 COMPONENTS MAP	7
FIGURE 6: OBI N8 LEDS TABLE	8
FIGURE 7: OBI N8 JUMPERS, CONNECTORS, LEDS ETC. LOCATION	9
FIGURE 8: CN1 - I/O ABACO® CONNECTOR	12
FIGURE 9: OBI P8 BLOCK DIAGRAM	13
FIGURE 10: CN2 - INPUT CONNECTOR	14
FIGURE 11: OBI P8 CARD PHOTO	15
FIGURE 12: OBI P8 COMPONENTS MAP	15
FIGURE 13: OBI P8 LEDS TABLE	16
FIGURE 14: OBI P8 JUMPERS, CONNECTORS, LEDS ETC. LOCATION	17
FIGURE 15: CN2 - I/O ABACO® CONNECTOR	20
FIGURE 16: CN1 - RELAYS SUPPLY CONNECTOR	21
FIGURE 17: RBO 08 BLOCK DIAGRAM	21
FIGURE 18: CN3 - OUTPUT CONNECTOR	22
FIGURE 19: RBO 08 CARD PHOTO	23
FIGURE 20: RBO 08 COMPONENTS MAP	23
FIGURE 21: RBO 08 JUMPERS, CONNECTORS, LEDS ETC. LOCATION	25
FIGURE 22: RBO 08 LEDS TABLE	26
FIGURE 23: CN2 - I/O ABACO® CONNECTOR	29
FIGURE 24: RBO 16 BLOCK DIAGRAM	30
FIGURE 25: CN3 - OUTPUTS 8÷15 CONNECTOR	31
FIGURE 26: RBO 16 CARD PHOTO	32
FIGURE 27: RBO 16 COMPONENTS MAP	32
FIGURE 28: CN4 - OUTPUTS 0÷7 CONNECTOR	33
FIGURE 29: RBO 16 JUMPERS, CONNECTORS, LEDS ETC. LOCATION	34
FIGURE 30: CN1 - RELAYS SUPPLY CONNECTOR	35
FIGURE 31: RBO 16 LEDS TABLE	36
FIGURE 32: CN1 - I/O ABACO® CONNECTOR	39
FIGURE 33: TBO 08 BLOCK DIAGRAM	40
FIGURE 34: CN2 - OUTPUT CONNECTOR	41
FIGURE 35: TBO 08 CARD PHOTO	42
FIGURE 36: TBO 08 COMPONENTS MAP	42
FIGURE 37: TBO 08 JUMPERS, CONNECTORS, LEDS ETC. LOCATION	44
FIGURE 38: TBO 08 LEDS TABLE	45
FIGURE 39: CN1 - RELAYS SUPPLY CONNECTOR	48
FIGURE 40: XBI R4 BLOCK DIAGRAM	49
FIGURE 41: CN2 - I/O ABACO® CONNECTOR	50
FIGURE 42: XBI R4 CARD PHOTO	51
FIGURE 43: XBI R4 COMPONENTS MAP	51
FIGURE 44: CN3 - INPUT CONNECTOR	52
FIGURE 45: XBI R4 JUMPERS, CONNECTORS, LEDS ETC. LOCATION	53
FIGURE 46: CN4 - OUTPUT CONNECTOR	54

FIGURE 47: XBI R4 LEDS TABLE	55
FIGURE 48: CN1 - I/O ABACO® CONNECTOR	59
FIGURE 49: XBI T4 BLOCK DIAGRAM	60
FIGURE 50: CN2 - OUTPUT CONNECTOR	61
FIGURE 51: XBI T4 CARD PHOTO	62
FIGURE 52: XBI T4 COMPONENTS MAP	62
FIGURE 53: CN3 - INPUT CONNECTOR	63
FIGURE 54: XBI T4 JUMPERS, CONNECTORS, LEDS ETC. LOCATION	64
FIGURE 55: XBI T4 LEDS TABLE	66

INTRODUCTION

The use of these devices has turned - IN EXCLUSIVE WAY - to specialized personnel.

The purpose of this handbook is to give the necessary information to the cognizant and sure use of the products. They are the result of a continual and systematic elaboration of data and technical tests saved and validated from the manufacturer, related to the inside modes of certainty and quality of the information.

The reported data are destined- IN EXCLUSIVE WAY- to specialized users, that can interact with the devices in safety conditions for the persons, for the machine and for the environment, impersonating an elementary diagnostic of breakdowns and of malfunction conditions by performing simple functional verify operations , in the height respect of the actual safety and health norms.

The informations for the installation, the assemblage, the dismantlement, the handling, the adjustment, the reparation and the contingent accessories, devices etc. installation are destined - and then executable - always and in exclusive way from specialized warned and educated personnel, or directly from the TECHNICAL AUTHORIZED ASSISTANCE, in the height respect of the manufacturer recommendations and the actual safety and health norms.

The devices can't be used outside a box. The user must always insert the cards in a container that respect the actual safety normative. The protection of this container is not threshold to the only atmospheric agents, but specially to mechanic, electric, magnetic, etc. ones.

To be on good terms with the products, is necessary guarantee legibility and conservation of the manual, also for future references. In case of deterioration or more easily for technical updates, consult the AUTHORIZED TECHNICAL ASSISTANCE directly.

To prevent problems during card utilization, it is a good practice to read carefully all the informations of this manual. After this reading, the user can use the general index and the alphabetical index, respectly at the begining and at the end of the manual, to find information in a faster and more easy way.

CARD VERSION

The present manual is reported to the following cards:

OBI N8	version	120794 and later,
OBI P8	version	120794 and later,
RBO 08	version	170895 and later,
RBO 16	version	180895 and later,
TBO 08	version	170895 and later,
XBI R4	version	170895 and later,
XBI T4	version	170895 and later,

The validity of the bring informations is subordinate to the number of the card release. The user must always verify the correct correspondence among the two denotations. Version number is printed on the boards in several positions both in serigraph and in printed circuit.

MANUAL INTRODUCTION

The present manual reports information about some **BLOCK** serie modules: **TBO 08**, **XBI T4**, **XBI R4**, **RBO 08**, **RBO 16**, **OBI N8** and **OBI P8**. These block allow to solve the most common problems of connecting electronic devices to the external world.

The following chapters will show the several blocks singularly, explaining electrical and physical features, connection, supplying and use modalities. Also, the meaning of the several LEDs installed on the modules will be described.

About connectors location and their enumeration, please always refer to the serigraph printed on the boards; should this not be readable please refer to the components maps contained in this manual.

NOTE

In the pin out description of standard 20 pins I/O **ABACO**® connector, some signals are called port 1 and 2. For this pin out has been made a standard, all the boards provided with a connector compliant to this standard can be connected to **BLOCK** serie modules, even if the signals name is different. For example, on the boards provided with PPI 8255, the port A on the 20 pins connector corresponds to port 1 on **BLOCK** serie modules and port B corresponds to port 2.

OBI N8

OBI N8 (Optocoupled Block 8 Input NPN) is a **BLOCK** serie module designed to manage and visualize 8 optocoupled inputs, NPN type, by 8 TTL digital signals.

The 8 input TTL and the +5Vdc needed to supply the digital section, are available through a standard 20 pins I/O **ABACO**® connector, allowing to interface to the several **grifo**® cards, like **GPC**® **F2**, **GPC**® **51**, **GPC**® **552**, **GPC**® **011**, **GPC**® **188**, **PIO 01**, **IAC 01**, etc.

The 8 optocoupled inputs are available on a 10 pins quick release screw terminal connector, that allows to interface promptly to the external world.

Through this same connector it is also possible to supply the input optocouplers section, this supply tension can vary in the range +12÷+24 Vdc.

The board features 8 green LEDs that provide the User a visual feed back about the status of the 8 signals available on the module.

OBI N8 is delivered with a plastic mount for DIN 46277-1 and DIN 46277-3 rails.

TECHNICAL FEATURES

N. of NPN optocoupled input lines:	8
N. of TTL signals:	8
Size:	70 x 80 x 40 mm
Weight:	120 g
Connectors:	CN1 vertical low profile M 20 pins CN2 quick release screw terminal 10 pins
Temperature range:	from 0 to 50 centigrad dereeses
Relative humidity:	20% up to 90% without condense
Buffer power supply:	+5 Vdc
NPN optocoupled input section power supply tension:	in the range +12 ÷ +24 Vdc
Current consumption on +5 Vdc:	70 mA max

CN1 - I/O ABACO® CONNECTOR

CN1 is a 20 pins low profile male connector, featuring standard I/O ABACO® pin out, where 16 digital I/O TTL signals are available, divided in two ports.

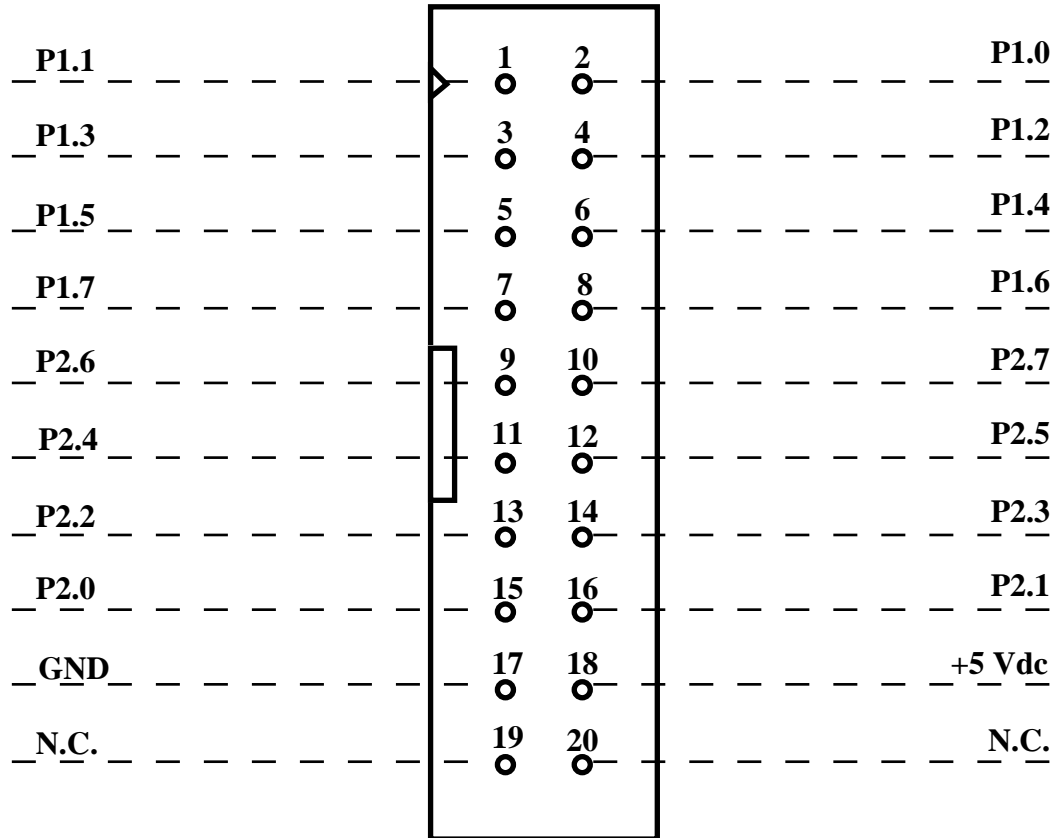

FIGURE 1: CN1 - I/O ABACO® CONNECTOR

Signals description:

P1.n	=	I/O	- n-th signals of port 1.
P2.n	=	I/O	- n-th signals of port 2.
+5 Vdc	=	I/O	- Power supply +5 Vdc.
GND	=		- Ground.
N.C.	=		- Not connected.

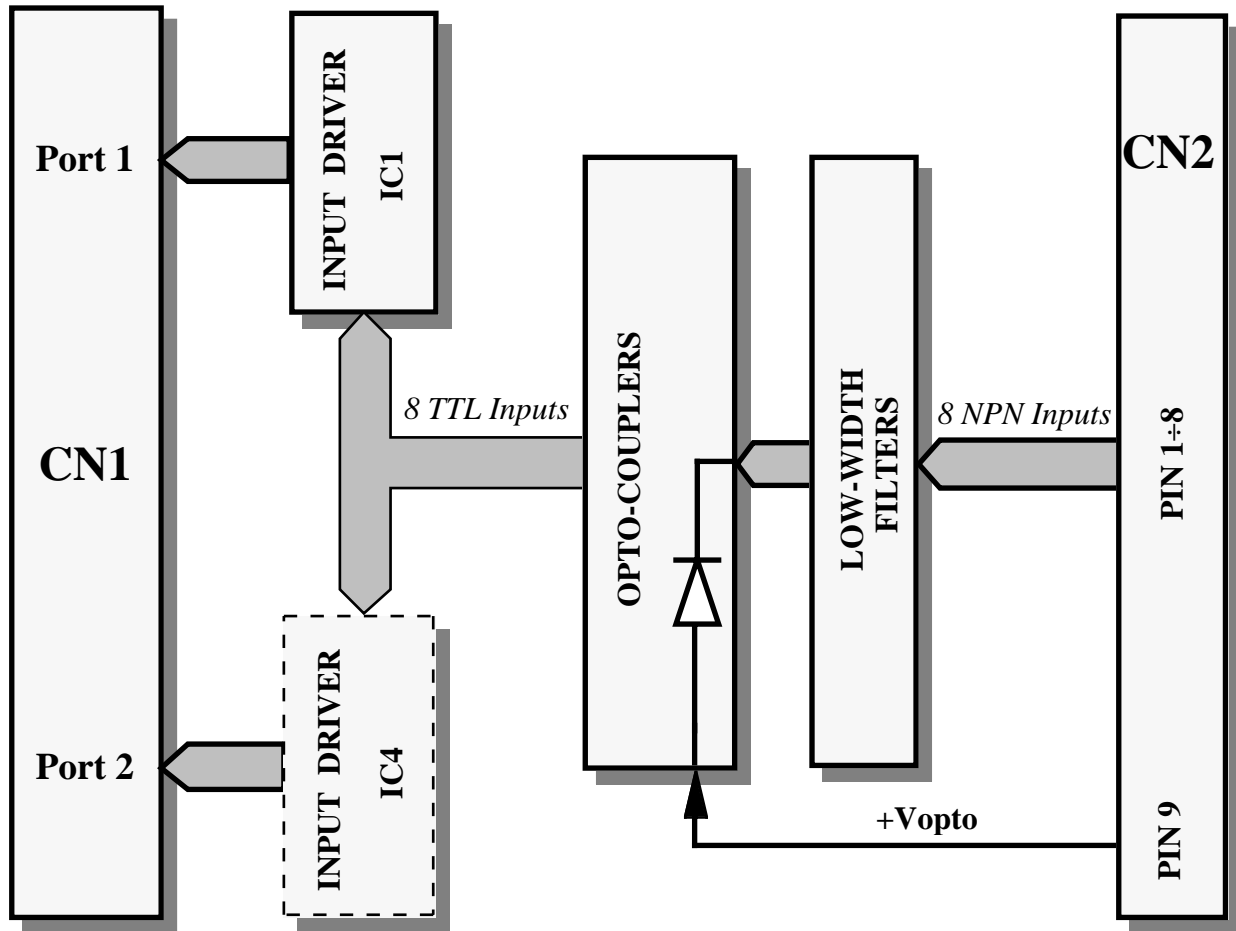

FIGURE 2: OBI N8 BLOCK DIAGRAM

CN2 - INPUT CONNECTOR

CN2 is a 10 pins quick release screw terminal connector, used to connect the 8 NPN optocoupled inputs and the external world.

The following figure refers to a view of the connector from the component side.

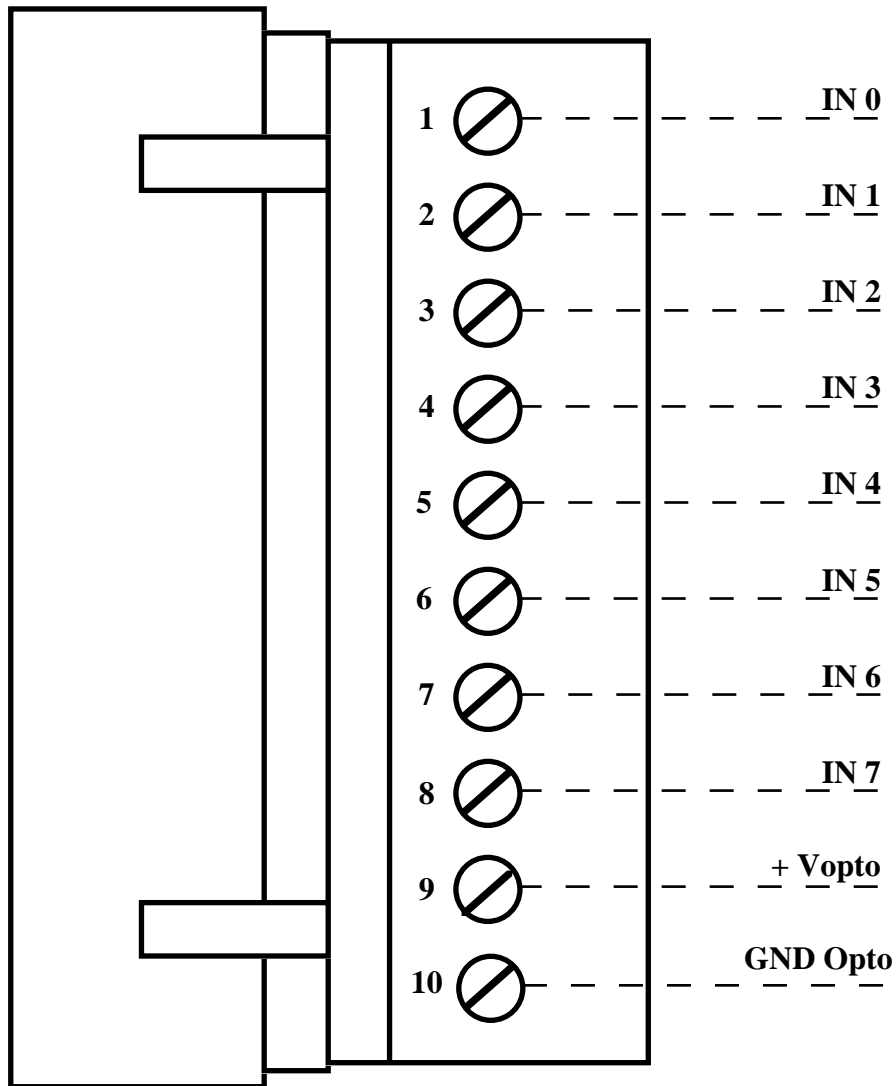

FIGURE 3: CN2 - INPUT CONNECTOR

Signals description:

- IN n** = I - n-th NPN input corresponding to signal P?.n on connector CN1
- +Vopto** = I - Power supply of optocoupled NPN input section i i range 12÷24 Vdc.
- GND Opto** = - Ground signal for NPN optocoupled inputs.

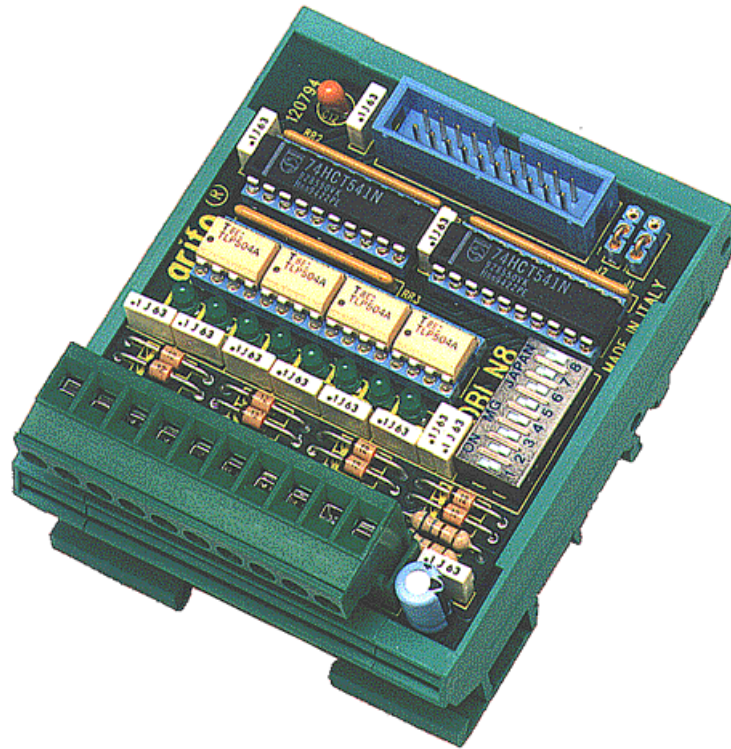

FIGURE 4: OBI N8 CARD PHOTO

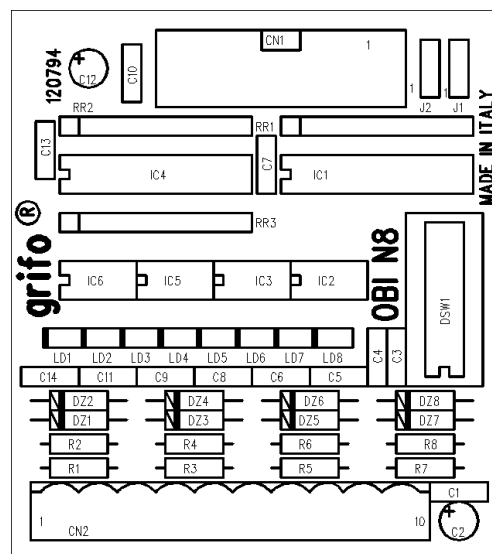

FIGURE 5: OBI N8 COMPONENTS MAP

HARDWARE DESCRIPTION

OBI N8 can interface both port 1 and port 2 available on the 20 pins connector simply moving the buffer 74HCT541 from socket IC1 to socket IC4. When the buffer is installed on **IC1**, the 8 optocoupled NPN input signals can be fetched from **port 1** and viceversa when such component is installed on **IC4**, the inputs are interfaced to **port 2**. The choice of which port to use can be done by the User according to his/her specific needs, being careful not to create electric conflicts when many modules of this family are installed at the same time.

The power to supply the input optocouplers must be provided between pin 9 and 10 of input connector CN2; this supply tension must be in the range from +12 Vdc to +24 Vdc.

ON BOARD JUMPERS

On **OBI N8** module two 3 pins Jumpers, called **J1** and **J2**, are installed. They allow to connect the signals of Port 1 and 2 of CN1 to PULL-UP or PULL-DOWN resistors; in detail the description of these jumpers is the following:

- J1** pos. 1-2: Connects signals of Port 1 to 8 PULL-UP resistors
pos. 2-3: Connects signals of Port 1 to 8 PULL-DOWN resistors
- J2** pos. 1-2: Connects signals of Port 2 to 8 PULL-UP resistors
pos. 2-3: Connects signals of Port 2 to 8 PULL-DOWN resistors

The port used by **OBI N8** to deliver the signals must be connected to PULL-UP resistors, so if the module uses port 1 (74HCT541 installed on IC1), jumper J1 must be in position 1-2; viceversa if the module **OBI N8** uses port 2 (74HCT541 installed on IC4), jumper J2 must be in position 1-2.

The port not used must be configured according the boards that are going to be connected to it; in particular if it will be connected to boards featuring Output signals (**RBO 01**, **RBO 08**, **TBO 08**, **XBI T4**, **XBI R4**, etc.), the corresponding Jumper will have to be in position 2-3, if it will be connected to boards featuring Input signals (another **OBI N8**, **OBI P8**, etc.), the Jumper will have to be in position 1-2.

VISUALIZATIONS

OBI N8 module is provided with eight signalation LEDs to show status information about its signals, as described in the following table:

LEDs	COLOUR	PURPOSE
LD1÷LD8	Green	Visualize the status of the eight optocoupled input signals, respectively IN0÷IN7. A LED on indicates the input contact is connected to GND Opto.

FIGURE 6: **OBI N8** LEDs TABLE

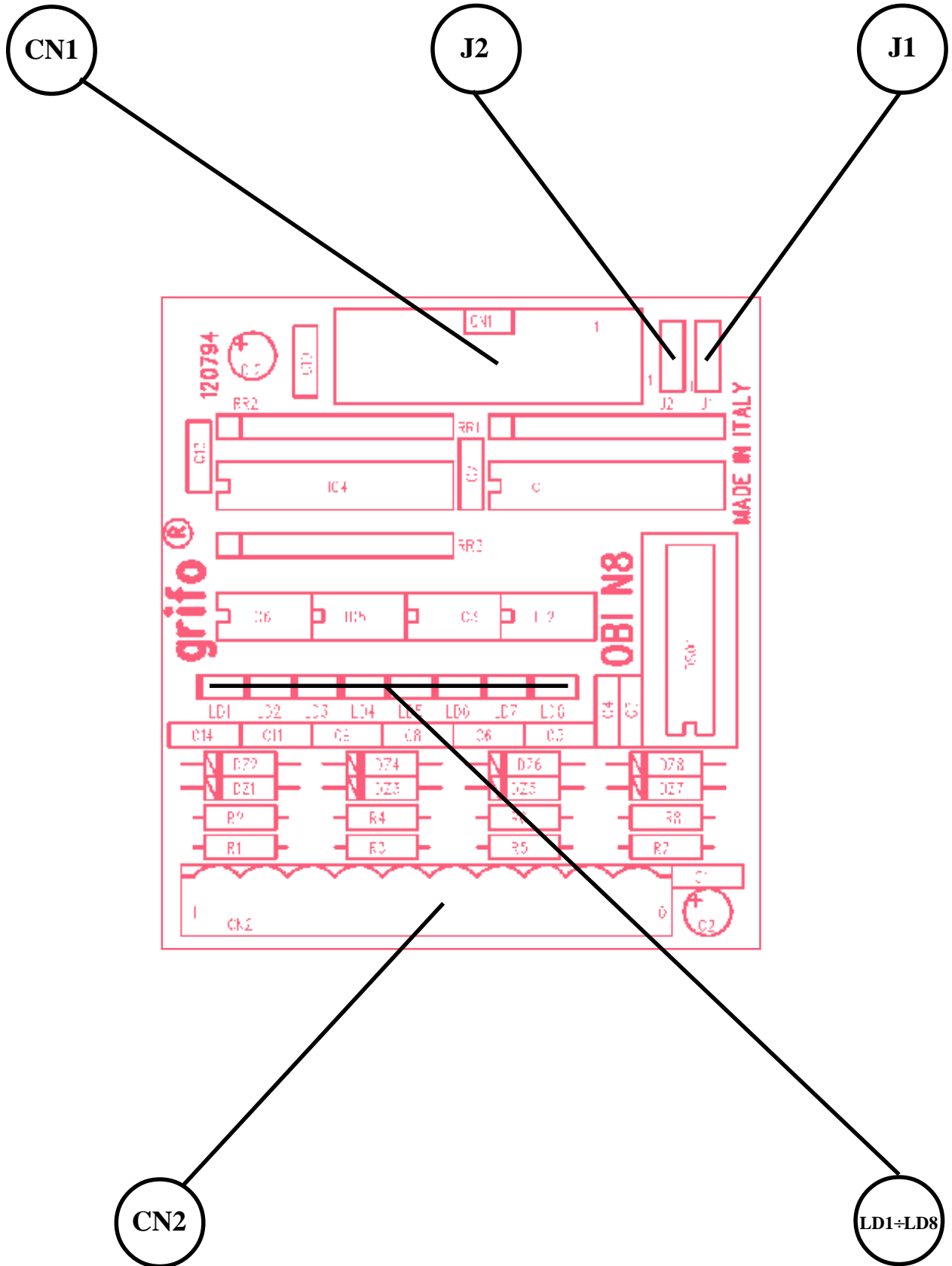

FIGURE 7: OBI N8 JUMPERS, CONNECTORS, LEDS ETC. LOCATION

SOFTWARE DESCRIPTION

The 8 NPN optocoupled inputs available on **OBI N8**, are acquired directly from the bits 0÷7 of the selected port; in detail the correspondance between bit and input is the following:

Port ?.0	->	IN0
Port ?.1	->	IN1
Port ?.2	->	IN2
Port ?.3	->	IN3
Port ?.4	->	IN4
Port ?.5	->	IN5
Port ?.6	->	IN6
Port ?.7	->	IN7

Where ? indicates port 1 or 2, according to which socket the component 74HCT541 is installed on, as previously described.

The correspondance between logic status of bits and signals status is the following:

Bit at logic 0	->	Input activated	=	Input contact connected to GND opto
Bit at logic 1	->	Input not activated	=	Input contact not connected

I/O CONNECTIONS

To prevent possible connecting problems between **OBI N8** board and the external systems, the User has to read carefully the information of the previous paragraphs and he must follow these instructions:

- To connect to the optocoupled input signals, only the contacts to acquire must be connected from the external system(s). These contacts (relays, switches, etc.) must connect or not connect the input signal INx to GND opto. About the correspondance between logic signals and contact status, an open contact generates a logic **1**, a closed contact generates a logic **0**, following the NPN standard.
- The TTL output signals can be connected directly only to a device featuring the same type of interface. About the correspondance between logic signals and TTL output status, remember that a logic **0** generates a TTL 0 Vdc, while a logic **1** generates a TTL +5 Vdc.

OBI P8

OBI P8 (Optocoupled Block 8 Input PNP) is a **BLOCK** serie module designed to manage and visualize 8 optocoupled inputs, PNP type, by 8 TTL digital signals.

The 8 input TTL and the +5Vdc needed to supply the digital section, are available through a standard 20 pins I/O **ABACO**® connector, allowing to interface to the several **grifo**® cards, like **GPC**® **F2**, **GPC**® **51**, **GPC**® **552**, **GPC**® **011**, **GPC**® **188**, **PIO 01**, **IAC 01**, etc.

The 8 optocoupled inputs are available on a 10 pins quick release screw terminal connector, that allows to interface promptly to the external world.

Through this same connector it is also possible to supply the input optocouplers section, this supply tension can vary in the range +12÷+24 Vdc.

The board features 8 yellow LEDs that provide the User a visual feed back about the status of the 8 signals available on the module.

OBI P8 is delivered with a plastic mount for DIN 46277-1 and DIN 46277-3 rails.

TECHNICAL FEATURES

N. of PNP optocoupled input lines:	8
N. of TTL signals:	8
Size:	70 x 80 x 40 mm
Weight:	120 g
Connectors:	CN1 vertical low profile M 20 pins CN2 quick release screw terminal 10 pins
Temperature range:	from 0 to 50 centigrad dereeses
Relative humidity:	20% up to 90% without condense
Buffer power supply:	+5 Vdc
NPN optocoupled input section power supply tension:	in the range +12 ÷ +24 Vdc
Current consumption on +5 Vdc:	70 mA max

CN1 - I/O ABACO® CONNECTOR

CN1 is a 20 pins low profile male connector, featuring standard I/O ABACO® pin out, where 16 digital I/O TTL signals are available, divided in two ports.

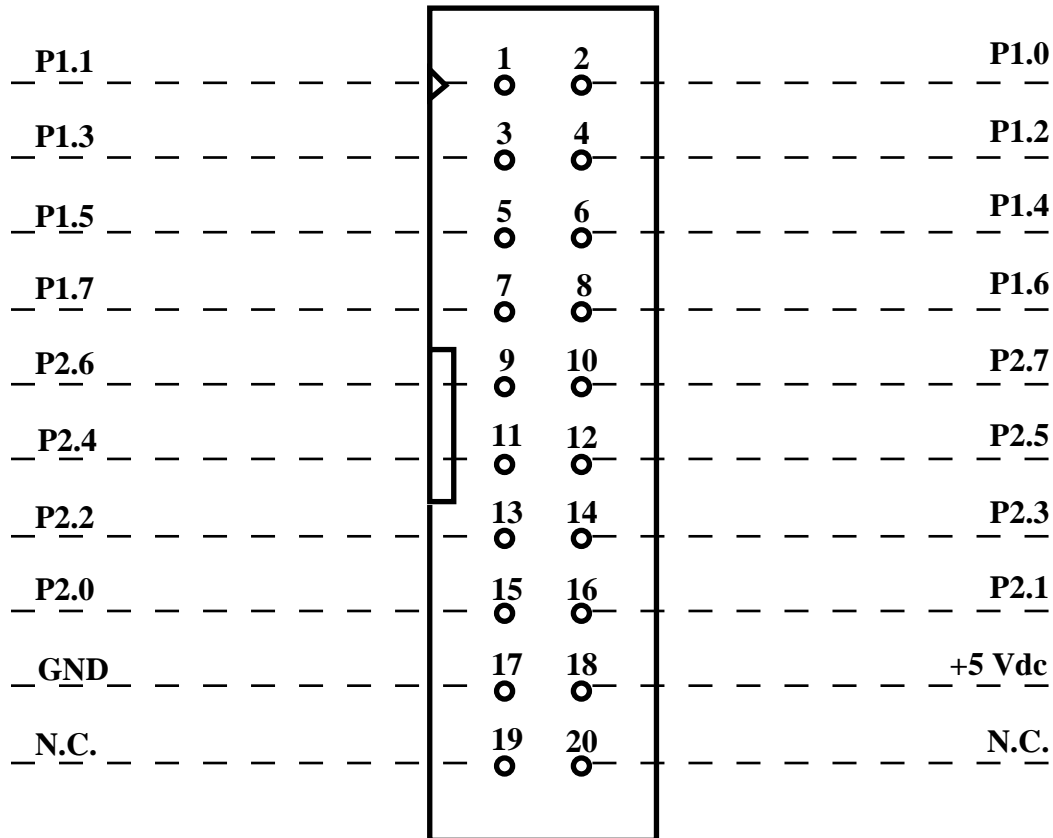

FIGURE 8: CN1 - I/O ABACO® CONNECTOR

Signals description:

P1.n	=	I/O - n-th signals of port 1.
P2.n	=	I/O - n-th signals of port 2.
+5 Vdc	=	I/O - Power supply +5 Vdc.
GND	=	- Ground.
N.C.	=	- Not connected.

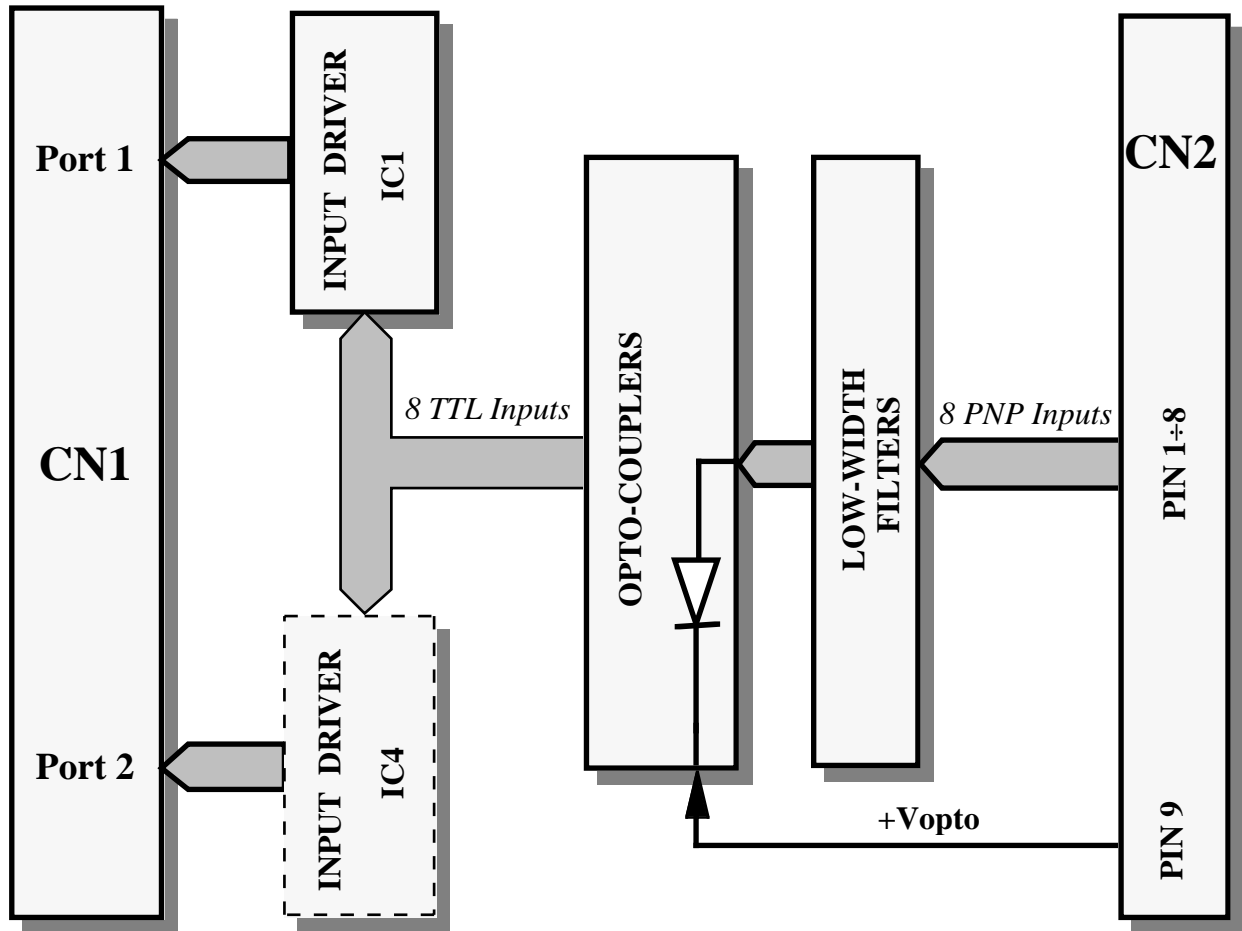

FIGURE 9: OBI P8 BLOCK DIAGRAM

CN2 - INPUT CONNECTOR

CN2 is a 10 pins quick release screw terminal connector, used to connect the 8 PNP optocoupled inputs and the external world.

The following figure refers to a view of the connector from the component side.

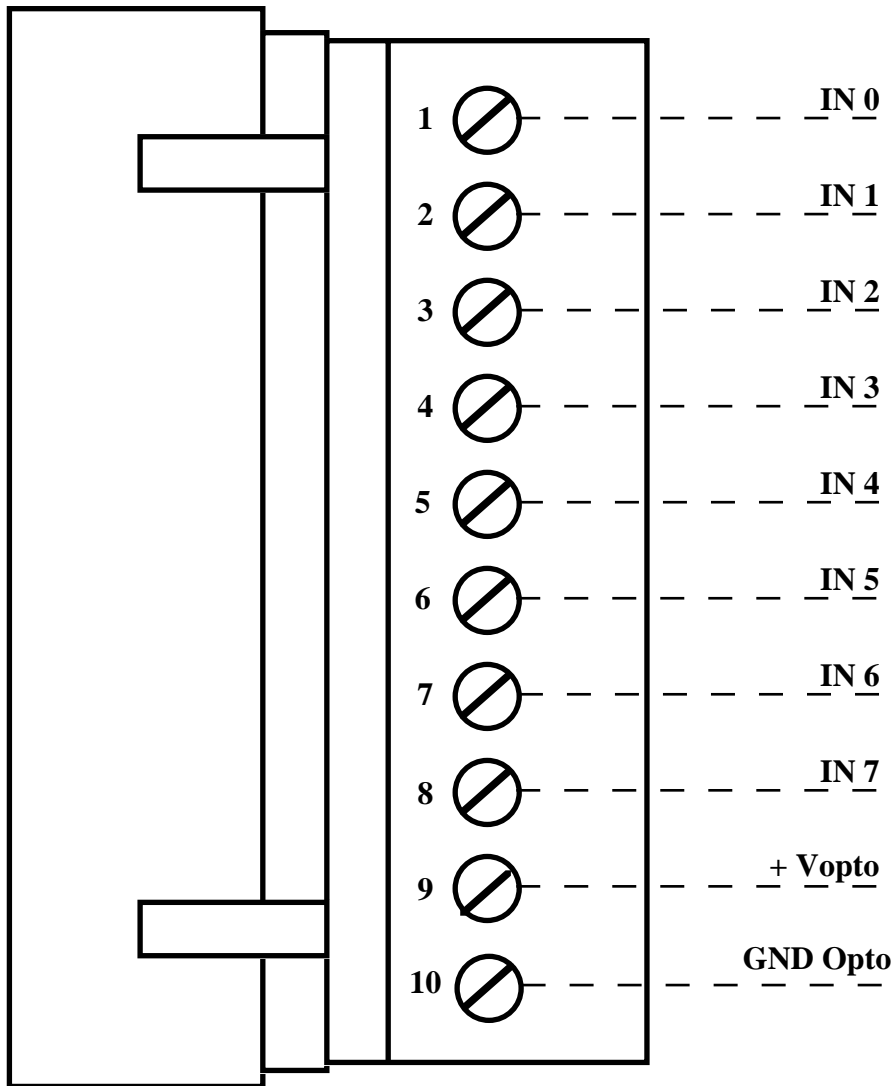

FIGURE 10: CN2 - INPUT CONNECTOR

Signals description:

- IN n** = I - n-th PNP input corresponding to signal P?.n on connector CN1
- +Vopto** = I - Power supply of optocoupled PNP input section i range 12÷24 Vdc.
- GND Opto** = - Ground signal for PNP optocoupled inputs.

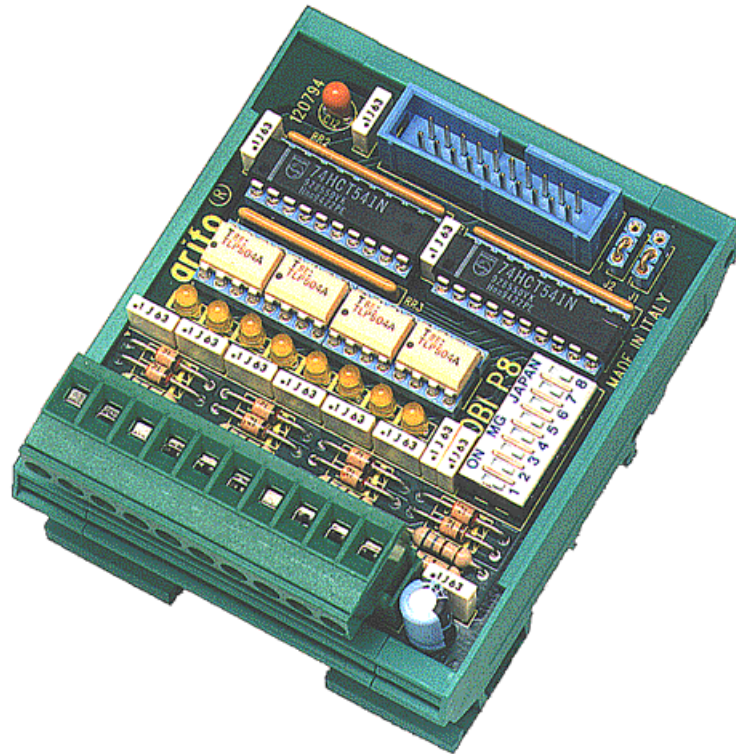

FIGURE 11: OBI P8 CARD PHOTO

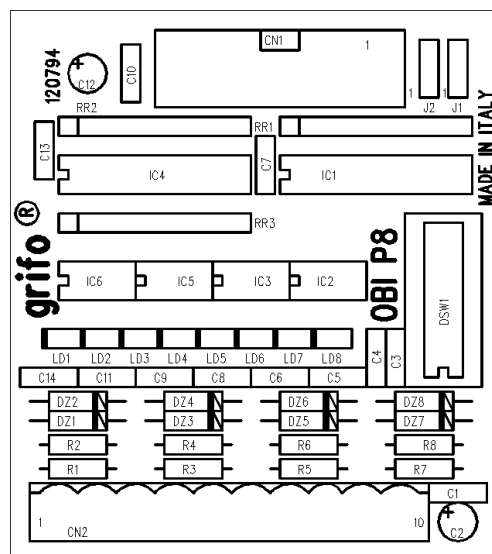

FIGURE 12: OBI P8 COMPONENTS MAP

HARDWARE DESCRIPTION

OBI P8 can interface both port 1 and port 2 available on the 20 pins connector simply moving the buffer 74HCT541 from socket IC1 to socket IC4. When the buffer is installed on **IC1**, the 8 optocoupled PNP input signals can be fetched from **port 1** and viceversa when such component is installed on **IC4**, the inputs are interfaced to **port 2**. The choice of which port to use can be done by the User according to his/her specific needs, being careful not to create electric conflicts when many modules of this family are installed at the same time.

The power to supply the input optocouplers must be provided between pin 9 and 10 of input connector CN2; this supply tension must be in the range from +12 Vdc to +24 Vdc.

ON BOARD JUMPERS

On **OBI P8** module two 3 pins Jumpers, called **J1** and **J2**, are installed. They allow to connect the signals of Port 1 and 2 of CN1 to PULL-UP or PULL-DOWN resistors; in detail the description of these jumpers is the following:

- J1** pos. 1-2: Connects signals of Port 1 to 8 PULL-UP resistors
pos. 2-3: Connects signals of Port 1 to 8 PULL-DOWN resistors
- J2** pos. 1-2: Connects signals of Port 2 to 8 PULL-UP resistors
pos. 2-3: Connects signals of Port 2 to 8 PULL-DOWN resistors

The port used by **OBI P8** to deliver the signals must be connected to PULL-UP resistors, so if the module uses port 1 (74HCT541 installed on IC1), jumper J1 must be in position 1-2; viceversa if the module **OBI P8** uses port 2 (74HCT541 installed on IC4), jumper J2 must be in position 1-2.

The port not used must be configured according the boards that are going to be connected to it; in particular if it will be connected to boards featuring Output signals (**RBO 01**, **RBO 08**, **TBO 08**, **XBI T4**, **XBI R4**, etc.), the corresponding Jumper will have to be in position 2-3, if it will be connected to boards featuring Input signals (another **OBI P8**, **OBI N8**, etc.), the Jumper will have to be in position 1-2.

VISUALIZATIONS

OBI P8 module is provided with eight signalation LEDs to show status information about its signals, as described in the following table:

LEDs	COLOUR	PURPOSE
LD1÷LD8	Yellow	Visualize the status of the eight optocoupled input signals, respectively IN0÷IN7. A LED on indicates the input contact is connected to +Vopto.

FIGURE 13: OBI P8 LEDS TABLE

SOFTWARE DESCRIPTION

The 8 PNP optocoupled inputs available on **OBI P8**, are acquired directly from the bits 0÷7 of the selected port; in detail the correspondance between bit and input is the following:

Port ?.0	->	IN0
Port ?.1	->	IN1
Port ?.2	->	IN2
Port ?.3	->	IN3
Port ?.4	->	IN4
Port ?.5	->	IN5
Port ?.6	->	IN6
Port ?.7	->	IN7

Where ? indicates port 1 or 2, according to which socket the component 74HCT541 is installed on, as previously described.

The correspondance between logic status of bits and signals status is the following:

Bit at logic 0	->	Input activated	=	Input contact connected to GND opto
Bit at logic 1	->	Input not activated	=	Input contact not connected

I/O CONNECTIONS

To prevent possible connecting problems between **OBI P8** board and the external systems, the User has to read carefully the information of the previous paragraphs and he must follow these instructions:

- To connect to the optocoupled input signals, only the contacts to acquire must be connected from the external system(s). These contacts (relays, switches, etc.) must connect or not connect the input signal INx to +V opto. About the correspondance between logic signals and contact status, an open contact generates a logic **1**, a closed contact generates a logic **0**.
- The TTL output signals can be connected directly only to a device featuring the same type of interface. About the correspondance between logic signals and TTL output status, remember that a logic **0** generates a TTL 0 Vdc, while a logic **1** generates a TTL +5 Vdc.

RBO 08

RBO 08 (Relays Block Output 8 lines) is a **BLOCK** serie module designed to manage and visualize 8 normally open 3A relay outputs, by 8 TTL digital signals. The 8 input TTL are available through a standard 20 pins I/O **ABACO**® connector, allowing to interface to the several **grifo**® cards, like **GPC**® F2, **GPC**® 51, **GPC**® 552, **GPC**® 011, **GPC**® 188, **PIO 01**, **IAC 01**, etc. The 8 relays 3A outputs are available on an 11 pins quick release screw terminal connector, that allows to interface promptly to the external world. Remarkable and efficient is the protection offered by MOV, put in parallel connection with the output contacts, they are able to suppress nominal +39 Vdc transients that occur when a commutation happens on reactive loads supplied by 24 Vac. Another remarkable feature of this module is the possibility to supply the relays by +12 Vdc or +24 Vdc, the choice can be made through a jumper installed on the board that configures the relays section for being supplied by one of these two tensions. The board features 8 red LEDs that provide the User a visual feed back about the status of the 8 signals available on the module **RBO 08**. **RBO 08** is delivered with a plastic mount for DIN 46277-1 and DIN 46277-3 rails.

TECHNICAL FEATURES

N. of TTL input lines:	8
N. of output lines:	8 with normally open 3 A relays
Size:	70 x 80 x 40 mm
Weight:	180 g
Connectors:	CN1 quick release screw terminal connector 2 pins CN2 vertical low profile male 20 pins CN3 quick release screw terminal connector 11 pins
Temperature range:	from 0 to 50 centigrad degrees
Relative humidity:	20% up to 90% without condense
Max tension on outputs (+Vload):	24 Vac / 24 Vdc Please contact grifo ® if You need to connect an higher voltage
Max current on outputs:	3 A
Buffer power supply:	+5 Vdc
Relays supply voltage:	Selectable between +12 Vdc or +24 Vdc
Current consumption on +5 Vdc:	10 mA max
Current consumption on +12/+24 Vdc:	170 mA max

CN2 - I/O ABACO® CONNECTOR

CN2 is a 20 pins low profile male connector, featuring standard I/O ABACO® pin out, where 16 digital I/O TTL signals are available, divided in two ports.

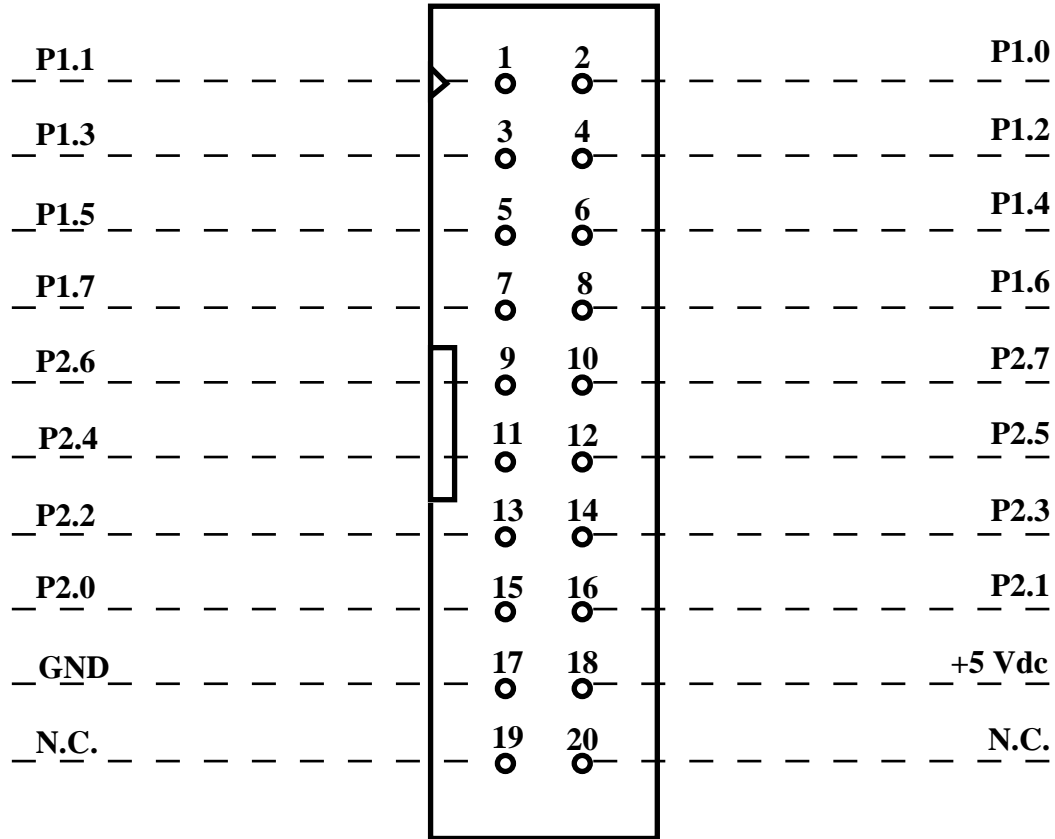

FIGURE 15: CN2 - I/O ABACO® CONNECTOR

Signals description:

P1.n	=	I/O - n-th signals of port 1.
P2.n	=	I/O - n-th signals of port 2.
+5 Vdc	=	I/O - Power supply +5 Vdc.
GND	=	- Ground.
N.C.	=	- Not connected.

CN1 - RELAYS SUPPLY CONNECTOR

CN1 is a 2 pins quick release screw terminal connector, it provides power supply for the relays section, its pin out is made as follows:

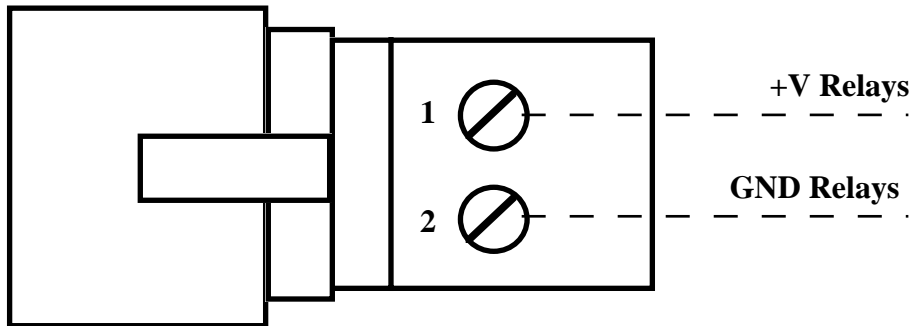

FIGURE 16: CN1 - RELAYS SUPPLY CONNECTOR

Signals description:

- +V Relays** = I - Power supply for relays section: +12 Vdc or +24 Vdc
- GND Relays** = - Ground for relays section.

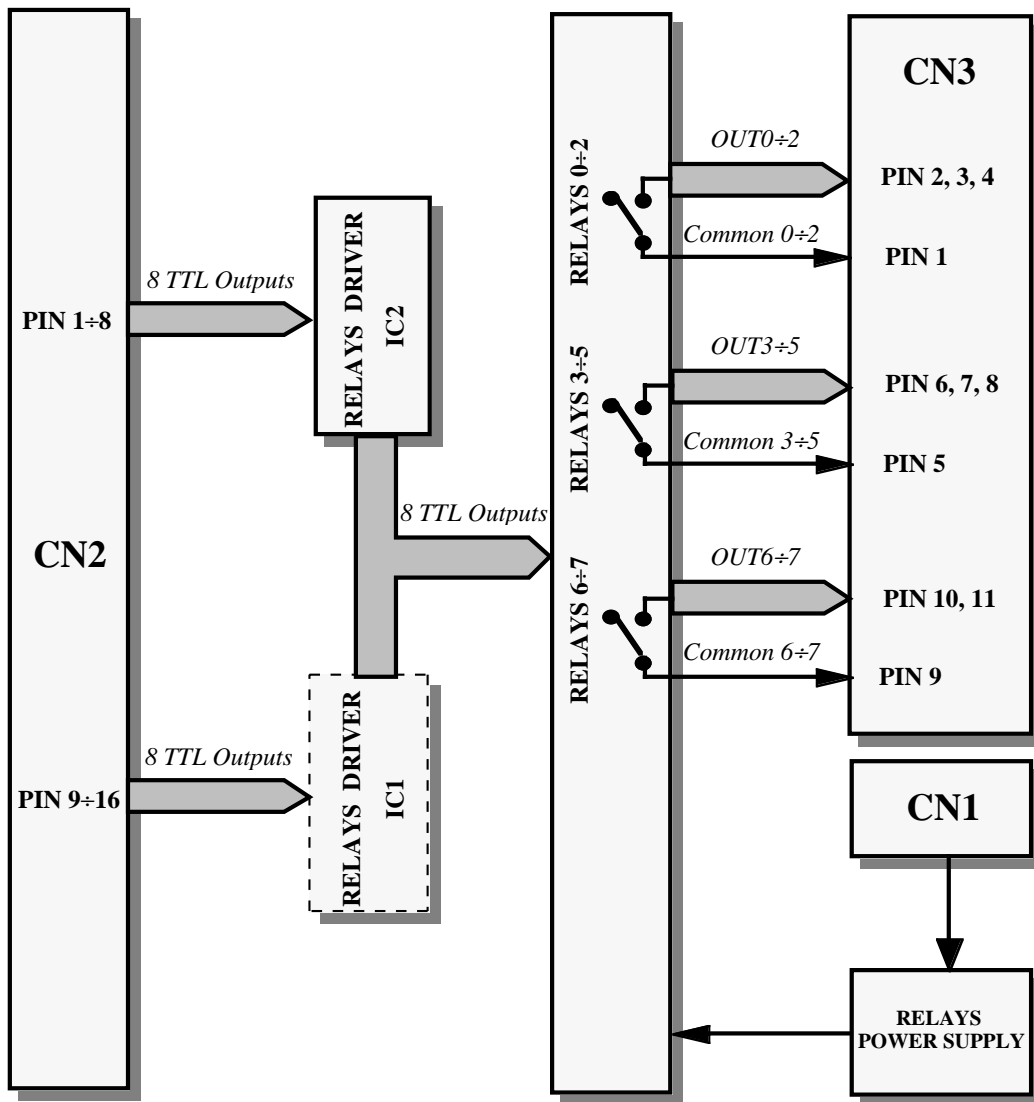

FIGURE 17: RBO 08 BLOCK DIAGRAM

CN3 - OUTPUT CONNECTOR

CN3 is an 11 pins quick release screw terminal connector, used to connect the 8 output relays and the corresponding bits on the selected port.

The following figure refers to a view of the connector from the component side.

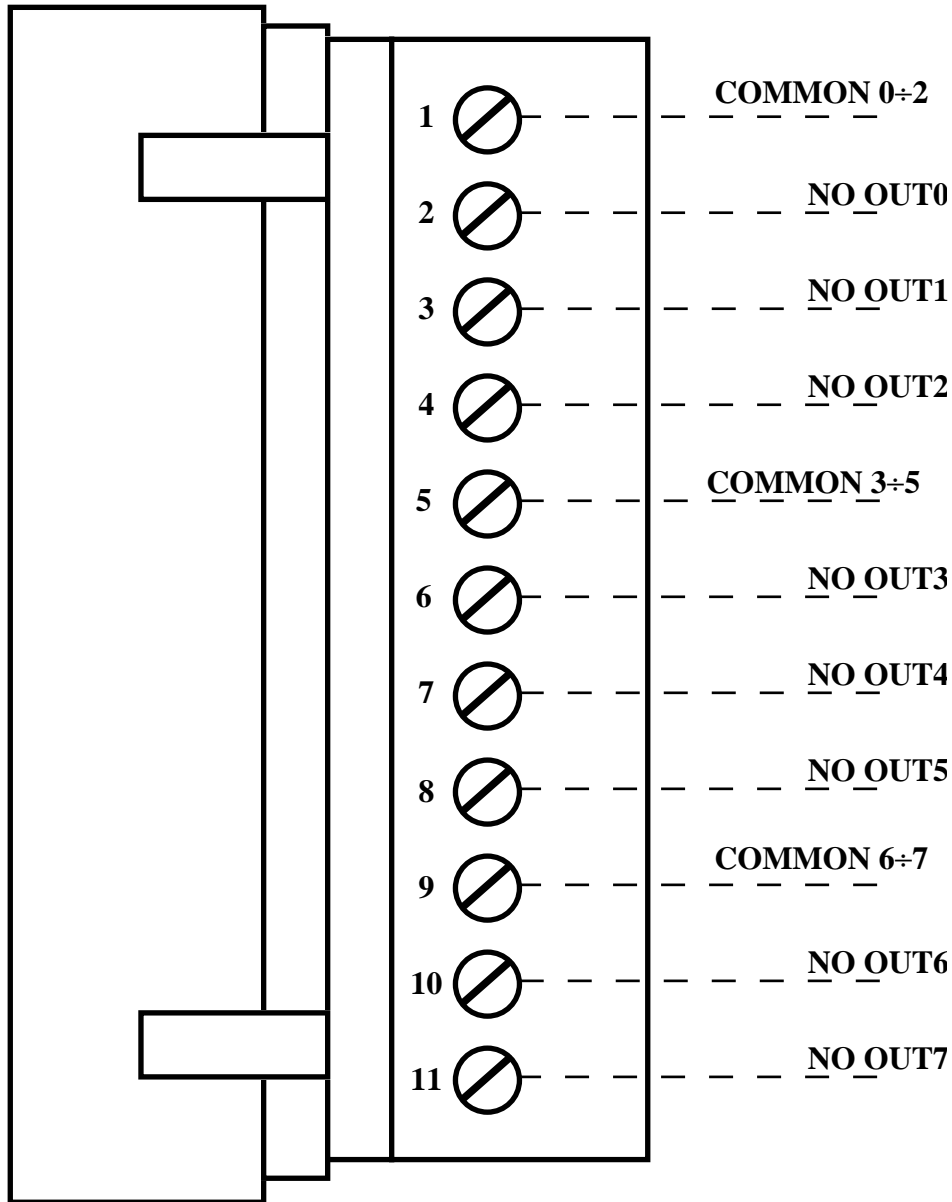

FIGURE 18: CN3 - OUTPUT CONNECTOR

Signals description:

- COMMON 0÷2** = - Common contact for the relays of outputs NO OUT0÷2.
- COMMON 3÷5** = - Common contact for the relays of outputs NO OUT3÷5.
- COMMON 6÷7** = - Common contact for the relays of outputs NO OUT6÷7.
- NO OUTn** = - Normally open contact of n-th relay output.

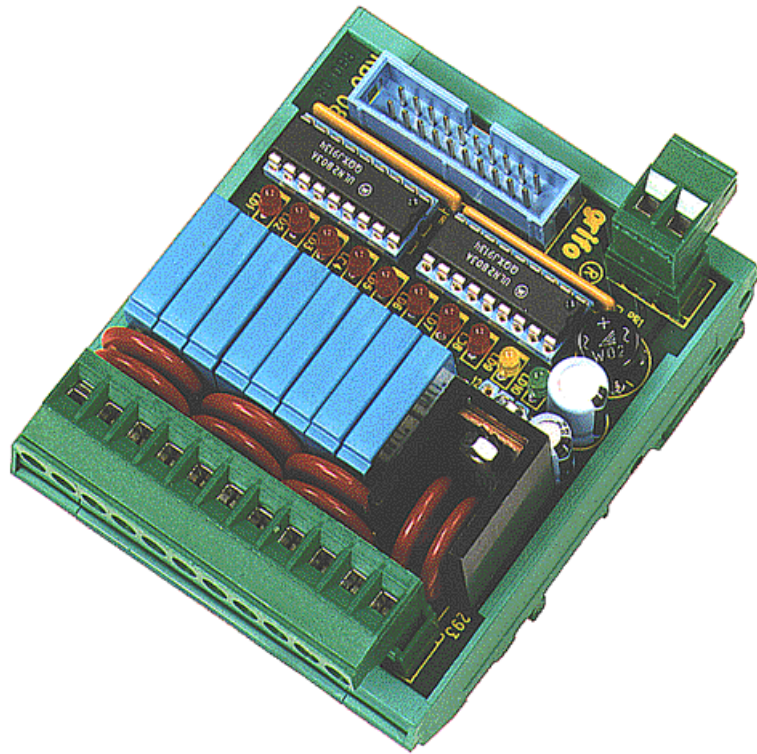

FIGURE 19: RBO 08 CARD PHOTO

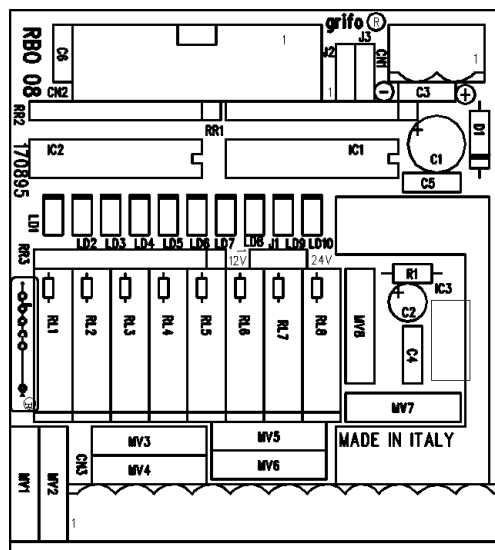

FIGURE 20: RBO 08 COMPONENTS MAP

HARDWARE DESCRIPTION

RBO 08 can interface both port 1 and port 2 available on the 20 pins connector simply moving the buffer ULN 2803 from socket IC1 to socket IC2. When the buffer is installed on **IC1**, the 8 output signals are fetched from **port 2** and viceversa when such component is installed on **IC2**, the outputs are fetched from **port 1**. The choice of which port to use can be performed by the User according to his/her specific needs, being careful not to create electric conflicts when many modules of this family are installed at the same time.

Remarkable and efficient is the protection offered by MOV, put in parallel connection with the output contacts, they are able to suppress nominal +39 Vdc transients that occur when a commutation happens on reactive loads supplied by 24 Vac. In fact, when an inductor is removed its power supply, it discharges all the energy previously stored in its magnetic field, creating so a transient that risks to damage the devices connected.

ON BOARD JUMPERS

On **RBO 08** module three 3 pins Jumpers are installed. Jumper **J1** allows to configure the relays section to be supplied by a tension of +12 Vdc or +24 Vdc. Jumpers **J2** and **J3** allow to connect the signals of Port 1 and 2 of CN1 to PULL-UP or PULL-DOWN resistors; in detail the description of these jumpers is the following:

- | | | |
|-----------|-----------|---|
| J1 | pos. 1-2 | Configures the relays section to be supplied by +12 Vdc |
| | pos. 2-3 | Configures the relays section to be supplied by +24 Vdc |
| J2 | pos. 1-2: | Connects signals of Port 1 to 8 PULL-UP resistors |
| | pos. 2-3: | Connects signals of Port 1 to 8 PULL-DOWN resistors |
| J3 | pos. 1-2: | Connects signals of Port 2 to 8 PULL-UP resistors |
| | pos. 2-3: | Connects signals of Port 2 to 8 PULL-DOWN resistors |

The port used by **RBO 08** to deliver the signals must be connected to PULL-DOWN resistors, so if the module uses port 1 (ULN 2803 installed on IC2), jumper J2 must be in position 2-3; viceversa if the module **RBO 08** uses port 2 (ULN 2803 installed on IC1), jumper J3 must be in position 2-3. The port not used must be configured according to the boards that are going to be connected to it; in particular if it will be connected to boards featuring Output signals (**RBO 01**, another **RBO 08**, **TBO 08**, **XBI T4**, **XBI R4**, etc.), the corresponding Jumper will have to be in position 2-3, if it will be connected to boards featuring Input signals (**OBI P8**, **OBI N8**, etc.), the Jumper will have to be in position 1-2.

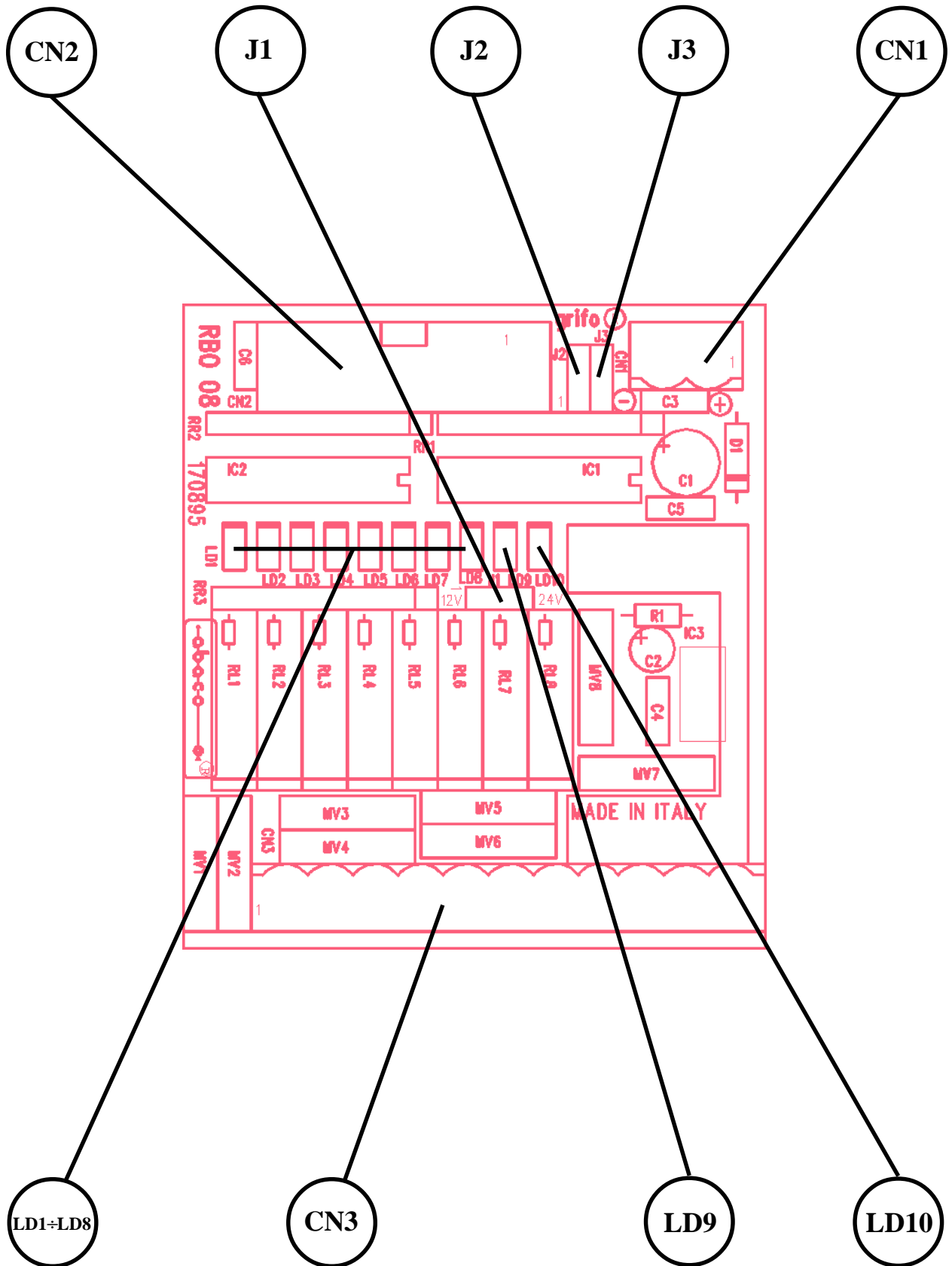

FIGURE 21: RBO 08 JUMPERS, CONNECTORS, LEDS ETC. LOCATION

VISUALIZATIONS

RBO 08 module is provided with eight signalation LEDs to show status information about its signals, as described in the following table:

LEDs	COLOUR	PURPOSE
LD1÷LD8	Red	Visualize the status of the eight relay outputs, respectively called NO OUT0÷NO OUT7. A LED on indicates an active output (relay contact closed).

FIGURE 22: RBO 08 LEDS TABLE

The module features also two more LEDs, LD9 yellow and LD10 green, that respectively indicate whether the relays section is supplied by +12 Vdc or +24 Vdc. In detail the correspondance is:

LD9 on, LD10 off	->	Relays section supplied by +12 Vdc (Jumper J1 in position 1-2)
LD9 and LD10 on	->	Relays section supplied by +24 Vdc (Jumper J1 in position 2-3)

SOFTWARE DESCRIPTION

The 8 relays outputs available on **RBO 08**, are managed directly through the bits 0÷7 of the selected port; in detail the correspondance between bit and input is the following:

Port ?.0	->	NO OUT0
Port ?.1	->	NO OUT1
Port ?.2	->	NO OUT2
Port ?.3	->	NO OUT3
Port ?.4	->	NO OUT4
Port ?.5	->	NO OUT5
Port ?.6	->	NO OUT6
Port ?.7	->	NO OUT7

Where ? indicates port 1 or 2, according to which socket the component ULN 2803 is installed on, as previously described.

The correspondance between logic status of bits and signals status is the following:

Bit at logic 0	->	Output not actived	= Relay contact open
Bit at logic 1	->	Output actived	= Relay contact closed

I/O CONNECTIONS

To prevent possible connecting problems between **RBO 08** board and the external systems, the User has to read carefully the information of the previous paragraphs and he must follow these instructions:

- The relays output signals must be connected directly to the load to drive (power relays, etc.). The board provides the normally open contacts called NO OUT x, capable to bear a maximum current of **3 A** with a tension that can be **24 Vdc** or **24 Vac**.

To allow the User to drive several loads having different power supplies, each output section is provided with three different COMMON terminals connected to three groups of three, three, and two relays.

NOTE: Should the User connect to the relays a voltage higher to the one declared in this manual, please contact **grifo®** directly; in fact this implies a different hardware configuration that must be performed by **grifo®** technicians.

- The TTL output signals can be connected directly only to a device featuring the same type of interface. About the correspondance between logic signals and TTL output status, remember that a logic **0** generates a TTL 0 Vdc, while a logic **1** generates a TTL +5 Vdc.

RBO 16

RBO 16 (Relays Block Output 16 lines) is a **BLOCK** serie module designed to manage and visualize 16 normally open 3A relay outputs, by 16 TTL digital signals. The 16 input TTL are available through a standard 20 pins I/O **ABACO**[®] connector, allowing to interface to the several **grifo**[®] cards, like **GPC[®] F2**, **GPC[®] 51**, **GPC[®] 552**, **GPC[®] 011**, **GPC[®] 188**, **PIO 01**, **IAC 01**, etc. The 16 relays 3A outputs are available on two comfortable 11 pins quick release screw terminal connector, that allows to interface promptly to the external world. Remarkable and efficient is the protection offered by MOV, put in parallel connection with the output contacts, they are able to suppress nominal +39 Vdc transients that occur when a commutation happens on reactive loads supplied by 24 Vac. Another remarkable feature of this module is the possibility to supply the relays by +12 Vdc or +24 Vdc, the choice can be made through a jumper installed on the board that configures the relays section for being supplied by one of these two tensions. The board features 16 red LEDs that provide the User a visual feed back about the status of the 16 signals available on the module **RBO 16**. **RBO 16** is delivered with a plastic mount for DIN 46277-1 and DIN 46277-3 rails.

TECHNICAL FEATURES

N. of TTL input lines:	16
N. of output lines:	16 with normally open 3 A relays
Size:	70 x 80 x 40 mm
Weight:	180 g
Connectors:	CN1 quick release screw terminal connector 2 pins CN2 vertical low profile male 20 pins CN3 quick release screw terminal connector 11 pins CN4 quick release screw terminal connector 11 pins
Temperature range:	from 0 to 50 centigrad degrees
Relative humidity:	20% up to 90% without condense
Max tension on outputs (+Vload):	24 Vac / 24 Vdc Please contact grifo [®] if You need to connect an higher voltage
Max current on outputs:	3 A
Buffer power supply:	+5 Vdc
Relays supply voltage:	Selectable between +12 Vdc or +24 Vdc
Current consumption on +5 Vdc:	30 mA max
Current consumption on +12/+24 Vdc:	320 mA max

CN2 - I/O ABACO® CONNECTOR

CN2 is a 20 pins low profile male connector, featuring standard I/O ABACO® pin out, where 16 digitaldi I/O TTL signals are available, divided in two ports.

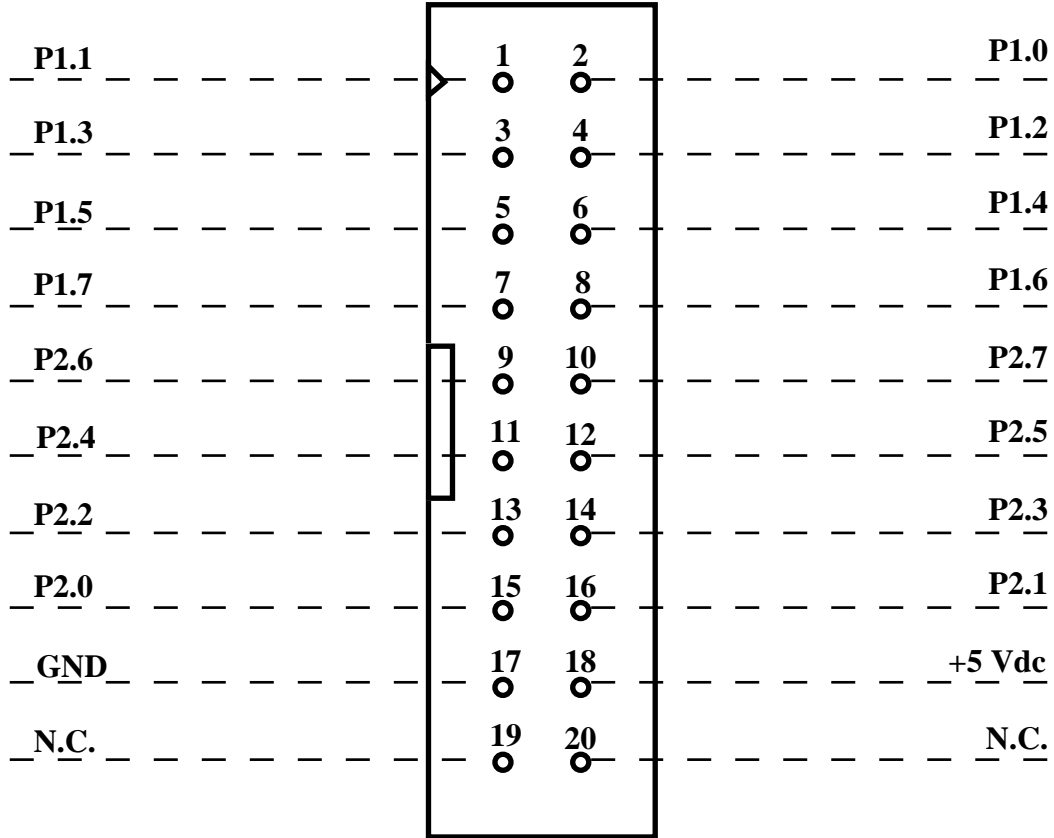

FIGURE 23: CN2 - I/O ABACO® CONNECTOR

Signals description:

- P1.n** = I/O - n-th signals of port 1.
- P2.n** = I/O - n-th signals of port 2.
- +5 Vdc** = I/O - Power supply +5 Vdc.
- GND** = - Ground.
- N.C.** = - Not connected.

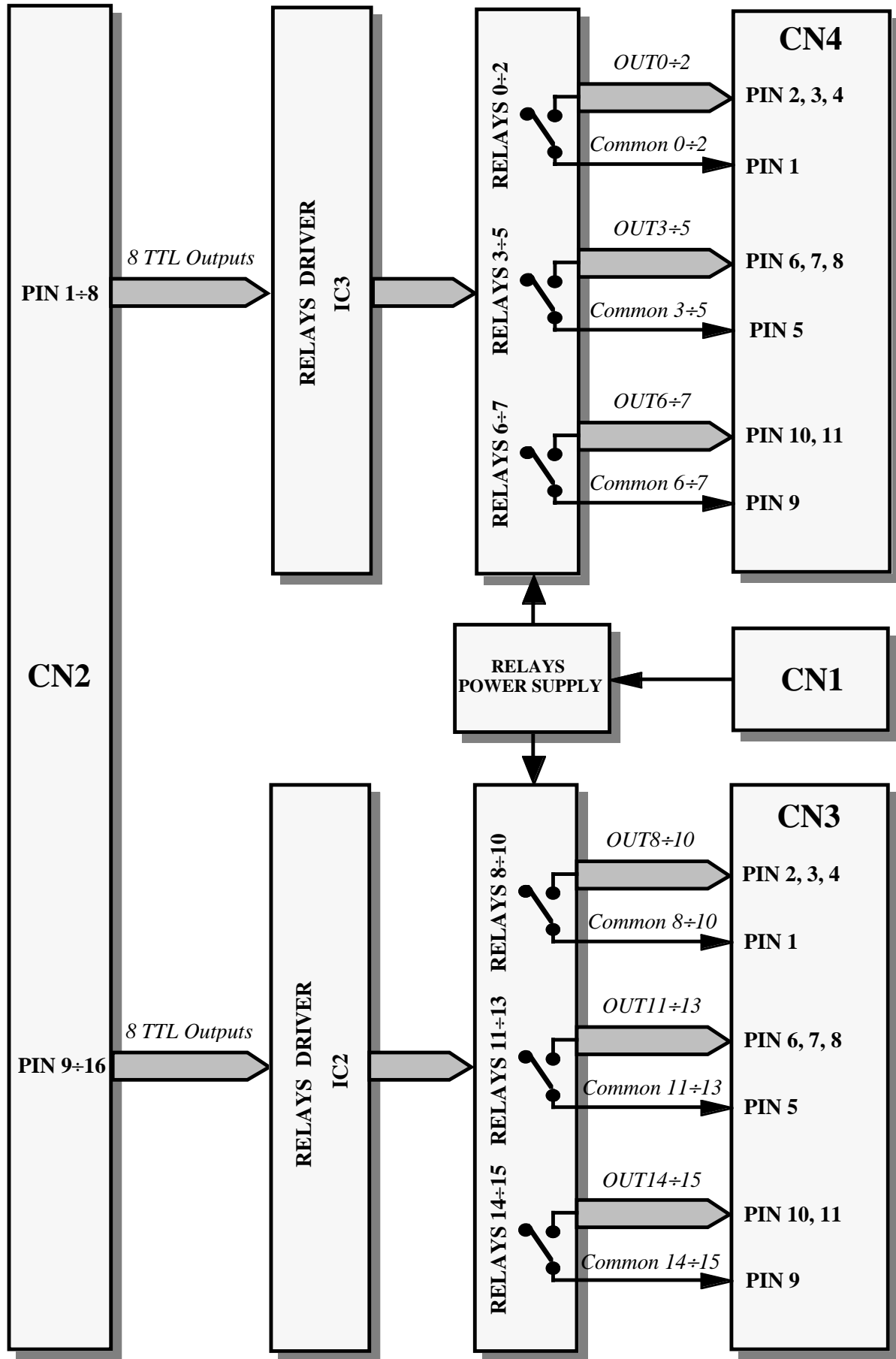

FIGURE 24: RBO 16 BLOCK DIAGRAM

CN3 - OUTPUTS 8÷15 CONNECTOR

CN3 is an 11 pins quick release screw terminal connector, used to connect the 8 output relays corresponding to bits of port 2 and the external world.

The following figure refers to a view of the connector from the component side.

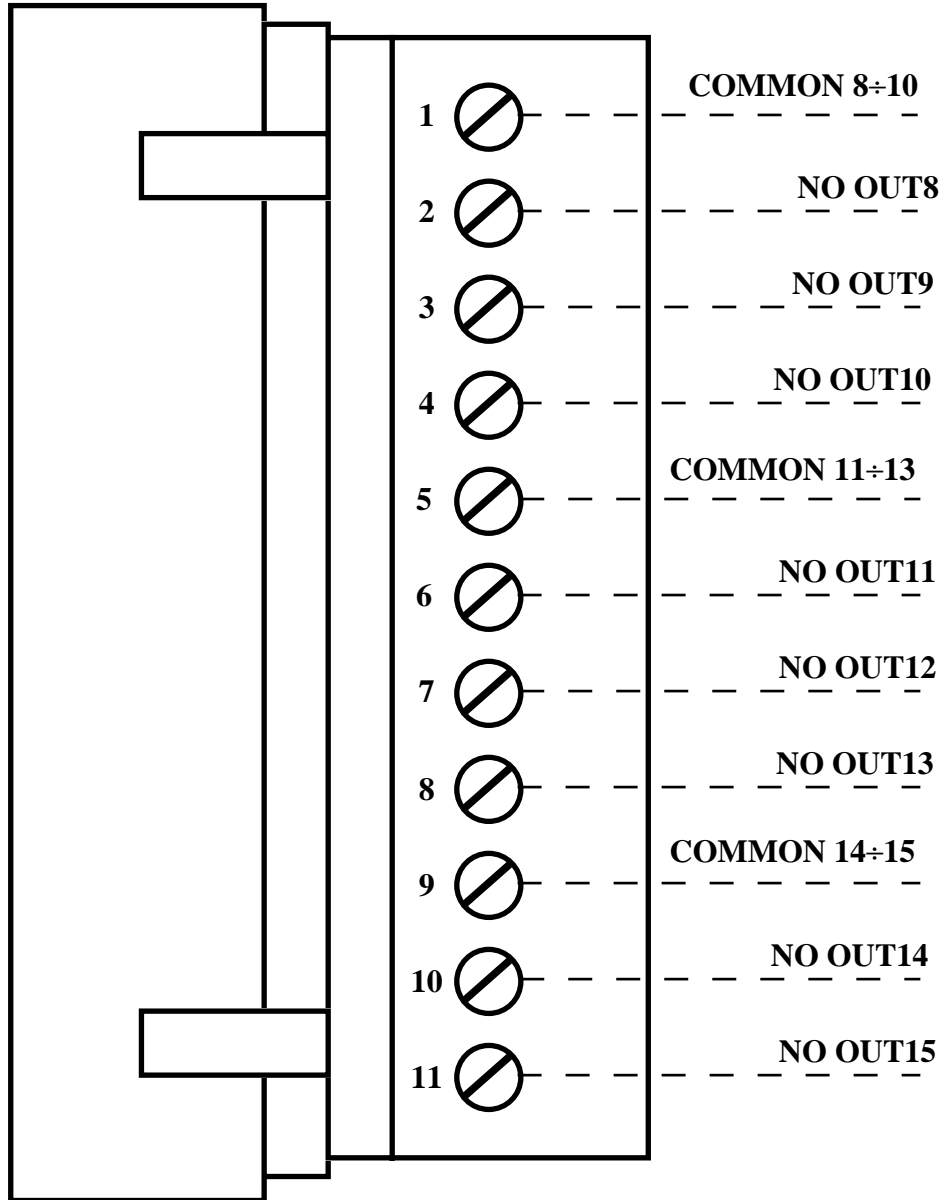

FIGURE 25: CN3 - OUTPUTS 8÷15 CONNECTOR

Signals description:

- COMMON 8÷10** = - Common contact for the relays of outputs NO OUT8÷10.
- COMMON 11÷13** = - Common contact for the relays of outputs NO OUT11÷13.
- COMMON 14÷15** = - Common contact for the relays of outputs NO OUT14÷15.
- NO OUTn** = - Normally open contact of n-th relay output.

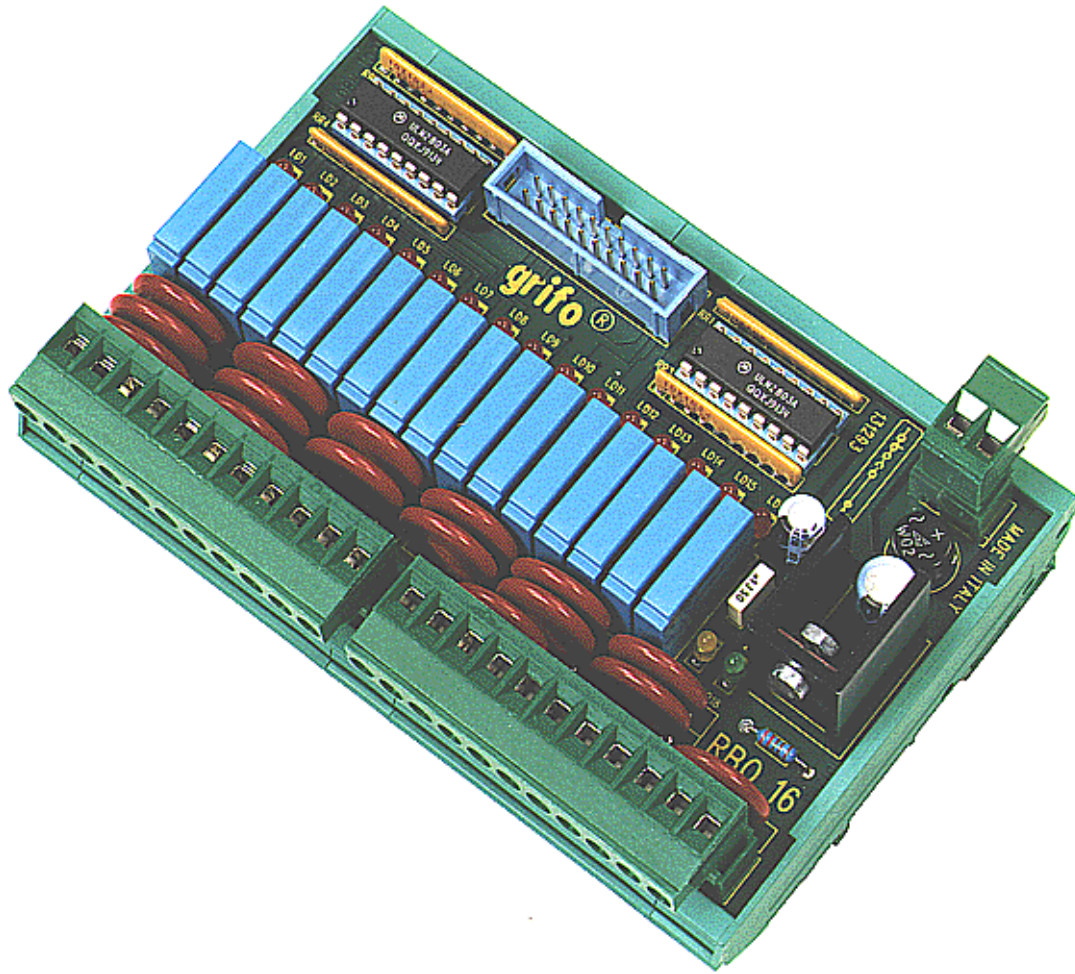

FIGURE 26: RBO 16 CARD PHOTO

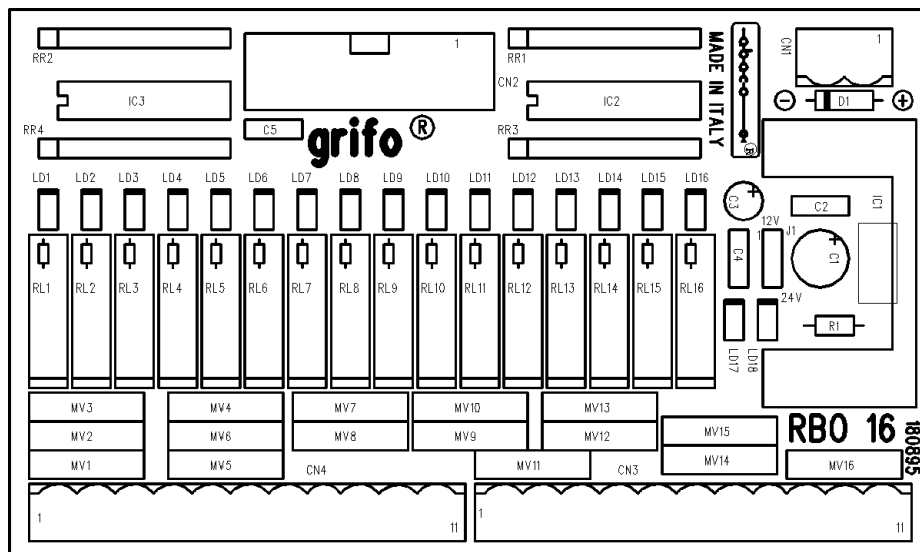

FIGURE 27: RBO 16 COMPONENTS MAP

CN4 - OUTPUTS 0÷7 CONNECTOR

CN3 is an 11 pins quick release screw terminal connector, used to connect the 8 output relays corresponding to bits of port 2 and the external world.

The following figure refers to a view of the connector from the component side.

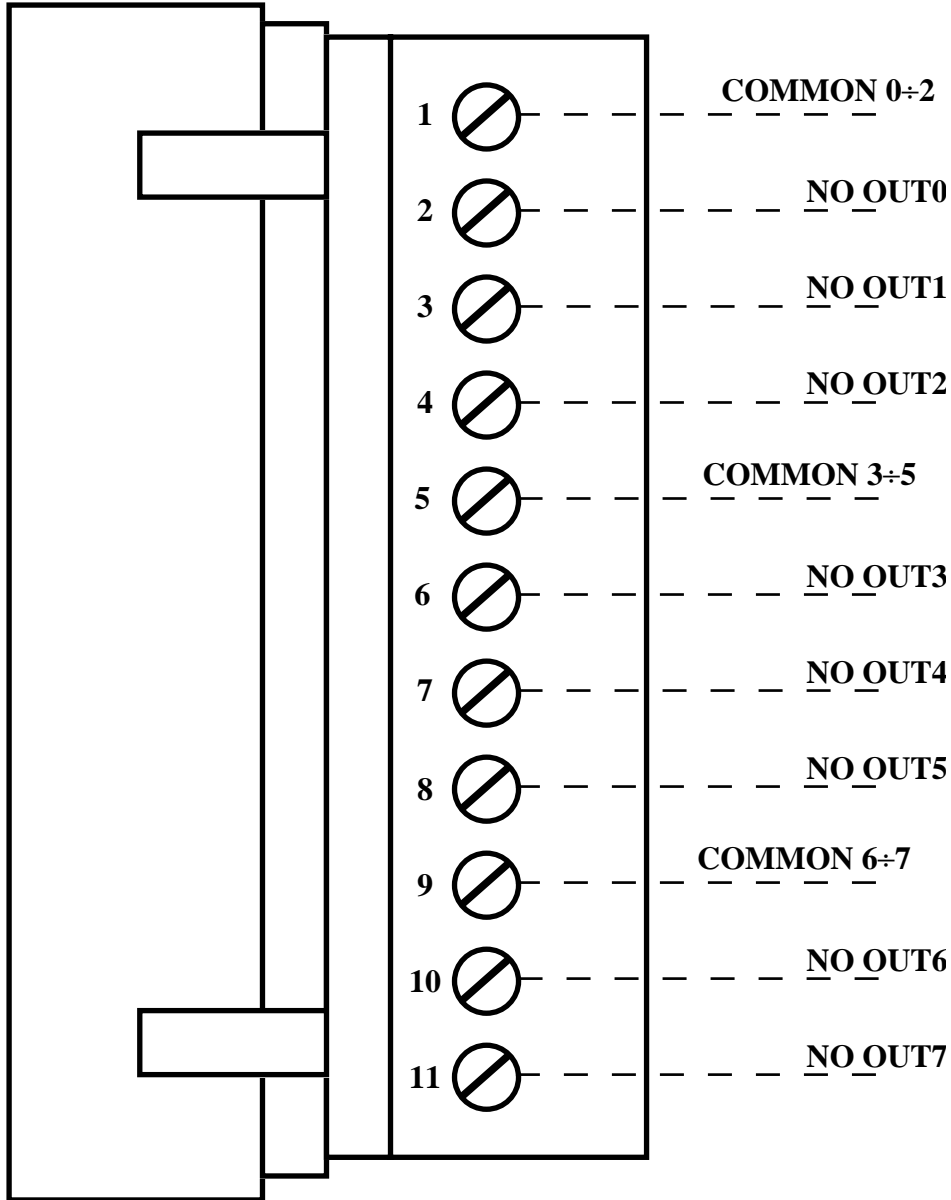

FIGURE 28: CN4 - OUTPUTS 0÷7 CONNECTOR

Signals description:

- COMMON 0÷2** = - Common contact for the relays of outputs NO OUT0÷2.
- COMMON 3÷5** = - Common contact for the relays of outputs NO OUT3÷5.
- COMMON 6÷7** = - Common contact for the relays of outputs NO OUT6÷7.
- NO OUTn** = - Normally open contact of n-th relay output.

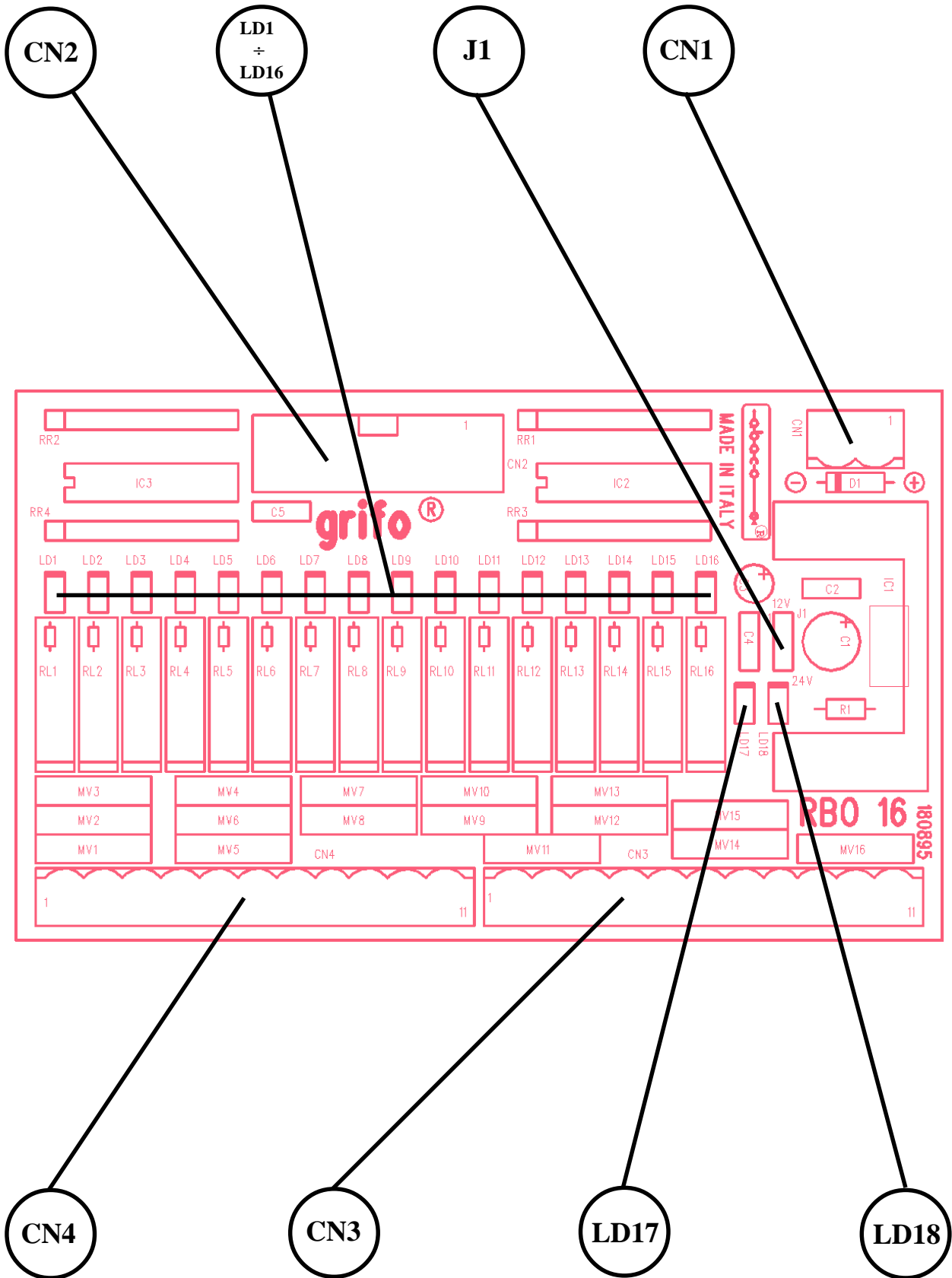

FIGURE 29: RBO 16 JUMPERS, CONNECTORS, LEDS ETC. LOCATION

CN1 - RELAYS SUPPLY CONNECTOR

CN1 is a 2 pins quick release screw terminal connector, it provides power supply for the relays section, its pin out is made as follows:

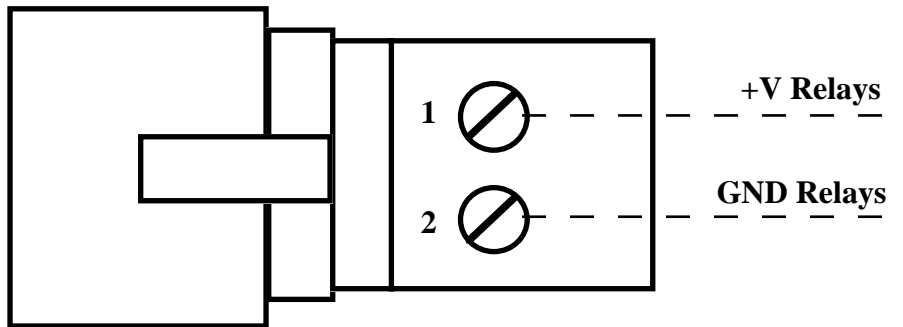

FIGURE 30: CN1 - RELAYS SUPPLY CONNECTOR

Signals description:

+V Relays	=	I	- Power supply for relays section: +12 Vdc or +24 Vdc
GND Relays	=		- Ground for relays section.

HARDWARE DESCRIPTION

RBO 16 can interface both port 1 and port 2 available on the 20 pins connector, in fact port 1 is used to manage outputs 0÷7, port 2 manages outputs 8÷15.

Remarkable and efficient is the protection offered by MOV, put in parallel connection with the output contacts, they are able to suppress nominal +39 Vdc transients that occur when a commutation happens on reactive loads supplied by 24 Vac. In fact, when an inductor is removed its power supply, it discharges all the energy previously stored in its magnetic field, creating so a transient that risks to damage the devices connected.

ON BOARD JUMPERS

On **RBO 16** module one 3 pins Jumper is installed. Jumper **J1** allows to configure the relays section to be supplied by a tension of +12 Vdc or +24 Vdc. In detail the description of the jumpers is the following:

J1	pos. 1-2	Configures the relays section to be supplied by +12 Vdc
	pos. 2-3	Configures the relays section to be supplied by +24 Vdc

VISUALIZATIONS

RBO 16 module is provided with sixteen signalation LEDs to show status information about its signals, as described in the following table:

LEDs	COLOUR	PURPOSE
LD1÷LD8	Red	Visualize the status of the eight relay outputs, respectively called NO OUT0÷NOOUT7. A LED on indicates an active output (relay contact closed).
LD9÷LD16	Red	Visualize the status of the eight relay outputs, respectively called NO OUT8÷NOOUT15. A LED on indicates an active output (relay contact closed).

FIGURE 31: RBO 16 LEDS TABLE

The module features also two more LEDs, LD17 yellow and LD18 green, that respectively indicate whether the relays section is supplied by +12 Vdc or +24 Vdc. In detail the correspondance is:

LD17on, LD18 off	->	Relays section supplied by +12 Vdc (Jumper J1 in position 1-2)
LD17 and LD18 on	->	Relays section supplied by +24 Vdc (Jumper J1 in position 2-3)

SOFTWARE DESCRIPTION

The 16 relays outputs available on **RBO 16**, are managed directly through the bits 0÷7 of port 1 and 2; in detail the correspondance between bit and input is the following:

Port 1.0	->	NO OUT0	Port 2.0	->	NO OUT8
Port 1.1	->	NO OUT1	Port 2.1	->	NO OUT9
Port 1.2	->	NO OUT2	Port 2.2	->	NO OUT10
Port 1.3	->	NO OUT3	Port 2.3	->	NO OUT11
Port 1.4	->	NO OUT4	Port 2.4	->	NO OUT12
Port 1.5	->	NO OUT5	Port 2.5	->	NO OUT13
Port 1.6	->	NO OUT6	Port 2.6	->	NO OUT14
Port 1.7	->	NO OUT7	Port 2.7	->	NO OUT15

The correspondance between logic status of bits and signals status is the following:

Bit at logic 0	->	Output not activated	= Relay contact open
Bit at logic 1	->	Output activated	= Relay contact closed

I/O CONNECTIONS

To prevent possible connecting problems between **RBO 16** board and the external systems, the User has to read carefully the information of the previous paragraphs and he must follow these instructions:

- The relays output signals must be connected directly to the load to drive (power relays, etc.). The board provides the normally open contacts called NO OUTx, capable to bear a maximum current of **3 A** with a tension that can be **24 Vdc** or **24 Vac**.

To allow the User to drive several loads having different power supplies, each output section is provided with three different COMMON terminals connected to six groups of three, three and two relays.

NOTE: Should the User connect to the relays a voltage higher to the one declared in this manual, please contact **grifo®** directly; in fact this implies a different hardware configuration that must be performed by **grifo®** technicians.

- The TTL output signals can be connected directly only to a device featuring the same type of interface. About the correspondance between logic signals and TTL output status, remember that a logic **0** generates a TTL 0 Vdc, while a logic **1** generates a TTL +5 Vdc.

TBO 08

TBO 08 (Transistor Block Output 8 lines) is a **BLOCK** serie module designed to manage 8 optocoupled and visualized open collector 3A transistor outputs, by 8 TTL digital signals. The 8 input TTL and the +5 Vdc needed to supply the optocouplers section are available through a standard 20 pins I/O **ABACO**® connector, allowing to interface to the several **grifo**® cards: **GPC**® **F2**, **GPC**® **51**, **GPC**® **552**, **GPC**® **011**, **GPC**® **188**, **PIO 01**, **IAC 01**, etc. The 8 relays 3A outputs are available on a comfortable 12 pins quick release screw terminal connector, that allows to interface promptly to the external world. Remarkable and efficient is the protection offered by back EMF diodes on the power transistors, especially useful in case of inductive loads. The board features 8 red LEDs that provide the User a visual feed back about the status of the 16 signals available on the module **TBO 08**. **TBO 08** is delivered with a plastic mount for DIN 46277-1 and DIN 46277-3 rails.

TECHNICAL FEATURES

N. of TTL input lines:	8
N. of output lines:	8 da 3 A in open collector
Size:	70 x 80 x 40 mm
Weight:	120 g
Connectors:	CN1 vertical low profile male 20 pins CN2 quick release screw terminal connector 12 pins
Temperature range:	from 0 to 50 centigrad degrees
Relative humidity:	20% up to 90% without condense
Power supply voltage:	+5 Vdc
Max tension on outputs (+Vload):	+45 Vdc
Max current on outputs:	3 A non continuative (*) 600 mA continuative, supplying a resistive load at +24 Vdc
Max power dissipated by transistor without heat sink:	1.25 W (*)
Current consumption on +5 Vdc:	100 mA max (*)

For further information about driver BD 675A, please refer to data book "Discrete Power Device" by SGS THOMSON or equivalent.

(*) Values referred to a working temperature of 20 °C

CN1 - I/O ABACO® CONNECTOR

CN1 is a 20 pins low profile male connector, featuring standard I/O ABACO® pin out, where 16 digitaldi I/O TTL signals are available, divided in two ports.

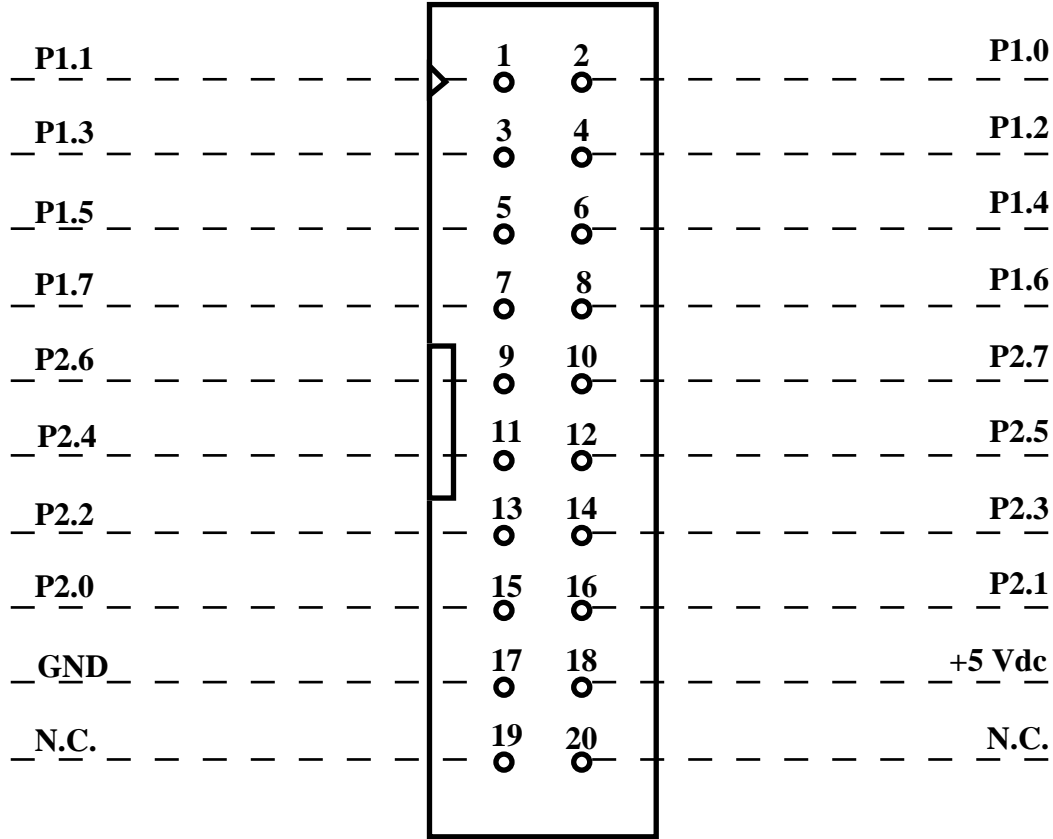

FIGURE 32: CN1 - I/O ABACO® CONNECTOR

Signals description:

- P1.n** = I/O - n-th signals of port 1.
- P2.n** = I/O - n-th signals of port 2.
- +5 Vdc** = I/O - Power supply +5 Vdc.
- GND** = - Ground.
- N.C.** = - Not connected.

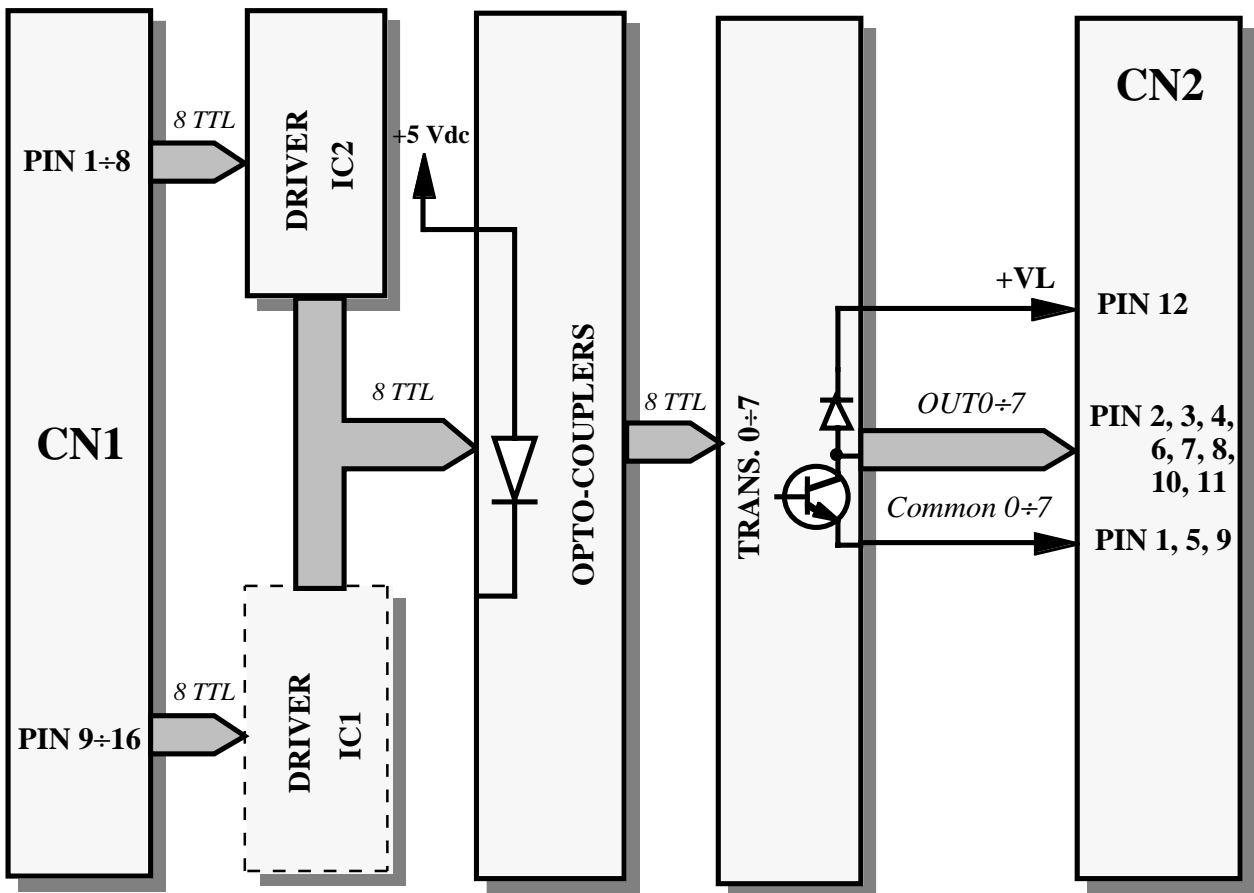

FIGURE 33: TBO 08 BLOCK DIAGRAM

CN2 - OUTPUT CONNECTOR

CN2 is a 12 pins quick release screw terminal connector, used to connect the 8 output power transistor corresponding to bits of selected port and the external world.

The following figure refers to a view of the connector from the component side.

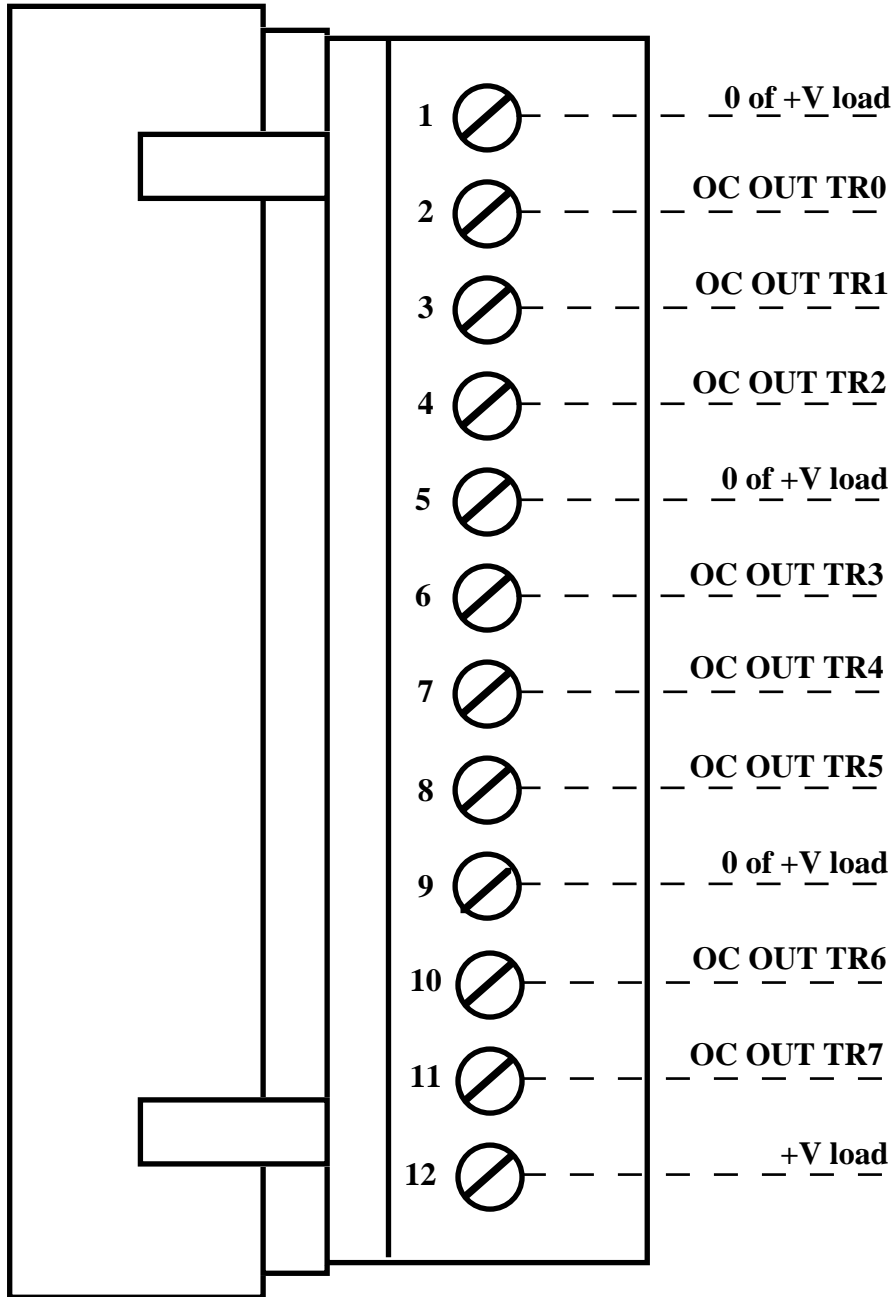

FIGURE 34: CN2 - OUTPUT CONNECTOR

Signals description:

- +V load** = I - Power supply of the load (+45 Vdc max.).
This is also the common point for back EMF protection diodes.
- 0 of +V load** = - Common point for load power supply.
- OC OUT TRn** = O - Open collector power transistor outputs, they must be connected to external loads. These outputs correspond to the input signals P?.n as described.

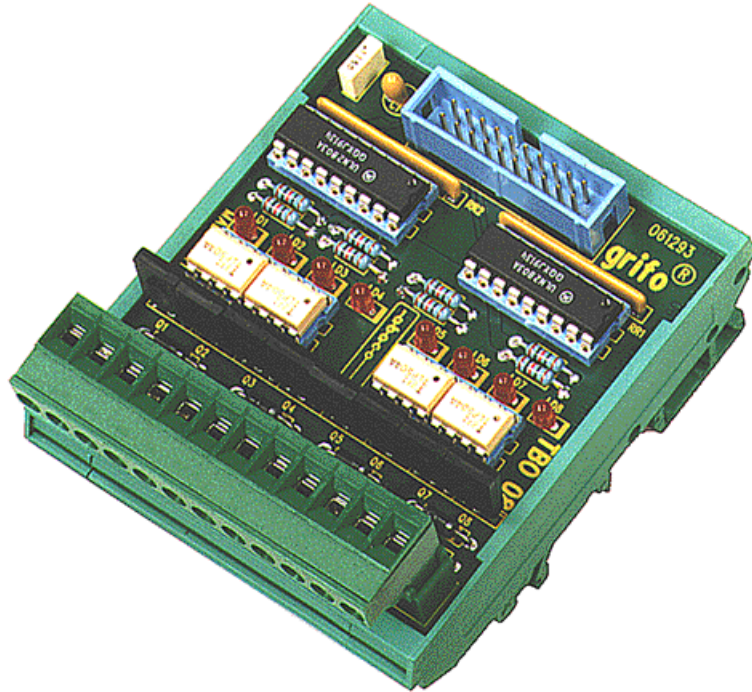

FIGURE 35: TBO 08 CARD PHOTO

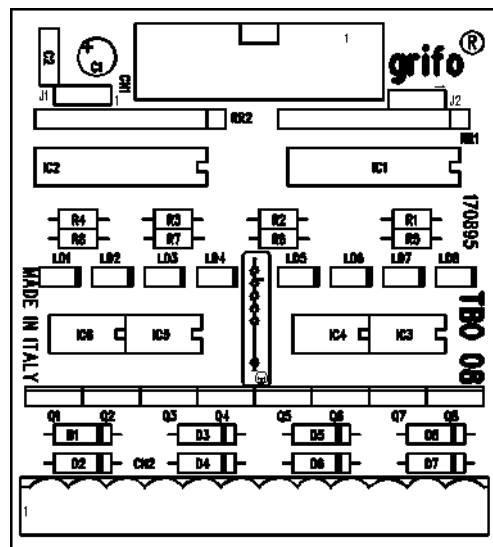

FIGURE 36: TBO 08 COMPONENTS MAP

HARDWARE DESCRIPTION

TBO 08 can interface both port 1 and port 2 available on the 20 pins connector simply moving the buffer ULN 2803 from socket IC1 to socket IC2. When the buffer is installed on **IC1**, the 8 output signals are fetched from **port 2** and viceversa when such component is installed on **IC2**, the outputs are fetched from **port 1**. The choice of which port to use can be performed by the User according to his/her specific needs, being careful not to create electric conflicts when many modules of this family are installed at the same time.

Remarkable and efficient is the protection offered by a back EMF diode, put in parallel connection with the output contacts. Such component offers a high grade of protection against transients that occur when a commutation happens on reactive loads. In fact, when an inductor is removed its power supply, it discharges all the energy previously stored in its magnetic field, creating so a transient that risks to damage the devices connected.

In this specific case, this would destroy the power transistor where the inductive load is connected. To solve this problem the back EMF protection diode has been connected between +V load and the collector of the transistor to protect.

The power output drivers are Darlington transistors BD675A supplied by the voltage +V load (pin 12 of output connector CN2), which must not be greater than 45 Vdc, in addition they are capable to bear about 3A of work current (please refer to data book by SGS Thomson "Discrete Power Device"). Each transistor is installed on the module without heat sink and is located so that it is possible to individuate immediately the output signal it is connected to.

ON BOARD JUMPERS

On **TBO 08** module two 3 pins Jumpers are installed. Jumpers **J1** and **J2** allow to connect the signals of Port 1 and 2 of CN1 to PULL-UP or PULL-DOWN resistors; in detail the description of these jumpers is the following:

- | | | |
|-----------|-----------|---|
| J1 | pos. 1-2: | Connects signals of Port 1 to 8 PULL-UP resistors |
| | pos. 2-3: | Connects signals of Port 1 to 8 PULL-DOWN resistors |
| J2 | pos. 1-2: | Connects signals of Port 2 to 8 PULL-UP resistors |
| | pos. 2-3: | Connects signals of Port 2 to 8 PULL-DOWN resistors |

The port used by **TBO 08** to deliver the signals must be connected to PULL-DOWN resistors, so if the module uses port 1 (ULN 2803 installed on IC2), jumper J2 must be in position 2-3; viceversa if the module **TBO 08** uses port 2 (ULN 2803 installed on IC1), jumper J3 must be in position 2-3. The port not used must be configured according the boards that are going to be connected to it; in particular if it will be connected to boards featuring Output signals (**RBO 01**, **RBO 08**, **another TBO 08**, **XBI T4**, **XBI R4**, etc.), the corresponding Jumper will have to be in position 2-3, if it will be connected to boards featuring Input signals (**OBI P8**, **OBI N8**, etc.), the Jumper will have to be in position 1-2.

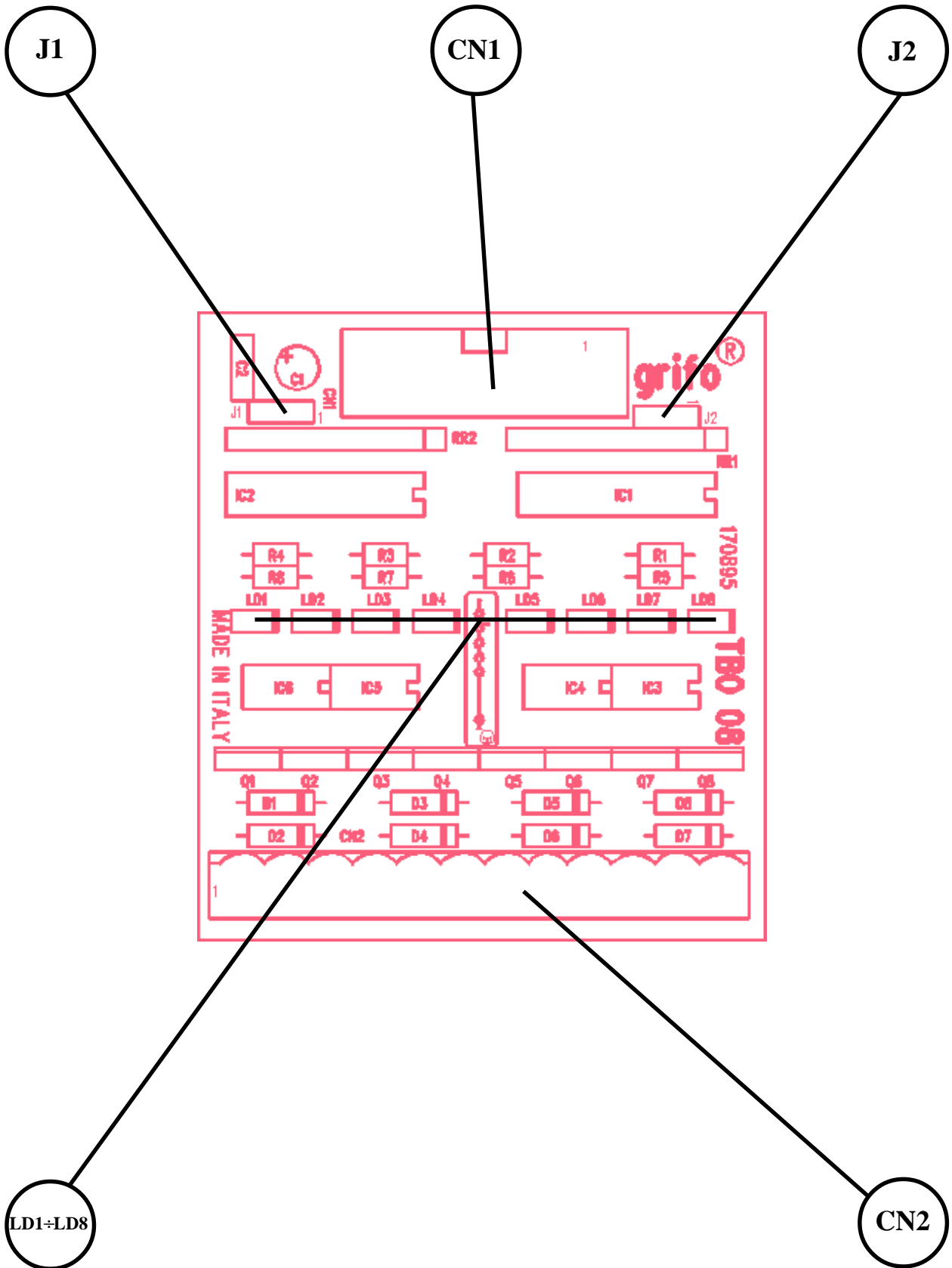

FIGURE 37: TBO 08 JUMPERS, CONNECTORS, LEDS ETC. LOCATION

VISUALIZATIONS

TBO 08 module is provided with eight signalation LEDs to show status information about its signals, as described in the following table:

LEDs	COLOUR	PURPOSE
LD1÷LD8	Red	Visualize the status of the eight transistor outputs, respectively called OC OUT TR0÷OC OUT TR7. A LED on indicates an active output (open collector terminal closed).

FIGURE 38: TBO 08 LEDS TABLE

SOFTWARE DESCRIPTION

The 8 transistor outputs available on **TBO 08**, are managed directly through the bits 0÷7 of the selected port; in detail the corrispondance between bit and output is the following:

Port ?.0	->	OC OUT TR0
Port ?.1	->	OC OUT TR1
Port ?.2	->	OC OUT TR2
Port ?.3	->	OC OUT TR3
Port ?.4	->	OC OUT TR4
Port ?.5	->	OC OUT TR5
Port ?.6	->	OC OUT TR6
Port ?.7	->	OC OUT TR7

Where ? indicates port 1 or 2, according to which socket the component ULN 2803 is installed on, as previously described.

The corrispondance between logic status of bits and signals status is the following:

Bit at logic 0	->	Output not actived	= Transistor contact open
Bit at logic 1	->	Output actived	= Transistor contact closed

I/O CONNECTIONS

To prevent possible connecting problems between **TBO 08** board and the external systems, the User has to read carefully the information of the previous paragraphs and he must follow these instructions:

- The NPN Darlington transistors output signals must be connected directly to the load to drive (power relays, etc.). The board provides the open collector outputs called OC OUT TR_x, capable to bear a maximum current of **3 A non continuative** with a tension that can be **+45 Vdc**.
Being without heat sink, they can drive in continuative way a resistive load absorbing a maximum current of **600 mA** at a tension of **+24 Vdc**, at a working temperature of 20 centigrad degrees. To allow the User to drive several loads having different power supplies, each output section is provided with three differnt COMMON terminals connected to three groups of three, three and two transistors.
- The TTL output signals can be connected directly only to a device featuring the same type of interface. About the correspondance between logic signals and TTL output status, remember that a logic **0** generates a TTL 0 Vdc, while a logic **1** generates a TTL +5 Vdc.

XBI R4

XBI R4 (miXed Block 4 Input 4 relays output) is a **BLOCK** serie module designed to manage and visualize 4 normally open 3A relay outputs and 4 optocoupled NPN inputs, by 8 TTL digital signals. The first section fetches the inputs and their power supply from the external world through a 6 pin quick release screw terminal connector; these signals get buffered and optocoupled to an half of port 2 on the 20 pins I/O **ABACO**® standard connector.

The second section fetches the inputs from the inputs from the remaining half of port 2 through the 20 pins I/O **ABACO**® standard connector; the 3 A outputs reach the external world by means of the 6 pins quick release screw terminal connector.

In this case the parallel interface, in particular port 2, is used both for input and for output, so that port must be programmed for fetching signals from the most significant nibble and driving outputs through the least significant nibble.

XBI R4 module can interface to the several **grifo**® cards, like **GPC**® F2, **GPC**® 51, **GPC**® 552, **GPC**® 011, **GPC**® 188, **PIO 01**, **IAC 01**, etc.

Remarkable and efficient is the protection offered by MOV, put in parallel connection with the output contacts, they are able to suppress nominal +39 Vdc transients that occur when a commutation happens on reactive loads supplied by 24 Vac.

Another remarkable feature of this module is the possibility to supply the relays by +12 Vdc or +24 Vdc, the choice can be made through a jumper installed on the board that configures the relays section for being supplied by one of these two tensions.

Optocouplers can be supplied by a voltage in the range +12÷24 Vdc.

The board features 8 LEDs that provide the User a visual feedback about the status of the 8 signals available on the module **XBI R4**.

XBI R4 is delivered with a plastic mount for DIN 46277-1 and DIN 46277-3 rails.

TECHNICAL FEATURES

N. of optocoupled NPN inputs:	4
N. of power outputs:	4
Size:	70 x 80 x 40 mm
Weight:	150 g
Connectors:	CN1 quick release screw terminal 2 pins CN2 low profile vertical male 20 pins CN3 quick release screw terminal 6 pins CN4 quick release screw terminal 6 pins
Temperature range:	from 0 to 50 centigrad degrees
Relative humidity:	20% up to 90% without condense
Buffer and opto power supply:	+5 Vdc

Max tension on outputs (+Vload):	24 Vac / 24 Vdc Please contact grifo® if You need to connect an higher voltage
Output current on each signal:	3 A
NPN opto inputs power supply:	in the range +12 ÷ +24 Vdc
Relays power supply:	Selectable between +12 Vdc or +24 Vdc
Current consumption on +5 Vdc:	50 mA max
Current consumption on +12/+24 Vdc:	90 mA max

(*) Values referred to working temperature of 20 °C

CN1 - RELAYS SUPPLY CONNECTOR

CN1 is a 2 pins quick release screw terminal connector, it provides power supply for the relays section, its pin out is made as follows:

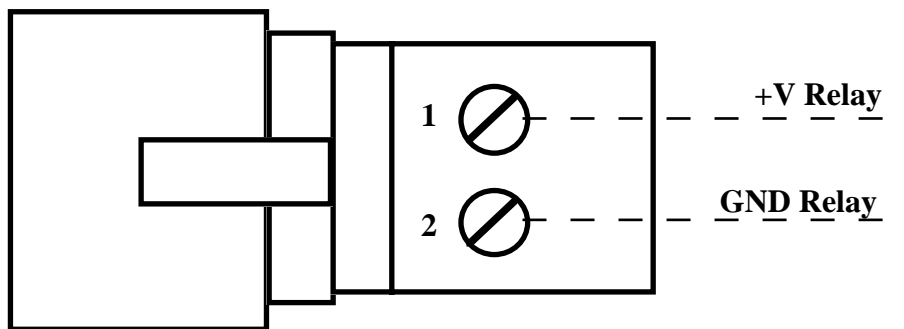

FIGURE 39: CN1 - RELAYS SUPPLY CONNECTOR

Signals description:

+V Relays	=	I	- Power supply for relays section: +12 Vdc or +24 Vdc
GND Relays	=		- Ground for relays section.

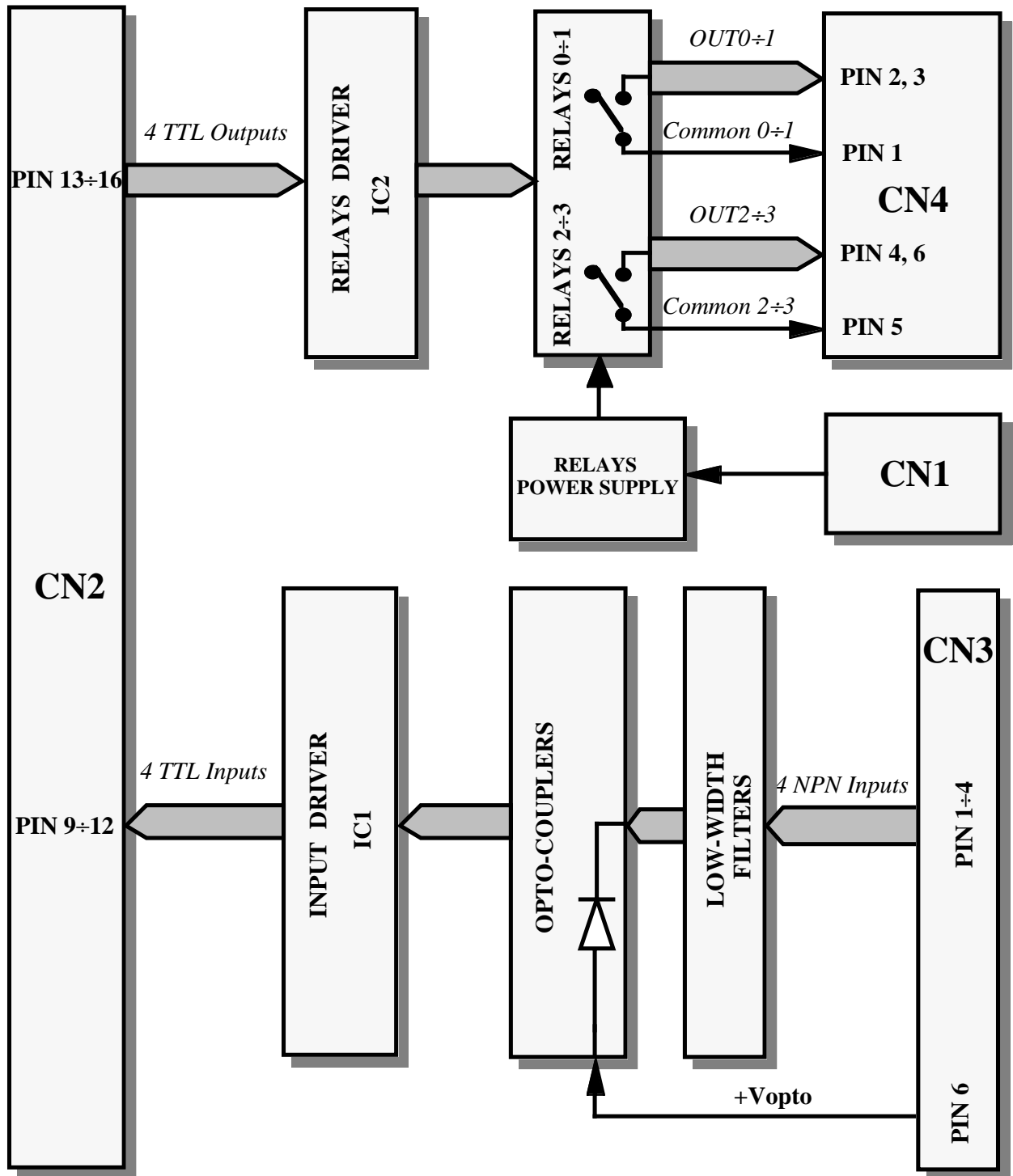

FIGURE 40: XBI R4 BLOCK DIAGRAM

CN2 - I/O ABACO® CONNECTOR

CN2 is a 20 pins low profile male connector, featuring standard I/O ABACO® pin out, where 16 digital I/O TTL signals are available, divided in two ports.

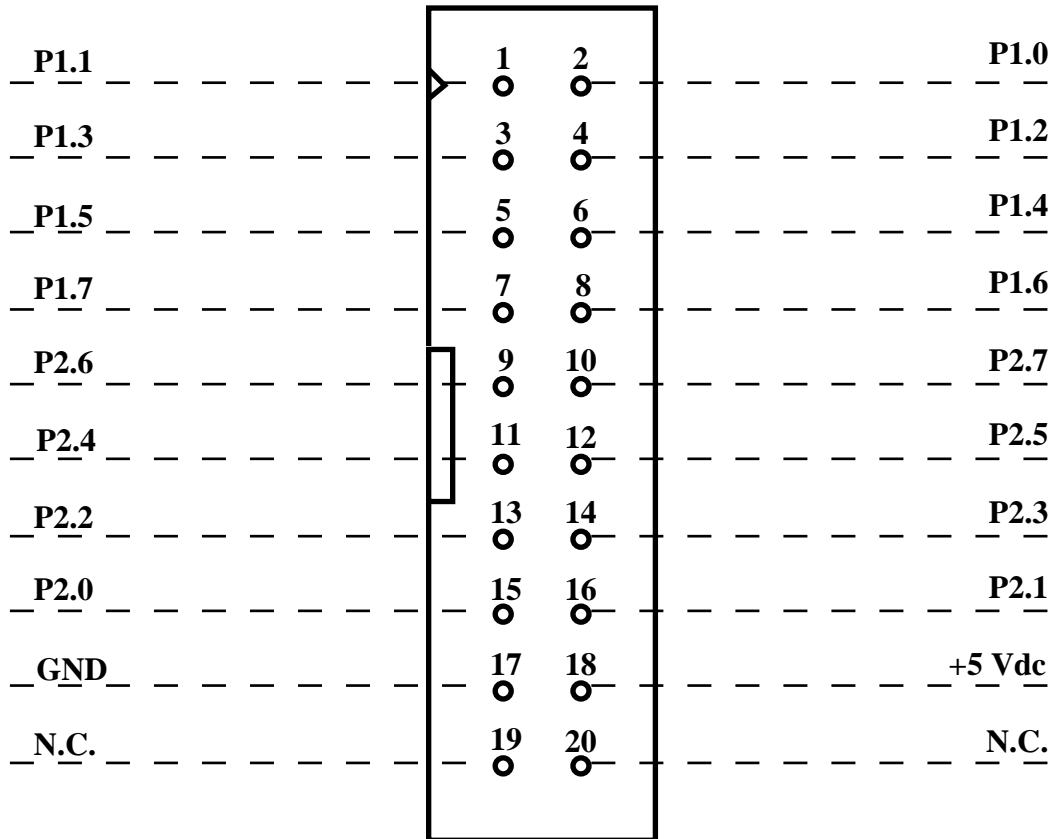

FIGURE 41: CN2 - I/O ABACO® CONNECTOR

Signals description:

P1.n	=	I/O	- n-th signals of port 1.
P2.n	=	I/O	- n-th signals of port 2.
+5 Vdc	=	I/O	- Power supply +5 Vdc.
GND	=		- Ground.
N.C.	=		- Not connected.

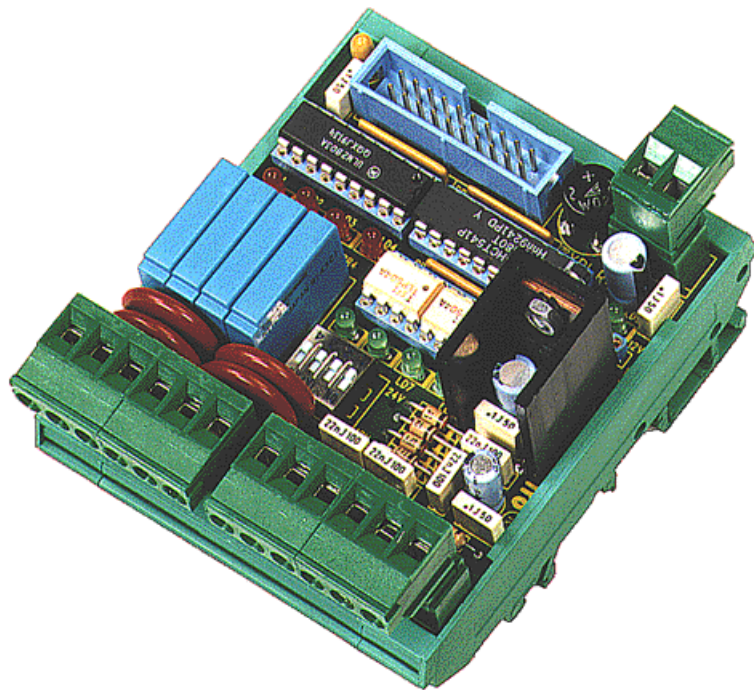

FIGURE 42: XBI R4 CARD PHOTO

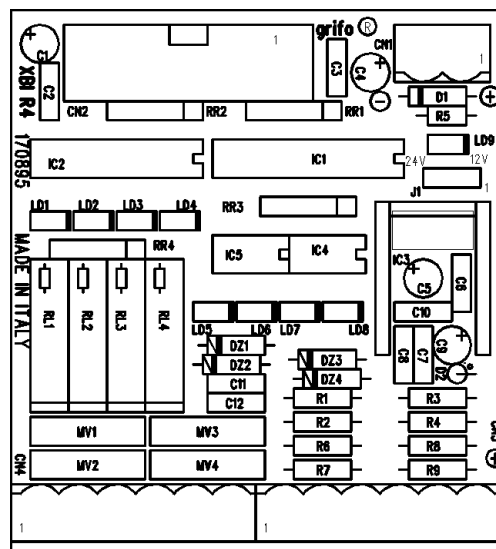

FIGURE 43: XBI R4 COMPONENTS MAP

CN3 - INPUT CONNECTOR

CN3 is a 6 pins quick release screw terminal connector, used to connect the 4 PNP optocoupled inputs corresponding to the most significant nibble of port 2 and the external world.

The following figure refers to a view of the connector from the component side.

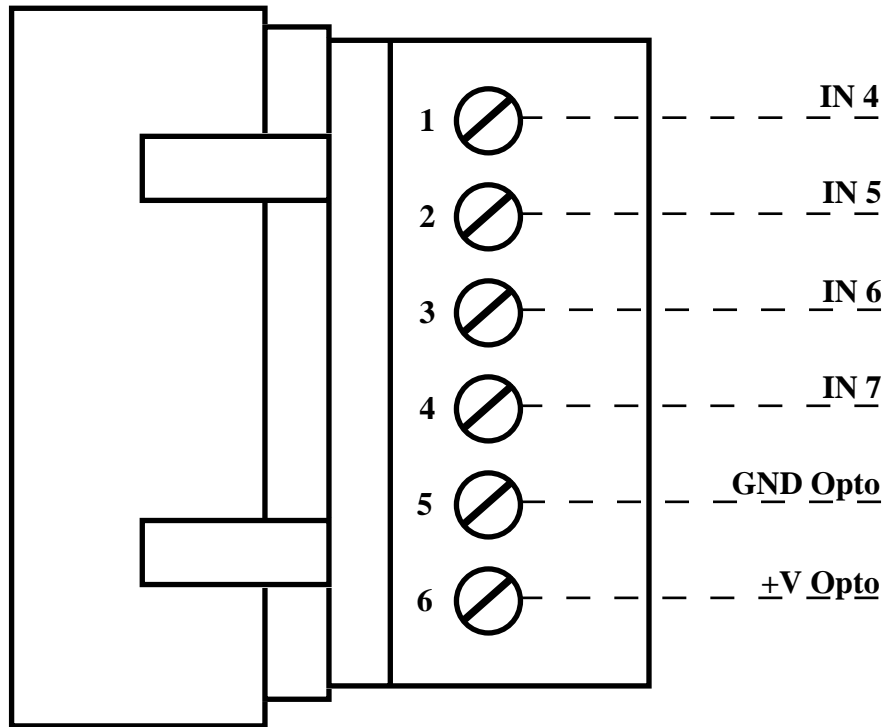

FIGURE 44: CN3 - INPUT CONNECTOR

Signals description:

- IN n** = I - n-th PNP input corresponding to signal P?.n on connector CN1
- +Vopto** = I - Power supply of optocoupled PNP input section i range 12÷24 Vdc.
- GND Opto** = - Ground signal for PNP optocoupled inputs.

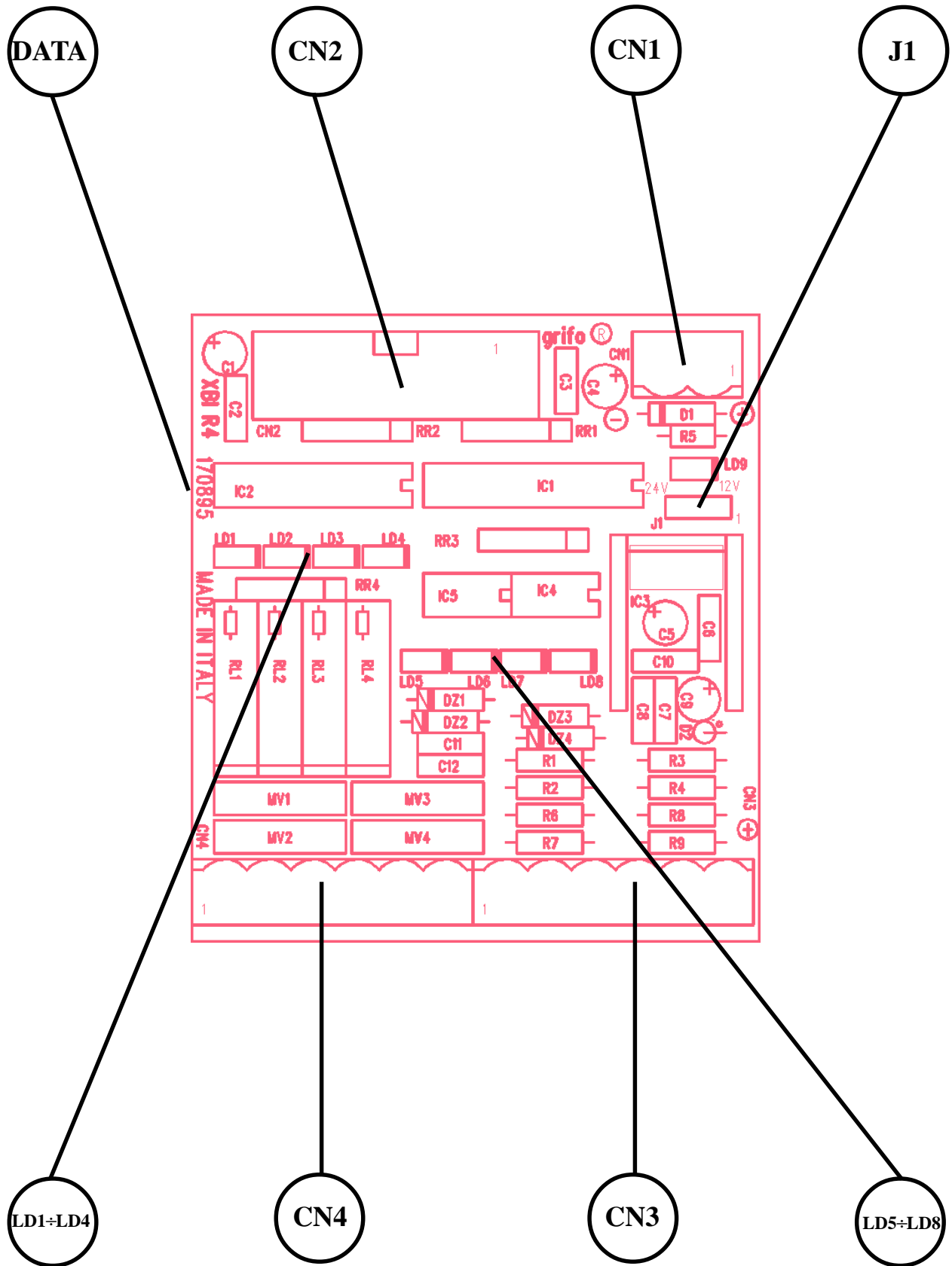

FIGURE 45: XBI R4 JUMPERS, CONNECTORS, LEDS ETC. LOCATION

CN4 - OUTPUT CONNECTOR

CN4 is a 6 pins quick release screw terminal connector, used to connect the 4 relay output corresponding to bits of port 2 most significant nibble and the external world.

The following figure refers to a view of the connector from the component side.

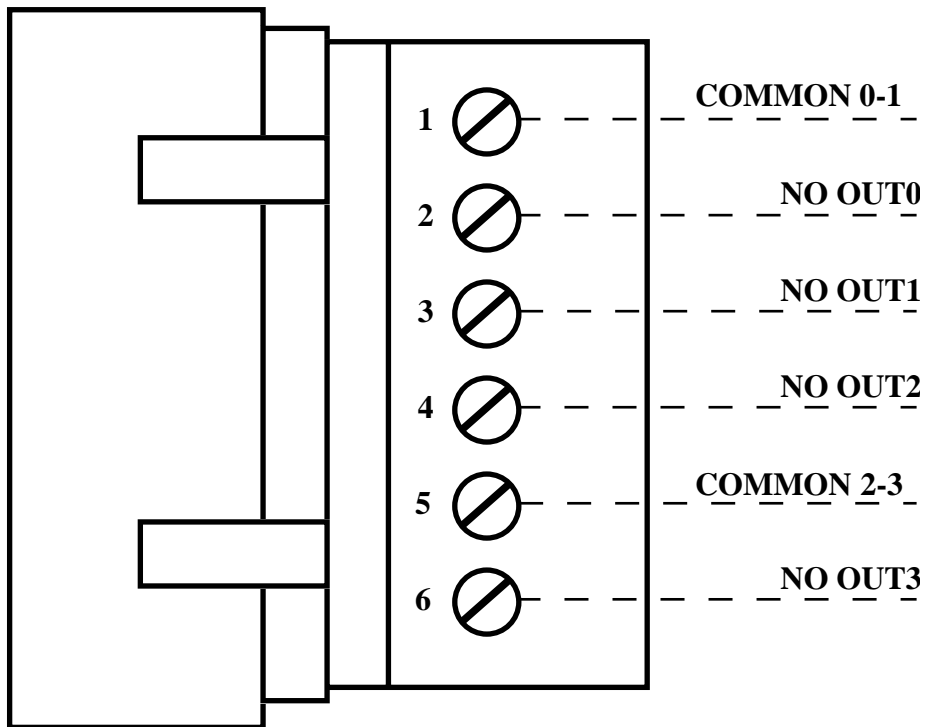

FIGURE 46: CN4 - OUTPUT CONNECTOR

Signals description:

- COMMON 0-1** = - Common contact of the relays in the group NO OUT0-1.
- COMMON 2-3** = - Common contact of the relays in the group NO OUT2-3.
- NO OUTn** = - Normally open contact of n-th relay output.

HARDWARE DESCRIPTION

Remarkable and efficient is the protection offered by MOV, put in parallel connection with the output contacts, they are able to suppress nominal +39 Vdc transients that occur when a commutation happens on reactive loads supplied by 24 Vac. In fact, when an inductor is removed its power supply, it discharges all the energy previously stored in its magnetic field, creating so a transient that risks to damage the devices connected.

The voltage to supply the input optocouplers must be supplied through pins 5 and 6 of CN3 quick release screw terminal connector; this voltage must be in the range from +12 Vdc to +24 Vdc.

VISUALIZATIONS

XBI R4 module is provided with eight signalation LEDs to show status information about its signals, as described in the following table:

LEDs	COLOUR	PURPOSE
LD1÷LD4	Green	Visualize the status of the four optocoupled input signals, respectively IN4÷IN7. A LED on indicates the input contact is connected to GND Opto.
LD5÷LD8	Red	Visualize the status of the four relay outputs, respectively called NO OUT0÷NOOUT3. A LED on indicates an active output (relay contact closed).

FIGURE 47: XBI R4 LEDS TABLE

The module features also a ninth LED, LD9 green, that indicates whether the relays section is supplied by +12 Vdc or +24 Vdc. In detail the correspondance is:

LD9 off	->	Relays section supplied by +12 Vdc (Jumper J1 in position 1-2)
LD9 on	->	Relays section supplied by +24 Vdc (Jumper J1 in position 2-3)

SOFTWARE DESCRIPTION

The 4 relays outputs available on **XBI R4**, are managed directly through the bits 0÷3 of port 2; in detail the corrispondance between bit and output is the following:

Port 2.0	->	NO OUT0
Port 2.1	->	NO OUT1
Port 2.2	->	NO OUT2
Port 2.3	->	NO OUT3

The corrispondance between logic status of bits and signals status is the following:

Bit at logic 0	->	Output not activated	= Relay contact open
Bit at logic 1	->	Output activated	= Relay contact closed

The 4 optocoupled input signals are managed directly through bits 4÷7 of port 2; in detail the corrispondance between bit and input is the following:

Port 2.4	->	IN4
Port 2.5	->	IN5
Port 2.6	->	IN6
Port 2.3	->	IN7

The corrispondance between logic status of bits and signals status is the following:

Bit at 0 logic	->	Input activated	= Input contact connected to GND opto
Bit at 1 logic	->	Input not activated	= Input contact not connected

ON BOARD JUMPERS

On **XBI R4** module one 3 pins Jumpers is installed. Jumper **J1** allows to configure the relays section to be supplied by a tension of +12 Vdc or +24 Vdc. In detail the description of the jumpers is the following:

J1	pos. 1-2	Configures the relays section to be supplied by +12 Vdc
	pos. 2-3	Configures the relays section to be supplied by +24 Vdc

I/O CONNECTIONS

To prevent possible connecting problems between **XBI R4** board and the external systems, the User has to read carefully the information of the previous paragraphs and he must follow these instructions:

- To connect to the optocoupled input signals, only the contacts to acquire must be connected from the external system(s). These contacts (relays, switches, etc.) must connect or not connect the input signal INx to GND opto. About the correspondance between logic signals and contact status, an open contact generates a logic **1**, a closed contact generates a logic **0**, following the NPN standard.
- The relays output signals must be connected directly to the load to drive (power relays, etc.). The board provides the normally open contacts called NO OUTx, capable to bear a maximum current of **3 A** with a tension that can be **24 Vdc** or **24 Vac**.

To allow the User to drive several loads having different power supplies, each output section is provided with two differnt COMMON terminals connected to two groups of Three and one relays.

NOTE: Should the User connect to the relays a voltage higher to the one declared in this manual, please contact **grifo®** directly; in fact this implies a different hardware configuration that must be performed by **grifo®** technicians.

- The TTL output signals can be connected directly only to a device featuring the same type of interface. About the correspondance between logic signals and TTL output status, remember that a logic **0** generates a TTL 0 Vdc, while a logic **1** generates a TTL +5 Vdc.

XBI T4

XBI T4 (miXed Block 4 Input 4 transistor output) is a **BLOCK** serie module designed to manage and visualize 4 open collector 3A transistor outputs and 4 optocoupled NPN inputs, by 8 TTL digital signals.

The first section fetches the inputs and their power supply from the external world through a 6 pin quick release screw terminal connector; these signals get buffered and optocoupled to an half of port 2 on the 20 pins I/O **ABACO**[®] standard connector.

The second section fetches the inputs from the inputs from the remaining half of port 2 through the 20 pins I/O **ABACO**[®] standard connector; the 3 A outputs reach the external world by means of the 6 pins quick release screw terminal connector.

In this case the parallel interface, in particular port 2, is used both for input and for output, so that port must be programmed for fetching signals from the most significant nibble and driving outputs through the least significant nibble.

XBI T4 module can interface to the several **grifo**[®] cards, like **GPC**[®] **F2**, **GPC**[®] **51**, **GPC**[®] **552**, **GPC**[®] **011**, **GPC**[®] **188**, **PIO 01**, **IAC 01**, etc.

Remarkable and efficient is the protection offered by back EMF diodes on the power transistors, especially useful in case of inductive loads.

Optocouplers can be supplied by a voltage in the range +12÷24 Vdc.

The board features 8 LEDs that provide the User a visual feed back about the status of the 8 signals available on the module **XBI T4**.

XBI T4 is delivered with a plastic mount for DIN 46277-1 and DIN 46277-3 rails.

TECHNICAL FEATURES

N. of optocoupled NPN inputs:	4
N. of power outputs:	4
Size:	70 x 80 x 40 mm
Weight:	120 g
Connectors:	CN1 quick release screw terminal 2 pins CN2 low profile vertical male 20 pins CN3 quick release screw terminal 6 pins CN4 quick release screw terminal 6 pins
Temperature range:	from 0 to 50 centigrad degrees
Relative humidity:	20% up to 90% without condense
Buffer and opto power supply:	+5 Vdc
Maximum output voltage (+V load):	+45 Vdc

- Maximum output current per signal:** 3 A non continuative (*)
600 mA continuative, supplying a resistive load at +24 Vdc
- Maximum power without heat sink:** 1.25 W (*)
- Optocoupled NPN input section power supply:** in the range +12 ÷ +24 Vdc
- Current consumption on +5 Vdc:** 60 mA max (*)

For further information about driver BD 675A, please refer to data book “Discrete Power Device” by SGS THOMSON or equivalent.

(*) Values referred to working temperature of 20 °C

CN1 - I/O ABACO® CONNECTOR

CN1 is a 20 pins low profile male connector, featuring standard I/O ABACO® pin out, where 16 digitaldi I/O TTL signals are available, divided in two ports.

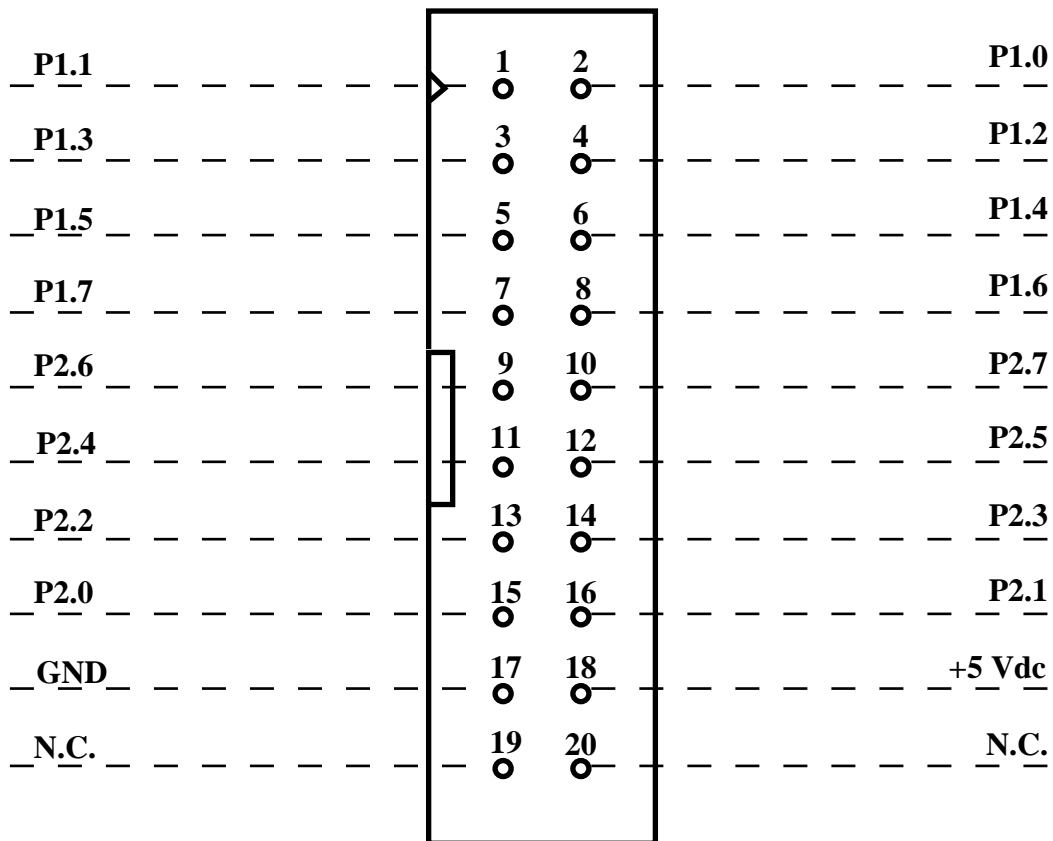

FIGURE 48: CN1 - I/O ABACO® CONNECTOR

Signals description:

- P1.n** = I/O - n-th signals of port 1.
- P2.n** = I/O - n-th signals of port 2.
- +5 Vdc** = I/O - Power supply +5 Vdc.
- GND** = - Ground.
- N.C.** = - Not connected.

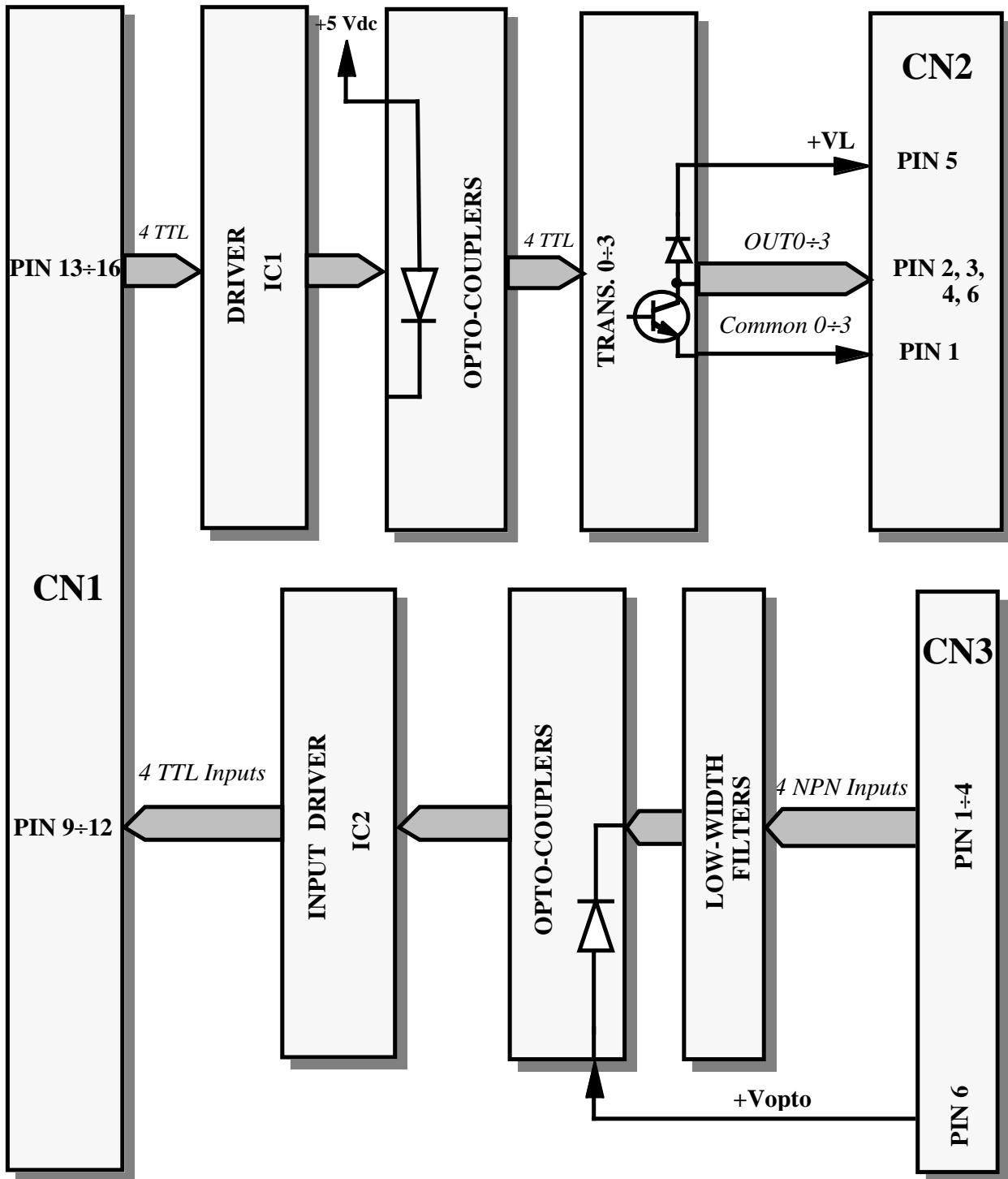

FIGURE 49: XBI T4 BLOCK DIAGRAM

CN2 - OUTPUT CONNECTOR

CN2 is a 6 pins quick release screw terminal connector, used to connect the 4 transistor output corresponding to bits of port 2 least significant nibble and the external world.

The following figure refers to a view of the connector from the component side.

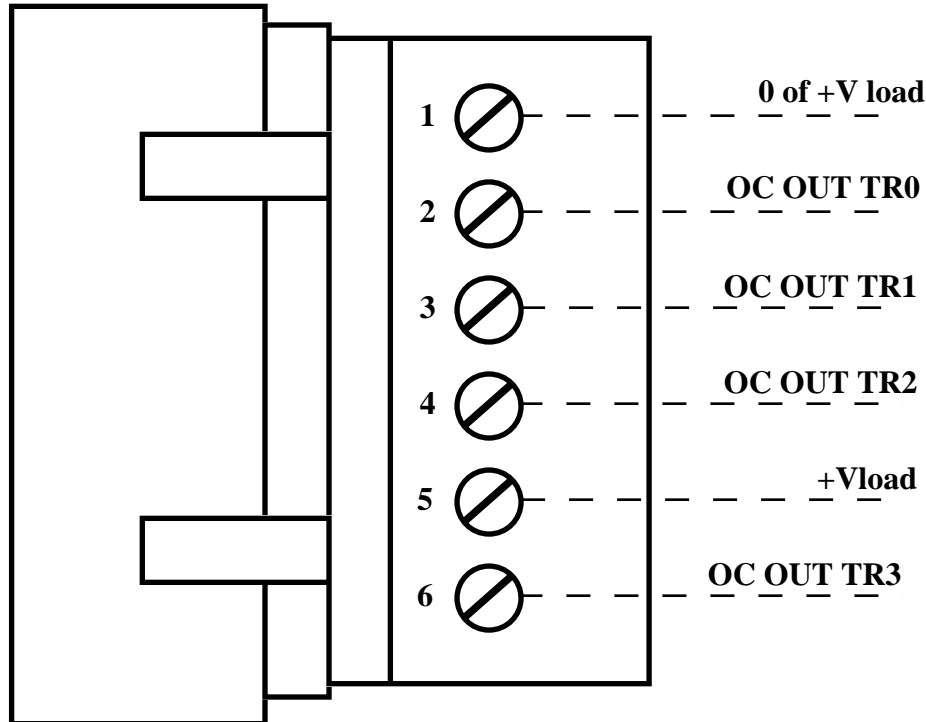

FIGURE 50: CN2 - OUTPUT CONNECTOR

Signals description:

+V load	=	I	- Power supply of the load (+45 Vdc max.). This is also the common point for back EMF protection diodes.
0 of +V load	=		- Common point for load power supply.
OC OUT TRn	=	O	- Open collector power transistor outputs, they must be connected to external loads. These outputs correspond to the input signals P2.n as described.

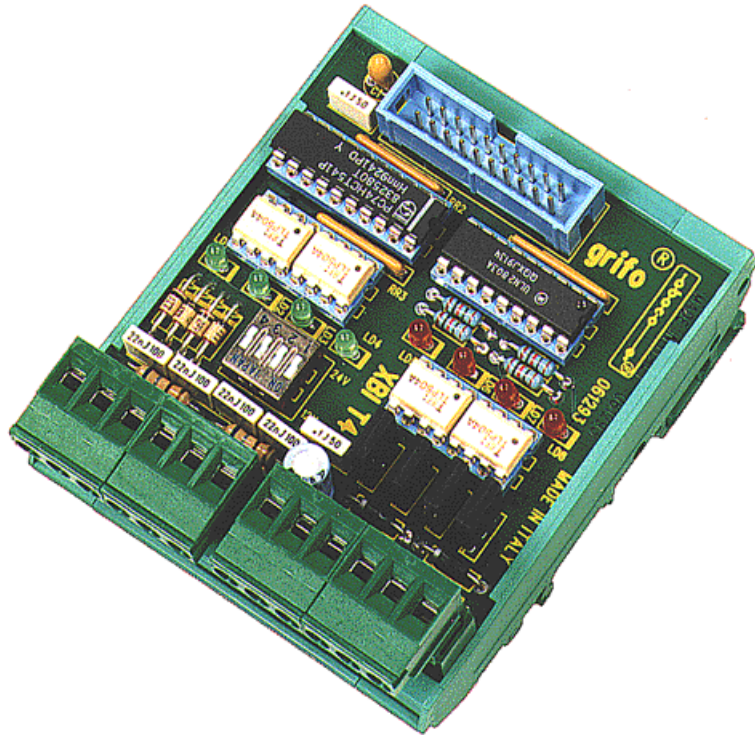

FIGURE 51: XBI T4 CARD PHOTO

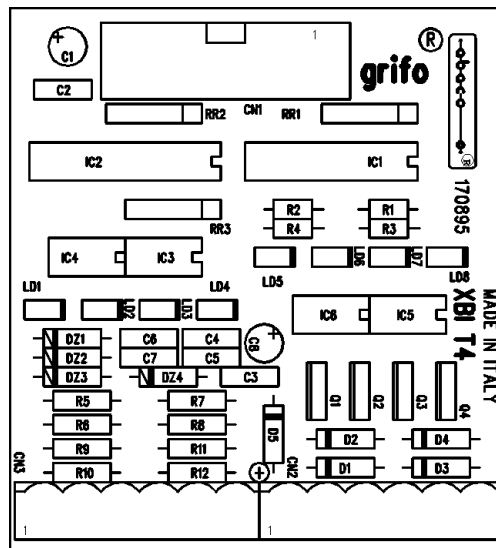

FIGURE 52: XBI T4 COMPONENTS MAP

CN3 - INPUT CONNECTOR

CN3 is a 6 pins quick release screw terminal connector, used to connect the 4 PNP optocoupled inputs corresponding to the most significant nibble of port 2 and the external world.

The following figure refers to a view of the connector from the component side.

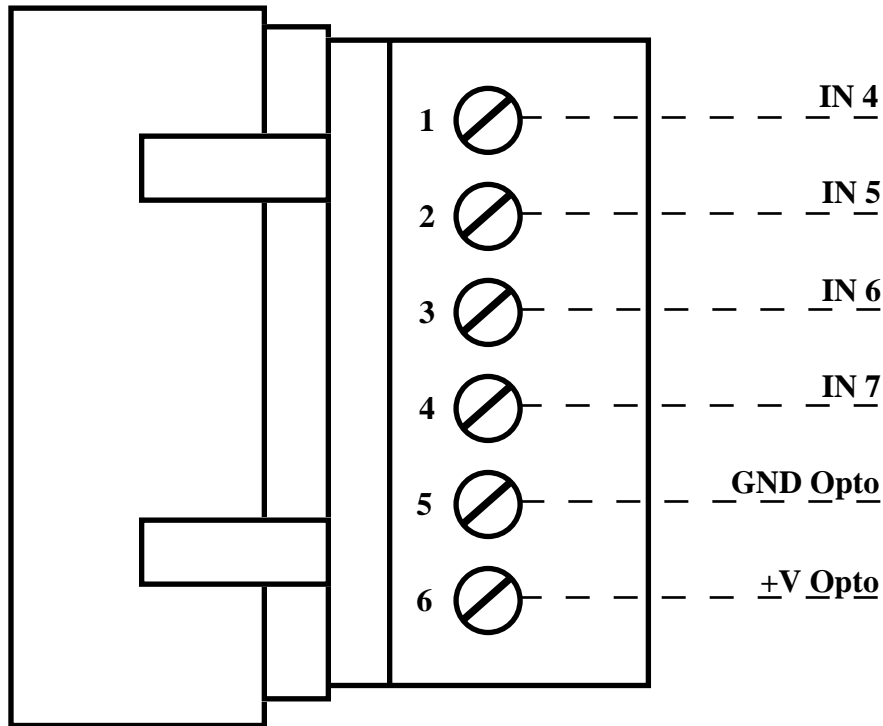

FIGURE 53: CN3 - INPUT CONNECTOR

Signals description:

IN n	=	I	- n-th PNP input corresponding to signal P?.n on connector CN1
+Vopto	=	I	- Power supply of optocoupled PNP input section i range 12÷24 Vdc.
GND Opto	=		- Ground signal for PNP optocoupled inputs.

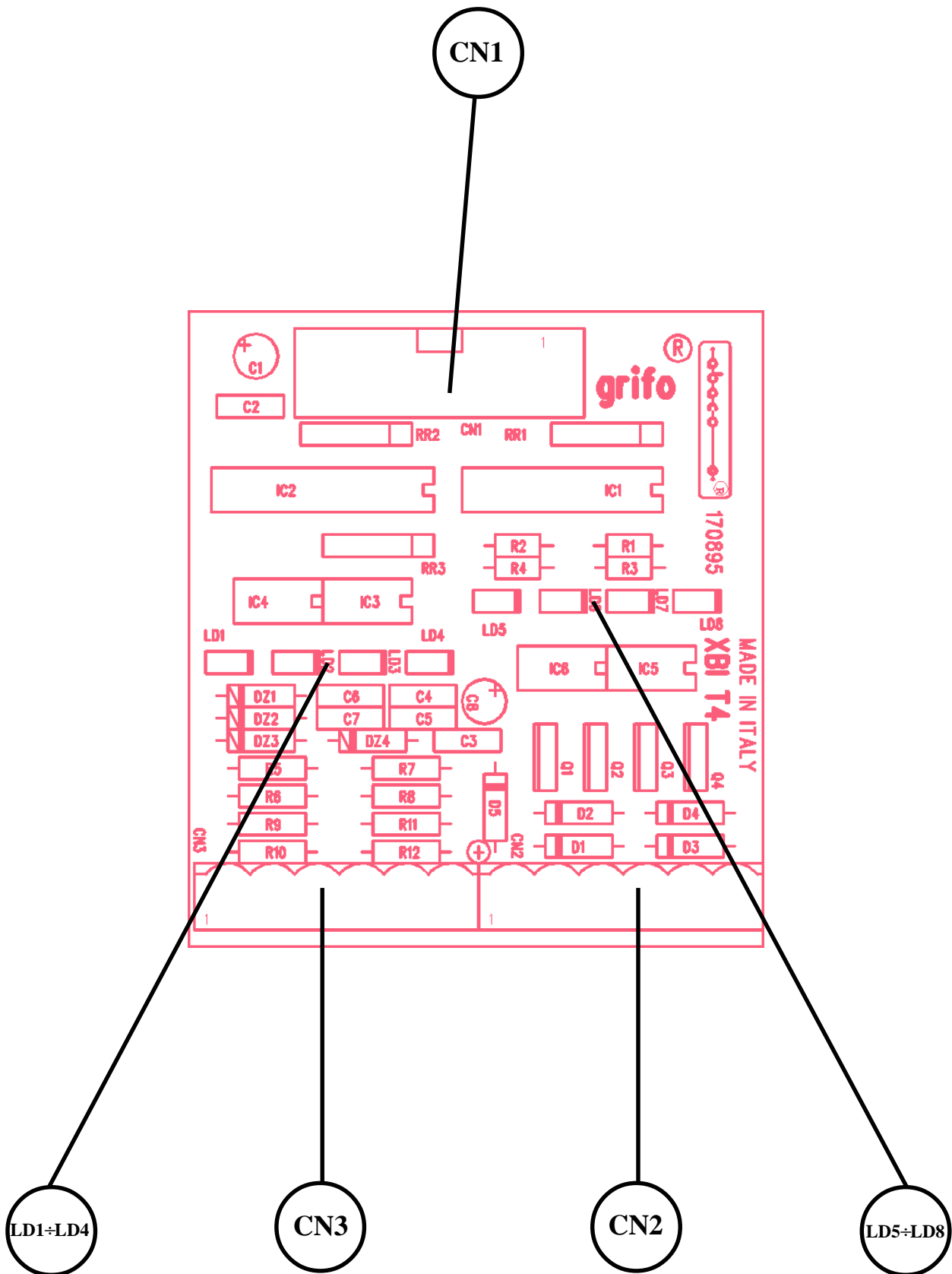

FIGURE 54: XBI T4 JUMPERS, CONNECTORS, LEDS ETC. LOCATION

HARDWARE DESCRIPTION

Remarkable and efficient is the protection offered by a back EMF diode, put in parallel connection with the output contacts. Such component offers a high grade of protection against transients that occur when a commutation happens on reactive loads. In fact, when an inductor is removed its power supply, it discharges all the energy previously stored in its magnetic field, creating so a transient that risks to damage the devices connected.

In this specific case, this would destroy the power transistor where the inductive load is connected. To solve this problem the back EMF protection diode has been connected between +V load and the collector of the transistor to protect.

The power output drivers are Darlington transistors BD675A supplied by the voltage +V load (pin 5 of connector CN2), which must not be greater than 45 Vdc, in addition they are capable to bear about 3A of work current (please refer to data book by SGS Thomson "Discrete Power Device"). Each transistor is installed on the module without heat sink and is located so that it is possible to individuate immediately the output signal it is connected to.

The voltage that supplies the input optocouplers must be provided between pins 5 and 6 of input connector CN3; such voltage must be included in the range from +12 Vdc to +24 Vdc.

I/O CONNECTIONS

To prevent possible connecting problems between **XBI T4** board and the external systems, the User has to read carefully the information of the previous paragraphs and he must follow these instructions:

- To connect to the optocoupled input signals, only the contacts to acquire must be connected from the external system(s). These contacts (relays, switches, etc.) must connect or not connect the input signal INx to GND opto. About the correspondance between logic signals and contact status, an open contact generates a logic **1**, a closed contact generates a logic **0**, following the NPN standard.
- The NPN Darlington transistors output signals must be connected directly to the load to drive (power relays, etc.). The board provides the open collector outputs called OC OUT TRx, capable to bear a maximum current of **3 A non continuative** with a tension that can be **+45 Vdc**. Being without heat sink, they can drive in continuative way a resistive load absorbing a maximum current of **600 mA** at a tension of **+24 Vdc**, at a working temperature of 20 centigrad degrees. To allow the User to drive several loads having different power supplies, each output section is provided with two different COMMON terminals connected to two groups of eight relays.
- The TTL output signals can be connected directly only to a device featuring the same type of interface. About the correspondance between logic signals and TTL output status, remember that a logic **0** generates a TTL 0 Vdc, while a logic **1** generates a TTL +5 Vdc.

SOFTWARE DESCRIPTION

The 4 transistor outputs of **XBI T4** are managed directly through bits 0÷4 of port 2; in detail the correspondance between bit and output is the following:

Port 2.0	->	OUT TR0
Port 2.1	->	OUT TR1
Port 2.2	->	OUT TR2
Port 2.3	->	OUT TR3

The correspondance between logic status of bits and signals status is the following:

Bit at logic 0	->	Output not activated	= Transistor contact open
Bit at logic 1	->	Output activated	= Transistor contact closed

The 4 optocoupled input signals are managed directly through bits 4÷7 of port 2; in detail the correspondance between bit and output is the following:

Port 2.4	->	IN4
Port 2.5	->	IN5
Port 2.6	->	IN6
Port 2.3	->	IN7

The correspondance between logic status of bits and signals status is the following:

Bit at logic 0	->	Input activated	= Input contact closed to GND opto
Bit at logic 1	->	Input not activated	= Input contact open

VISUALIZATIONS

XBI T4 module is provided with eight signalation LEDs to show status information about its signals, as described in the following table:

LEDs	COLOUR	PURPOSE
LD1÷LD4	Green	Visualize the status of the four optocoupled input signals, respectively IN4÷IN7. A LED on indicates the input contact is connected to GND Opto.
LD5÷LD8	Red	Visualize the status of the four relay outputs, respectively called OC OUT TR0÷OC OUT TR3. A LED on indicates an active output (open collector terminal closed).

FIGURE 55: XBI T4 LEDS TABLE

EXTERNAL CARDS

BLOCK modules can interface to most of **grifo**® industrial boards. Their main purpose is to perform a digital Input/Output interfacing between CPU (**GPC**®) cards and the external world. Here is reported an illustrative list of cards capable to interact with **BLOCK** modules with a short description of their features; for further informations please request the specific documentation.

GPC® 51

General Purpose Controller fam. 51

Microprocessor family 51 INTEL including the masked BASIC chip; the board features: 16 I/O TTL lines; dip switch; 3 timer/counter; RS 232; 4 A/D converter signals resolution 11 bit; buzzer; on board EPROM programmer; RTC and 32K SRAM with Lithium battery back up; controller for display and keyboard.

GPC® 535

General Purpose Controller 80535

80535 CPU; 16 TTL I/O lines; Watch Dog; Incremental encoder 3 lines counter; 64K EPROM; 32K RAM Lithium battery backed; RTC; 8 A/D 10 bits lines; 1 RS 232 or RS 485 line; Buzzer; Dip switch; 4 Timer.

GPC® 68

General Purpose Controller 68000

1 RS 232 line; 1 RS 232 line or RS 422-485 line with settable Baud Rate up to 38K Baud; 3 8 bits parallel ports and 3 timer counter; 10 MHz 68000 CPU; 768 KByte RAM EPROM; disconnectable Watch dog.

GPC® 180

General Purpose Controller Z180

Z180 μ P, Z80 compatible code; 1 RS 232 line, 1 RS 232 line or 422-485; 1 MByte RAM/EPROM of which 384K RAM Lithium battery backed; 48 TTL I/O lines; RTC; Watch dog; Dip switch, RAM write protected.

GPC® 188F

General Purpose Controller 80C188

80C188 μ P 20MHz; 1 RS 232 line; 1 RS 232, RS 422-485 or Current Loop line; 24 TTL I/O lines; 1M EPROM or 512K FLASH; 1M RAM Lithium battery backed; 8K serial EEPROM; RTC; Watch Dog; 8 Dip switch; 3 Timer Counter; 8 13 bit A/D lines; Power failure; activity LEDs; single power supply +5Vdc.

GPC® 80F

General Purpose Controller 84C00

Z80 μ P, 8 to 10 MHz, full CMOS; 256K EPROM or FLASH; RTC and 256K RAM Lithium battery backed; 1 RS 232 line; 1 RS232 or 422-485 or Current Loop line; 16 TTL I/O lines; CTC; Watch dog; Dip switch.

GPC® 81F

General Purpose Controller 84C00

Z80 μ P, 8 to 10 MHz, full CMOS; 512K EPROM or FLASH; 64K RAM; 8K RAM and RTC backed; 8K serial EEPROM; 1 RS 232 line; 1 RS232 or 422-485 or Current Loop line; 24 TTL I/O lines; 4 A/D 11 bits lines; Watch dog; Dip switch.

GPC® 15A

General Purpose Controller 84C15

Full CMOS card, 10÷20 MHz 84C15 CPU; 512K EPROM or FLASH; 128K RAM; 8K RAM and RTC backed; 8K serial EEPROM; 1 RS 232 line; 1 RS 232 line or RS 422-485 or Current Loop line; 32 or 40 TTL I/O lines; CTC; Watch dog; 2 Dip switches; Buzzer.

GPC® 15R

General Purpose Controller 84C15

84C15 μ P, 10÷16 MHz; 1 RS 232 line; 1 RS 232 or RS 422-485 or C. L. line; 16÷24 TTL I/O lines; 16 Opto-in; 8 Relays; 4 Opto Coupled Timers Counters; 512K EPROM or FLASH; 512K RAM and RTC backed; 8K serial EEPROM; 8K Backed RAM modul; Buzzer; 1 Activity LED; Watch dog; 4÷12 readable DIPs; LCD Interface.

GPC® 011

General Purpose Controller 84C011

84C011 μ P; 8 MHz; Full CMOS; 1 RS 232 line; 1 RS 232 or RS 422-485; 40 TTL I/O lines; 4 A/D 11 bits lines; 4 Timers Counters; 256K EPROM or FLASH; 256K RAM and RTC backed; Watch dog; 8 readable DIPs; LCD Interface.

GPC® 552

General Purpose Controller 80C552

80C552 μ P; 22÷33 MHz; Full CMOS; 1 software RS 232 line; 1 RS 232 or RS 422-485 or C. L. line; 44 TTL I/O lines; 8 10 bits A/D lines; 3 Timers Counters; 64K EPROM; 64K RAM; 32K RAM and RTC backed; 32 DIL EEPROM; 8K serial EEPROM; Buzzer; 2 PWM lines; 1 Activity LED; Watch dog; 8 readable DIPs; LCD Interface.

GPC® 11

General Purpose Controller 68HC11

68HC11 μ P; 8÷16 MHz; Full CMOS; 1 RS 232 or RS 422-485; 32 TTL I/O lines; 8 A/D 8 bits lines; 1÷3 Timers Counters; 32K EPROM; 32K RAM; RTC; 512 byte internal EEPROM; 8K Backed RAM modul; Watch dog; LCD Interface.

GPC® 05

General Purpose Controller 146805

146805 μ P; 5 MHz; Full CMOS; 1 RS 232 or RS 422-485 or Current Loop line; 32 TTL I/O lines; 1 Timers Counters; 8K EPROM; 4K RAM; RTC backed; 2K Backed RAM modul; 1 Activity LED; Watch dog; LCD Interface.

PIO 01

Peripheral Input Output; 96 I/O

96 TTL input output lines which are divided in 12 ports 8 bits each: 6 standard ABACO® I/O 20 pins connectors; Extended addressing; Watch dog.

IAC 01

Interface Adapter Centronics

Interface between 16 I/O TTL on standard connector I/O **ABACO**® and D type 25 pins female connector featuring standard pin out Centronics to interface with the parallel port of a Personal Computer.

IPC 52

Intelligent Peripheral Controller 24 analogic inputs

This card acquires: 8 PT 100/1000; 8 J,K,S,T termocouples; 8 analog input $\pm 2V_{dc}$ or $4\div 20mA$; 16 bit + sign A/D section; 0,1 °C resolution; 32K RAM for local data-logging; Buzzer; 16 TTL I/O lines; 5/8 conversion/second; Facility of networking up 127 IPC 52 cards using serial line. BUS interfacing or through RS 232/422/485 or C. L. line.

GPC® 553

General Purpose Controller 80C552

80C552 μP , 22÷33 MHz; 1 RS 232 line (software); 1 RS 232 or RS 422-485 or Current Loop line; 16 TTL I/O lines; 8 A/D 10 bits lines; 3 Timers Counters; 64K EPROM; 64K RAM; 32K RAM and RTC backed; 32K DIL EEPROM; 8K serial EEPROM; 2 PWM lines; 1 Activity LED; Watch dog; 5 readable DIPs; LCD Interface.

GPC® 153

General Purpose Controller Z80

84C15 μP , 10÷16 MHz; Full CMOS; 1 RS 232 line; 1 RS 232 or RS 422-485 or Current Loop line; 16 TTL I/O lines; 8 A/D 12 bits lines; 2÷4 Timers Counters; 512K EPROM or FLASH; 512K RAM and RTC backed; 8K serial EEPROM; Buzzer; 1 Activity LED; Watch dog; 8 readable DIPs; LCD Interface.

GPC® 183

General Purpose Controller Z180

Z180 μP , 10÷16 MHz; Full CMOS; 1 RS 232 line; 1 RS 232 or RS 422-485 or Current Loop line; 24 TTL I/O lines; 11 A/D 12 bits lines; 2 Timers Counters; 512K EPROM or FLASH; 512K RAM and RTC backed; 8K serial EEPROM; Buzzer; 2 Activity LED; Watch dog; 4 readable DIPs; LCD Interface.

GPC® 323

General Purpose Controller 51 family

80C32 μP , 14 MHz; Full CMOS; 1 RS 232 line (software); 1 RS 232 or RS 422-485 or Current Loop line; 24 TTL I/O lines; 11 A/D 12 bits lines; 3 Timers Counters; 64K EPROM; 64K RAM; 32K RAM and RTC backed; 32K DIL EEPROM; 8K serial EEPROM; Buzzer; 2 Activity LED; Watch dog; 5 readable DIPs; LCD Interface.

GPC® 154

"4" Type General Purpose Controller Z80

84C15 μP , 10÷16 MHz; Full CMOS; 1 RS 232 line; 1 RS 232 or RS 422-485 line; 16 TTL I/O lines; 2÷4 Timers Counters; 512K EPROM or FLASH; 512K RAM and RTC backed; 8K serial EEPROM; Watch dog; 2 readable DIPs; LCD Interface; Abaco® I/O BUS; 5Vdc Power supply; Size: 100x50 mm.

GPC® 324/D

“4” Type General Purpose Controller 80C32/320

80C32 or 80C320 μ P, 14÷22 MHz; Full CMOS; 1 RS 232 line; 1 RS 232 or RS 422-485 or Current Loop line; 4÷16 TTL I/O lines; 3 Timers Counters; 64K EPROM; 64K RAM; 32K RAM backed; 32K DIL E2; 8K serial EEPROM; Watch dog; 1 readable DIP; LCD Interface; Abaco® I/O BUS; 5Vdc Power supply; Size: 100x50 mm.

GPC® 554

General Purpose Controller 80C552

Microprocessor 80C552 at 22 MHz; implementation completely CMOS; 32K EPROM; 32 K SRAM; 32 K EEPROM or SRAM; EEPROM; 2 RS 232 serial lines; 16 I/O TTL; 2 PWM lines; 16 bits Timer/Counter; Watch Dog; 6 signals A/D converter with resolution 10 bit; interface for **ABACO®** I/O BUS.

GPC® 184

“4” Type General Purpose Controller Z180

Z180 μ P, 10÷16 MHz; Full CMOS; 1 RS 232 line; 1 RS 232 or RS 422-485 or Current Loop line; 2 Timers Counters; 512K EPROM or FLASH; 512K RAM and RTC backed; Watch dog; 1 readable DIP; LCD Interface; Abaco® I/O BUS; 5Vdc Power supply; Size: 100x50 mm.

GPC® 884

General Purpose Controller Am188ES

Microprocessor AMD Am188ES up to 40 MHz 16 bits; implementation completely CMOS; serie 4 format; 512K EPROM or FLASH; 512K SRAM backed with Lithium battery; RTC; 1 RS 232 serial line + 1 RS 232 or RS 422-485 or current loop; 16 I/O TTL; 3 timer/counter; watch dog; EEPROM; 11 signals A/D converter with 12 bit resolution; interface for **ABACO®** I/O BUS.

GPC® 114

General Purpose Controller 68HC11

Microprocessor 68HC11A1 at 8 MHz; implementation completely CMOS; serie 4 format; 32K EPROM; 32K SRAM backed with Lithium battery; 32K EPROM, SRAM, EEPROM; RTC; 1 serial line RS 232 or RS 422-485; 10 I/O TTL; 3 timer/counter; watch dog; 8 signals A/D converter with resolution 8 bit; 1 asynchronous serial line; extremely low power consumption; interface for **ABACO®** I/O BUS.

BIBLIOGRAPHY

Here follows a list of manuals and technical notes that the User can read to acquire more informations about **BLOCK** modules.

Manual SGS-THOMSON: *Industrial and Computer Peripheral ICs - Data Book*

Manual SGS-THOMSON: *Small Signal Transistors - Data Book*

Manual TEXAS INSTRUMENTS: *The TTL data Book - SN54/74 Families*

Manual TOSHIBA: *Photo Couplers - Data Book*

Manual MOTOROLA: *Bipolar Power Transistor Data*

Manual NATIONAL: *Linear 1 Databook*

Please connect to the manufactures Web sites to get the latest version of all manuals and data sheets.



APPENDIX A: ALPHABETICAL INDEX

B

BIBLIOGRAPHY **68**
BUFFER AND OPTO POWER SUPPLY **45, 55**
BUFFER POWER SUPPLY **3, 11, 19, 27**

C

CARD VERSION **1**
CURRENT CONSUMPTION **3, 11, 19, 27, 37, 46, 56**
CURRENT CONSUMPTION ON +12/+24 VDC **19**

E

EXTERNAL CARDS **64**

H

HARDWARE DESCRIPTION **8, 16, 24, 35, 42, 53, 62**

I

I/O CONNECTIONS **10, 18, 27, 37, 46, 57, 65**
INTRODUCTION **1**

L

LEDS **8, 16, 26, 35, 44, 53, 62**

M

MANUAL INTRODUCTION **2**
MAX CURRENT ON OUTPUTS **19, 27**
MAX TENSION ON OUTPUTS (+VLOAD) **19, 27, 37, 46, 55**
MAXIMUM OUTPUT CURRENT PER SIGNAL **56**
MAXIMUM POWER WITHOUT HEAT SINK **56**

N

N. OF POWER OUTPUTS **55**
N. OF NPN OPTOCOUPLED INPUT LINES **3**
N. OF OPTOCOUPLED NPN INPUTS **45, 55**
N. OF OUTPUT LINES **19, 27, 37**
N. OF PNP OPTOCOUPLED INPUT LINES **11**
N. OF POWER OUTPUTS **45**
N. OF TTL INPUT LINES **19, 27, 37**
N. OF TTL SIGNALS **3, 11**
NPN OPTO INPUTS POWER SUPPLY **46**

O

OBI N8 3
OBI P8 11
ON BOARD JUMPERS 8, 16, 24, 35, 42, 53
OUTPUT CURRENT ON EACH SIGNAL 46

P

POWER SUPPLY VOLTAGE 37
PULL-DOWN RESISTORS 8, 16, 24, 42
PULL-UP RESISTORS 8, 16, 24, 42

R

RBO 08 19
RBO 16 27
RELATIVE HUMIDITY 3, 11, 19, 27, 37, 45, 55
RELAYS POWER SUPPLY 46

S

SIZE 3, 11, 19, 27, 37, 45, 55
SOFTWARE DESCRIPTION 10, 18, 26, 36, 44, 54, 63

T

TBO 08 37
TEMPERATURE RANGE 3, 11, 19, 27, 37, 45, 55

W

WEIGHT 3, 11, 19, 27, 37, 45, 55

X

XBI R4 45
XBI T4 55