

BASIC 324/320

rel. 3.3 and later

INTRODUCTION

BASIC 52 is a powerful software tool developed by **grifo**®, capable of managing a BASIC high level programming of all Intel 51 family based cards. It is a "romated" software that generates "romable" software in an easy to use environment; it also reduces the necessity of external hardware (in circuit emulator, EPROM programmer, etc.) and at the same time it speeds up the debugging phase of the User application program.

BASIC 52 is referred to generic software tools, but each card has a specific version of software associated to their hardware features; so for each card the name **BASIC 52** become BASIC followed by the card final name.

This documentation must be read as "additional up-grade" **BASIC 52** manual.

BASIC 52 FOR GPC® 324 WITH DALLAS DS80C320 = BASIC 324/320

Here follows a summary of the differences between original MCS BASIC 52 and **BASIC 324/320**:

Removed commands

LIST#
FPROG
FPROG1
FPROG2
FPROG3
FPROG4
FPROG5
FPROG6

Removed instructions

BAUD
PRINT#
PH0.#
PH1.#
PWM

Removed operators

None

Added commands

ERASE

->

Deletes EEPROM content removing all the application program saved in with command PROG, PROG1, ..., PROG6.

Function

Added instructions

BY_EE

->

Performs a byte read or write operation on serial EEPROM.

BL_EE

->

Performs a data block read or write operation on serial EEPROM.

RW_SFR

->

Performs SFR read or write operation.

COM2

->

Manages INPUT on the second serial line.

PRINT@

->

Manages OUTPUT on the second serial line.

Added instructions
Function

P8255	->	Manages 82C55 initialization.
DISPLAY	->	Selects and initializes a display.
KEYB	->	Manages all the keyboard operations.
Output console redirection	->	Manages LCD or fluorescent display through BASIC high level instructions.

Added operators
Function

None	->	-
------	----	---

AUTORUN AND DEBUG MODE

For executing an application program in AUTORUN mode (automatic start after power on or reset), the User must **connect** the **Jumper J1**. While if **BASIC 324/320** must be executed when an AUTORUN condition is present, the User must **disconnect** the **Jumper J1**. For summarizing:

JUMPER J1 DISCONNECTED:	DEBUG mode.
JUMPER J1 CONNECTED:	RUN mode.

DEBUG mode is really interesting when, for example, a working system must be changed or updated: in this condition the User can simply connect target card to P.C., selecting the DEBUG mode and with **BASIC 324/320**, loading, testing and saving a new application program and then set again RUN mode. No hardware must be changed on target card, being possible to make these operations directly "on the field". For setting a program in AUTORUN mode follow these steps:

- Select DEBUG mode (Disconnect J1).
- Type: ERASE <enter>.
- Load the program in memory.
- Type: PROG <enter>
- Type: PROG4 <enter>

ADDITIONAL INSTRUCTION SYNTAX DESCRIPTION

To **BASIC 324/320** have been added some new procedures which allow management of **GPC® 552** on board hardware. Some external SRAM locations are used for parameters interchange between application program and added procedures and for the same procedures own requirements. This SRAM area is located in **07E00H÷07FFF** addresses range. Before writing an application program, that uses the additional procedures, the User must absolutely execute the command: **MTOP=07DFH** to avoid overlap between interchange area and **BASIC 324/320** work SRAM area.

The User must not change internal ram locations 018H÷021H because implement the new tokens. The next pages describes additional procedures with information about parameters and execution.

SERIAL EEPROM BYTE READ/WRITE PROCEDURE

Syntax: BY_EE <expr1>, <expr2>, <expr3>

Procedure description:

It performs a byte read or write operation on serial EEPROM (IC9) at a specified address. The User must remember that in read procedure the <expr3> parameter must be given even if it has no meaning.

Parameters description:

<expr1> --> 0 = Reading of a byte.
 --> 1 = Writing of a byte.
 <expr2> --> Location address (0÷<last device address>).
 <expr3> --> Byte to write (0÷255).

Serial EEPROM addresses range:

0030H÷00FFH -> selection EEPROM 24c02 (IC9)
 0030H÷01FFH -> selection EEPROM 24c04 (IC9)
 0030H÷03FFH -> selection EEPROM 24c08 (IC9)
 0030H÷07FFH -> selection EEPROM 24c016 (IC9)

Procedure output description (values that must extract through POP ... instruction):

OUTPUT WRITING: 0 --> Writing OK.
 1 --> Wrong parameters.
 2 --> The device is not recognized.

OUTPUT READING: 0÷255 --> Reading OK.
 257 --> Wrong parameters.
 258 --> The device is not recognized.

Examples:

```
0   REM ***** Demo for WRITING the byte 85 at address 100 of serial EEPROM
10  BY_EE 1,100,85 : REM It selects WRITE operation
20  POP A : REM It reads the operation result
```

```
0   REM ***** Demo for READING the byte at address 100 of serial EEPROM
10  BY_EE 0,100,0 : REM It selects READ operation
20  POP A : REM It reads the value and the operation result
```

SERIAL EEPROM DATA BLOCK READ/WRITE PROCEDURE

Syntax: BL_EE <expr1>, <expr2>, <expr3>

Procedure description:

It performs a data block read or write operation at a specified address, on serial EEPROM (IC9). The W/R data buffer is located in EXTERNAL SRAM in **07E00H÷07EFF** addresses range.

Parameters description:

<expr1> --> 0 = Reading of a data block.
--> 1= Writing of a data block.
<expr2> --> Initial location address (0÷<last device address>).
<expr3> --> Number of bytes to write or read (1÷255).

Serial EEPROM addresses range:

0030H÷00FFH -> selection EEPROM 24c02 (IC9)
0030H÷01FFH -> selection EEPROM 24c04 (IC9)
0030H÷03FFH -> selection EEPROM 24c08 (IC9)
0030H÷07FFH -> selection EEPROM 24c016 (IC9)

Procedure output description (values that must extract through POP ... instruction):

OUTPUT: 0 --> Reading/Writing OK.
1 --> Wrong parameters.
2 --> The device is not recognized.

Examples:

```
0 REM ***** Demo for WRITING 3 bytes starting from address 100 of serial EEPROM.
10 XBY(07E00H)=1
20 XBY(07E01H)=2
30 XBY(07E02H)=3
10 BL_EE 1,100,3 : REM Performs block write.
20 POP A : REM It reads the operation result.
```

```
0 REM ***** Demo for READING 3 bytes starting from address 100 of serial EEPROM.
10 XBY(07E00H)=0 : REM Sets reception buffer content to zero.
20 XBY(07E01H)=0
30 XBY(07E02H)=0
40 BL_EE 0,100,3 : REM Performs block read.
50 POP A : REM It reads the operation result.
60 FOR I=07E00H TO 07E02H : REM Prints Reception buffer content.
70 PRINT XBY(I),
80 NEXT I
```

SPECIAL FUNCTION REGISTERS READ OR WRITE PROCEDURE

Syntax: RW_SFR <expr1>, <expr2>, <expr3>

Procedure description:

It performs a special function register (SFR) read or write operations.

The User should remember that in "read procedure" the <expr3> parameter must be given even if it has no meaning. The SFR identification byte is a numeric code, with the following meaning:

SFR NAME	IDENTIFICATION SFR BYTE
DPL1	0
DPH1	1
DPS	2
CKCON	3
EXIF	4
SCON1	5
SBUF1	6
TA	7
WDCON	8
EIE	9
EIP	10

Parameters description:

<expr1> --> 0÷1 = R/W selection byte (0=Reading; 1=Writing).
 <expr2> --> 0÷10 = SFR identification byte.
 <expr3> --> 0÷255 = Byte to write (must be provided also for writing operations).

Procedure output description (values that must extract through POP ... instruction):

OUTPUT WRITING: 0 = Writing OK.
 65535 = Wrong parameters.

OUTPUT READING: 0÷255 = Read value.
 65535 = Wrong parameters.

Examples:

```
0   REM ***** Demo for writing byte 85 in DPL1
10  RW_SFR 1,0,85 : POP A
```

```
0   REM ***** Demo for DPS reading
10  RW_SFR 0,2,0 : POP A
20  IF A<>65535 THEN ? "DPS= ",A
```

PROCEDURE FOR 82C55 INITIALIZATION USED IN REDIRECTION OF INPUT AND OUTPUT

Syntax: P8255 <expr>

Procedure description:

This instruction initializes the 82c55 for managing the **QTP24P** operator panel. Please remember that this function must be called only once before using operator panel management instructions like KEYB, DISPLAY, UO1.

Parameters description:

<expr> --> 0 = PORTB in INPUT.
 --> 1 = PORTB in OUTPUT.

Examples:

```
0   REM ***** Demo for managing QTP 24P.
5   P8255 0 : REM 82c55 intiialized for PORTB in INPUT.
7   XBY(0FFFCH)=XBY(0FFFCH).OR.1 : REM PULL-UP actived on the lines.
10  DISPLAY 5 : REM Display LCD20x4 selected.
20  UO1 : REM OUTPUT redirection enabled
30  PRINT "GRIFO", : REM Prints a string on the display
40  UO0 : REM OUTPUT redirection disabled
```

NOTE

The card **GPC® 324** in not provided with an on board 82c55 which is essential to interface an operator panel **QTP 24P**. The instructions specific to manage the 82c55 (P8255, KEYB, DISPLAY, UO1) have been implemented anyway.

Their purpose is to drive an external PPI 82c55 mapped at the following addresses:

82c55 registers		Addresses μ P	Address mapped on ABACO® I/O BUS
PORTA	-->	0FF7CH	07CH
PORTB	-->	0FF7DH	07DH
PORTC	-->	0FF7EH	07EH
CONTROL	-->	0FF7FH	07FH

For further informations about how to connect the 82c55 and its mapping logic please refer to the electric diagrams included in this manual.

The needed circuitry is provided by a **ETI 324** card, available from **grifo®**; so the PPI 82c55 I/O lines are made available on a standard connector designed for a direct connection to a **QTP 24P** operator panel.

KEYBOARD MANAGEMENT PROCEDURE

Syntax: KEYB <expr>

Procedure description:

It enables or disables the matrix keyboard scanning and reads the possible key pressed code.

This procedure can start or stop a periodic **QTP 24P** keyboard scanning, with debouncing on the pressed key, or it can return the pressed key code (0 if no key is pressed) through the stack. The keyboard managed by this procedure is a 4*6 matrix keyboard directly connected to connector **CN3** of **ETI 324** card driven by a **GPC® 324**:

	CN3-PIN 11 (PC.4)	CN3-PIN 12 (PC.5)	CN3-PIN 9 (PC.6)	CN3-PIN 10 (PC.7)
CN3-PIN 5 (PA.5)	68	67	66	65
CN3-PIN 6 (PA.4)	72	71	70	69
CN3-PIN 3 (PA.3)	76	75	74	73
CN3-PIN 4 (PA.2)	54	52	51	50
CN3-PIN 1 (PA.1)	13	48	57	56
CN3-PIN 2 (PA.0)	55	27	53	49

Parameters description:

<expr> --> 0 = Keyboard scanning OFF.
 --> 1 = Keyboard scanning ON.
 --> 2 = Return the pressed key code (0 if no key is pressed) through the stack.
 The keyboard scanning is enabled if it was OFF.

Procedure output description (values that must extract through POP ... instruction):

OUTPUT: 0 = No key pressed.
 nn = Pressed key code (refer to the terminal keys map).
 65535 = Wrong parameter.

Example:

In the following demo program, it is enabled the matrix keyboard scanning and a loop is performed. In this loop the pressed key is controlled and when the 48 key code is pressed, the loop is terminated and the keyboard scanning is disabled.

```

0   REM ***** Matrix keyboard example
10  KEYB 1 : POP A : REM It enables keyboard scanning
20  KEYB 2 : POP A : REM It reads the key pressed code
30  IF A<>48 THEN 20
40  KEYB 0 : POP A : REM It disables keyboard scanning
50  END
  
```

QTP 24P TERMINAL KEYS MAP

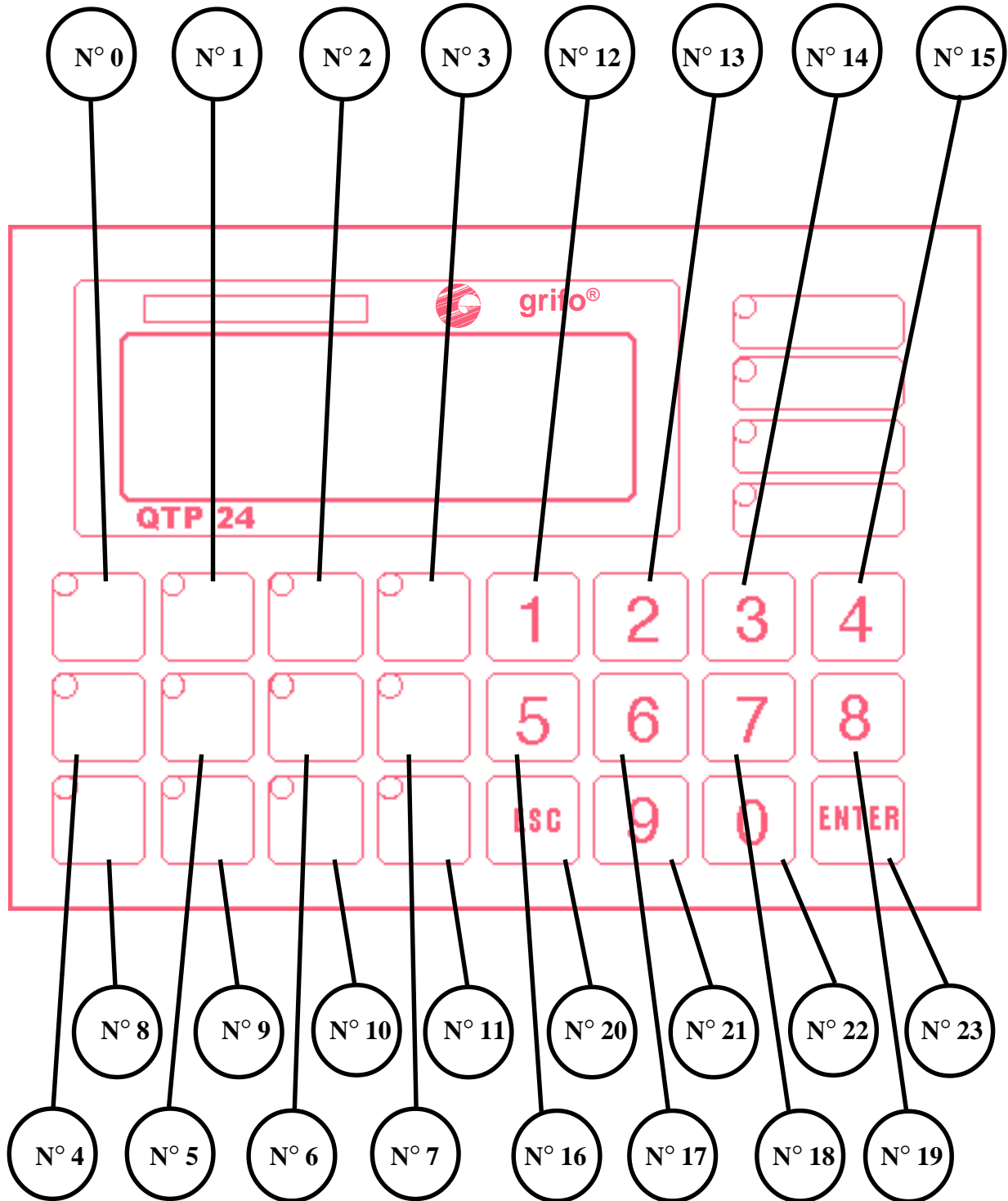

KEYS CODES ON QTP 24P

TASTO N°	CODICE	CODICE HEX	MNEMONICO
0	65	41	A
1	66	42	B
2	67	43	C
3	68	44	D
4	69	45	E
5	70	46	F
6	71	47	G
7	72	48	H
8	73	49	I
9	74	4A	J
10	75	4B	K
11	76	4C	L
12	49	31	1
13	50	32	2
14	51	33	3
15	52	34	4
16	53	35	5
17	54	36	6
18	55	37	7
19	56	38	8
20	27	1B	ESC
21	57	39	9
22	48	30	0
23	13	0D	CR

QTP 24P LEDS MAP

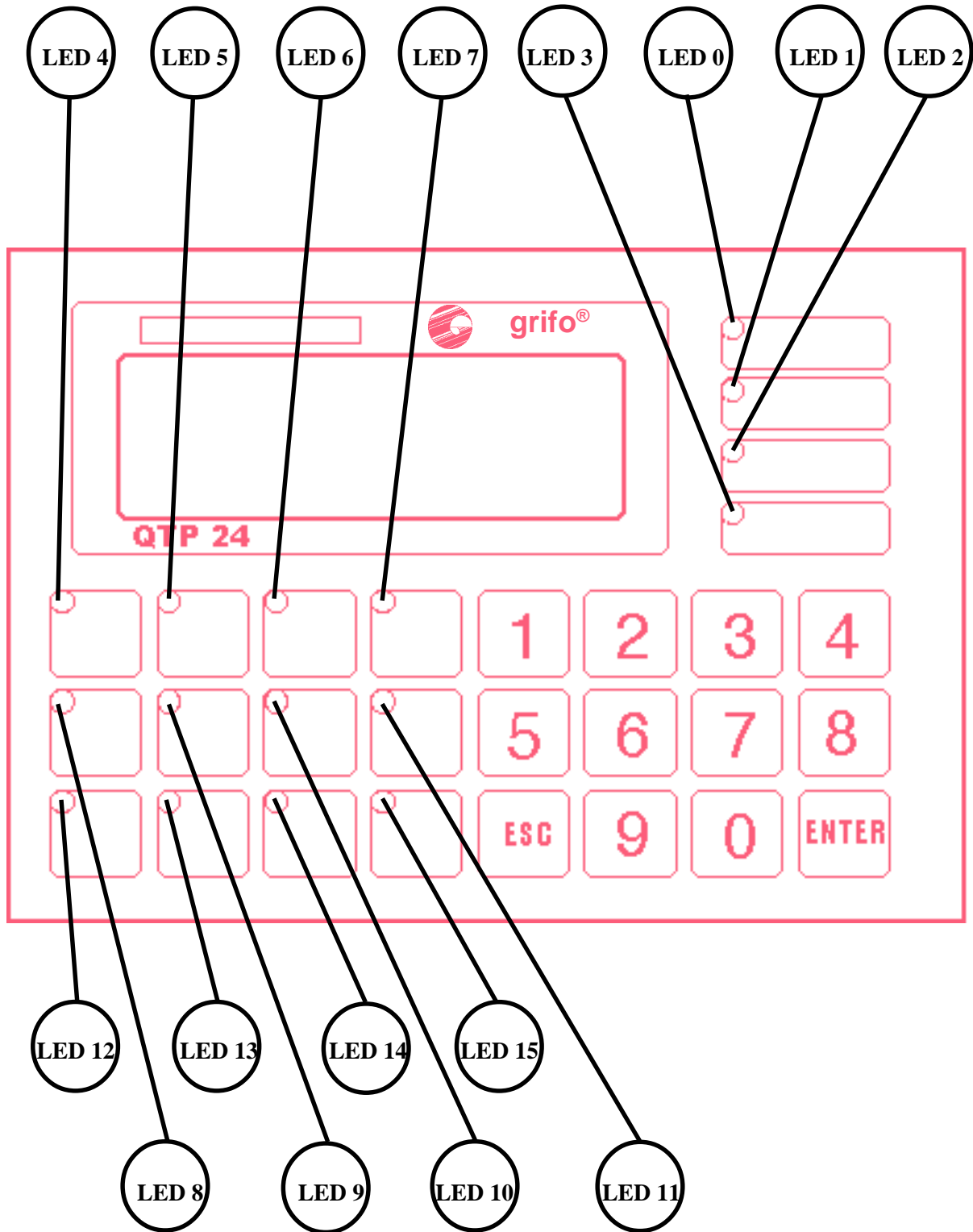

DISPLAY SELECTION AND INITIALIZATION PROCEDURE

Syntax: DISPLAY <expr>

Procedure description:

Initializes the selected display. Please remark before using output redirection (UO1) the User must invoke this function to select the display.

Parameters description:

<expr> --> 0 = FUTABA 20x2
1 = FUTABA 40x1
2 = FUTABA 40x2
3 = FUTABA 40x4
4 = LCD 20x2
5 = LCD 20x4
6 = LCD 40x1
7 = LCD 40x2
8 = LCD 40x4

Procedure output description (values that must extract through POP ... instruction):

OUTPUT: None.

Example:

```
5   P8255 0 : REM External 82C55 initialization for operator panel management.
10  DISPLAY 5 : REM Selects display LCD20x4.
20  UO1 : REM OUTPUT redirection enabled
30  PRINT "GRIFO", : REM Prints a string to the display
40  UO0 : REM OUTPUT redirection disabled
```

SECOND SERIAL LINE MANAGEMENT PROCEDURE

Syntax: COM2 <expr>

Procedure description:

This procedure manages all the operations on the second serial line (TXB=PIN 2 on CN3B; RXB=PIN 5 on CN3B). For the transmission on this line the User must use the PRINT@ ... instruction. If the second serial line management is active, the User can't use the TIMER 1 instructions because this timer is used as baud rate generator.

Parameters description:

<expr> --> 0 = It disables the second serial line
1 = It enables the software serial line at 1200 BAUD
2 = It enables the software serial line at 2400 BAUD
3 = It enables the software serial line at 4800 BAUD
4 = It enables the software serial line at 9600 BAUD
5 = It enables the software serial line at 19200 BAUD
6 = Character reception (non suspensive)

Procedure output description (values that must extract through POP ... instruction):

OUTPUT: 65535 = Wrong parameter.
0 = Operazione OK (if <expr>=0÷5).
256 = No character received (se <expr>=6).
0÷255 = Last character received (se <expr>=6).

Example:

```
0 REM *****Demo for second serial line management: the characters received on
1 REM ***** primary serial line are echoed to the second line and viceversa; exits
2 REM ***** when "F" is received.
10 COM2 5 : POP B : REM Second serial line actived at 19200 BAUD.
20 A=GET
30 IF A=0 THEN GOTO 70 : REM Has a character been received from serial A ?
40 IF A=70 THEN GOTO 110 : REM Is the character "F" ?
50 PRINT@ CHR(A), : REM Echo to second serial line.
60 GOTO 20
70 COM2 6 : POP A : REM Has a character been received from serial line B ?
80 IF A=256 THEN 20
90 PRINT CHR(A),
100 GOTO 20
110 COM2 0 : POP B : REM Disables second serial line.
120 END
```

USER OUTPUT REDIRECTION PROCEDURE

BASIC 324/320 includes specific software procedures to solve the User interface problems. In the standard industrial applications, the User interface is realized with displays and custom keyboards; so **BASIC 324/320** provides high level procedure for these components. Normally BASIC performs User interface or console operations through the target card serial line, but at the same time it has the possibility to redirect console operations to other hardware devices, thanks to specific software (for further information, please read UO0, UO1 instructions).

The User output can be redirected to fluorescent or LCD displays, simply using the PRINT instruction.

Example:

```
5   P8255 0 : REM External 82C55 initialization for operator panel management.
10  DISPLAY 5 : REM LCD20x4display selection.
20  UO1 : REM It enables output redirection.
30  PRINT "Hello", : REM It prints a string on the display.
40  PRINT "Grifo", : REM It prints a string on the display.
50  PRINT CHR(1), : REM Cursor in HOME position.
60  PRINT CHR(27), : PRINT CHR(80), : REM Cursor OFF.
70  UO0 : REM It disables output redirection.
```

QTP 24P shows on its display all the characters having a code in the range **32÷255 (20÷FF Hex)**; if it is sent a code not included in this range and this latter is not a command, it is ignored.

The characters of the codes in the range **32÷127 (20÷7F Hex)** correspond to the ones of the standard ASCII table, while characters associated to **128÷255 (80÷FF Hex)** codes, may show different symbols depending on the type of the display installed. This is the reason why it is opportune to refer to the Tables at the end of this documentation.

The character is visualized in the at-the-moment cursor position and this latter will go the the next position; if it is placed in the last character down on the right of the display, it will be placed to the Home position.

COMMANDS FOR CURSOR POSITIONING

CURSOR LEFT

Code: 21 (15Hex)
Mnemonic: NACK

The cursor is shifted of one position on the left without modifying the display contents. If the cursor is in Home position, it will be placed in the last character at the down-right position of the display.

CURSOR RIGHT

Code: 06
Mnemonic: ACK

The cursor is shifted of one position on the right.
If the cursor is placed on the last display character, down-right, it will be placed on the Home position.

CURSOR DOWN

Code: 10 (0A Hex)
Mnemonic: LF

The cursor will be placed on the next line of that one it is now but it will remain in the same column.
If the cursor is in the last display line, it will be placed at the first display line.

CURSOR UP

Code: 26 (1A Hex)
Mnemonic: SUB

The cursor will be placed in the previous line of that one it is now, but it will remain in the same column. If the cursor is on the first display line, it will be placed on the last display line.

HOME

Code: 01
Mnemonic: SOH

The cursor is on Home position i.e first line, first column of the display.

CARRIAGE RETURN

Code: **13** (**0D Hex**)
Mnemonic: **CR**

The cursor is placed at the beginning of the line where it is.

CARRIAGE RETURN+LINE FEED

Code: **29** (**1D Hex**)
Mnemonic: **GS**

The cursor is placed at the beginning of next line at which it was placed.
If the cursor is at the last display line, it will be placed at the beginning of the first line i.e Home position.

CURSOR ABSOLUTE POSITIONING WITH 20H OFFSET

Code: **27 89 r c** (**1B 59 r c Hex**)
Mnemonic: **ESC Y ASCII(r) ASCII(c)**

The cursor is placed at the absolute point indicated through "r" and "c".
These codes are referred to line and column values of the display at which the **32 (20 Hex)** offset must be add. If, for example, you wish to place the cursor at Home position (0 line, 0 column) the next sequence is necessary **27 89 32 32**.
If line and column values are not compatible to the installed display, that command is ignored.

COMMANDS FOR CHARACTERS ERASURE

BACKSPACE

Code: **08**
Mnemonic: **BS**

The cursor shifts a character on the left by erasing the contents of the reached cell. If the cursor is at Home position, the character placed in the last cell, down- on the right of the display, will be erased.

CLEAR PAGE

Code: **12** **(0C Hex)**
Mnemonic: **FF**

Complete erasure of the display and the cursor returns to Home position.

CLEAR LINE

Code: **25** **(19 Hex)**
Mnemonic: **EM**

The complete line where cursor is placed is erased and then the cursor goes at the beginning of the said line.

CLEAR END OF LINE

Code: **27 75** **(1B 4B Hex)**
Mnemonic: **ESC K**

All characters on the line where the cursor is placed are erased starting from cursor position up to the end of the line.

The cursor stays on the position as it was when **Clear End of Line** code arrives.

If, for example, the cursor is at the beginning of a display line, the complete line will be erased.

CLEAR END OF PAGE

Code: **27 107** **(1B 6B Hex)**
Mnemonic: **ESC k**

All characters starting from the Cursor point up to the end of the display, are erased. The cursor stays in the same position as it was before the **Clear end of Page** code arrival. If, for example, the cursor is at Home position, the display will be completely erased.

COMMANDS FOR CURSOR ATTRIBUTES MANAGEMENT

CURSOR OFF

Code: 27 80 (1B 50Hex)
Mnemonic: ESC P

The cursor is not active and it is not more visible.

STATIC CURSOR ON

Code: 27 79 (1B 4F Hex)
Mnemonic: ESC O

The cursor is started so it is visible. Now it is a not blinking line placed under the char.

Note: this command is not available if **Futaba 40x4** display is installed.

BLINKING "UNDERLINE" CURSOR

Code: 27 77 (1B 4D Hex)
Mnemonic: ESC M

The cursor is started so it is visible. Now it is a blinking line placed under the char.

Note: This command is available only for **Futaba** displays : **20x2** and **40x1** type.

BLINKING "BLOCK" CURSOR

Code: 27 81 (1B 51 Hex)
Mnemonic: ESC Q

The cursor is started so it is visible. Now it is a blinking rectangular form and it is alternatively visualized with the char put on the same.

Note: This command is available only for **LCD** displays otherwise is ignored

COMMANDS FOR LEDS MANAGEMENT

LED ACTIVATION

Code: 27 50 n.LED Attr. (1B 32 n.LED Attr. Hex)
Mnemonic: ESC 2 ASCII(n.LED) ASCII(Attr.)

The LED shown in "n.LED" with the specified attribute in "Attr." is started.
If you use the **QTP 24P** card LEDs numbers are included in a range of **0÷15** as shown in the picture of the card.

The attributes available are as follows:

0	<i>Not enabled LED</i>
255 (FF Hex)	<i>Enabled LED</i>
85 (55Hex)	<i>Blinking LED</i>

ex. If you wish to enable LED n.5 with blinking attribute, the following sequence has to be sent: **27 50 5 85**.

If the parameter with LED number or that one with the attribute, it is not valid, the command is ignored.

LEDS MASK ACTIVATION

Code: 27 52 byte1 byte2 byte3 (1B 34 byte1 byte2 byte3 Hex)
Mnemonic: ESC 4 ASCII(byte1) ASCII(byte2) ASCII(byte3)

All **QTP 24P** LEDs are contemporarily managed as indicated in "byte1", "byte2" and "byte3" following this code:

byte1 (bit 0...7)	LED 0...LED 7
byte2 (bit 0...7)	LED 8...LED 15
byte3 (bit 0...5)	Reserved

If a bit is placed in 0 position, the correspondent LED is OFF, viceversa it will be ON if the correspondent bit is on 1 position.

If there are some LEDs having the blinking attribute, this latter will be disabled.

For **QTP 24P** the "byte3" must be always sent even if it has no meaning for running the 16 LEDs of the said terminal.

COMMANDS FOR KEYBOARD MANAGEMENT

KEY RECONFIGURATION

Code: **27 55 key no. code (1B 37 key no. code Hex)**
Mnemonic: **ESC 7 ASCII(key no.) ASCII(code)**

When the selected key is reconfigured, each time it is pressed, the card will send the new specified code in serial mode. The number of the key to be reconfigured is obtainable by looking at the **QTP 24P** picture and it must be included in a range of **0÷23 (0÷17 Hex)** if this is not done the command is ignored. The code value can vary in a range of **0÷254 (0÷FE Hex)** as the **255 value (FF Hex)** indicates that the key must be disabled so when it is pressed the card will not send any codes.

P.S.

The said command needs a data writing on the on-board EEPROM so before executing it, it is better to be sure that the card is ready for a new writing on such device otherwise the command will be ignored.

BXC51 COMPILER REL. 5.0 USE

BXC51 compiler Rel. 5.0 is a software tools used to compile a **BASIC 52** source program obtaining a directly executable code for the target card. In this way the application program execution speed is notably incremented, in fact the program is not interpreted by **BASIC 52**, but directly executed by microprocessor.

BXC51 can be used with the **BASIC 324/320** new features, typing some options on the command line as described below:

BXC51 -2 -b<BAUD> -c7F00 -u7DFF -bCRUNxxyy <Nome file> (SRAM=32K)

CRUNxxyy.BXL is a library delivered by grifo® where xx indicates the crystal frequency and yy is the version number. This library is supplied with BXC51 package.

The option -b<BAUD> informs the compiler that automatic baud rate search routine must not be inserted in the generated code and it must initialize serial line with a fixed baud rate = BAUD. The allowed value for BAUD parameter are: 1200, 2400, 4800, 9600, 19200.

Please remark that if the crystal frequency is 22118400 Hz the real baud rate will be twice the declared baud rate. For example:if the declared baud rate is 19200 (-b19200) then the real baud rate will be 38400 BAUD.

If the frequency of the on board crystal is not multiple of 11059200 Hz, the option -b<BAUD> has the only effect to avoid to generate the code for automatic baud rate detection.

Moreover to set correctly the desired baud rate, in the BASIC source program must be added the instructions to set directly the internal microprocessor registers. Here follows an example for a card running at 14.7456 MHz:

```
0   REM ***** Original source program
10  PRINT "Hello word"

0   REM ***** Source program modified for BXC51 compiler
5   TIMER2=0FFF4H : RCAP2=0FFF4H : REM Baud=38400.
10  PRINT "Hello word"
```

For further information on the other **BXC51** command line options please refer to BXC51 documentation.

QTP 24P COMMAND CODES SUMMARY TABLE

COMMAND	CODE	HEX CODE	MNEMONIC
HOME	01	01	SOH
CURSOR LEFT	21	15	NACK
CURSOR RIGHT	06	06	ACK
CURSOR DOWN	10	0A	LF
CURSOR UP	26	1A	SUB
CARRIAGE RETURN	13	0D	CR
CR+LF	29	1D	GS
Cursor absolute positioning with 20H OFFSET	27 89 r c	1B 59 r c	ESC Y ASCII(r) ASCII(c)
BACKSPACE	08	08	BS
CLEAR PAGE	12	0C	FF
CLEAR LINE	25	19	EM
CLEAR END OF LINE	27 75	1B 4B	ESC K
CLEAR END OF PAGE	27 107	1B 6B	ESC k
Cursor OFF	27 80	1B 50	ESC P
Static cursor ON	27 79	1B 4F	ESC O
Blinking "UNDERLINE" cursor	27 77	1B 4D	ESC M
Blinking "BLOCK" cursor	27 81	1B 51	ESC Q
LED activation	27 50 n.LED Attr.	1B 32 n.LED Attr.	ESC 2 ASCII(n.LED) ASCII(Attr.)
LEDS mask activation	27 52 byte1 byte2 byte3	1B 34 byte1 byte2 byte3	ESC 4 ASCII(byte1) ASCII(byte2) ASCII(byte3)
Key reconfiguration	27 55 key no. cod.	1B 37 key no. cod.	ESC 7 ASCII(key no.) ASCII(cod.)

DISPLAYS CHARACTERS TABLES

		Higher 4-bit (D4 to D7) of Character Code (Hexadecimal)																
		0	1	2	3	4	5	6	7	8	9	A	B	C	D	E	F	
Lower 4-bit (D0 to D3) of Character Code (Hexadecimal)	0	CG RAM (1)	0	1	2	3	4	5	6	7	8	9	A	B	C	D	E	F
	1	CG RAM (2)	1	2	3	4	5	6	7	8	9	A	B	C	D	E	F	
	2	CG RAM (3)	2	3	4	5	6	7	8	9	A	B	C	D	E	F		
	3	CG RAM (4)	3	4	5	6	7	8	9	A	B	C	D	E	F			
	4	CG RAM (5)	4	5	6	7	8	9	A	B	C	D	E	F				
	5	CG RAM (6)	5	6	7	8	9	A	B	C	D	E	F					
	6	CG RAM (7)	6	7	8	9	A	B	C	D	E	F						
	7	CG RAM (8)	7	8	9	A	B	C	D	E	F							
	8	CG RAM (1)	8	9	A	B	C	D	E	F								
	9	CG RAM (2)	9	A	B	C	D	E	F									
	A	CG RAM (3)	A	B	C	D	E	F										
	B	CG RAM (4)	B	C	D	E	F											
	C	CG RAM (5)	C	D	E	F												
	D	CG RAM (6)	D	E	F													
	E	CG RAM (7)	E	F														
	F	CG RAM (8)	F															

LCD 20x2 CHARACTERS TABLE



LOWER 4-BIT	MSB	0000	0010	0011	0100	0101	0110	0111	1000	1001	1010	1011	1100	1101	1110	1111
LSB XXXX0000	(E)	0	1	2	3	4	5	6	7	8	9	A	B	C	D	E
XXXX0001	(F)	!	@	#	\$	%	&	'	()	*	+	=	>	?	~
XXXX0010	(G)	0	1	2	3	4	5	6	7	8	9	A	B	C	D	E
XXXX0011	(H)	0	1	2	3	4	5	6	7	8	9	A	B	C	D	E
XXXX0100	(I)	0	1	2	3	4	5	6	7	8	9	A	B	C	D	E
XXXX0101	(J)	0	1	2	3	4	5	6	7	8	9	A	B	C	D	E
XXXX0110	(K)	0	1	2	3	4	5	6	7	8	9	A	B	C	D	E
XXXX0111	(L)	0	1	2	3	4	5	6	7	8	9	A	B	C	D	E
XXXX1000	(M)	0	1	2	3	4	5	6	7	8	9	A	B	C	D	E
XXXX1001	(N)	0	1	2	3	4	5	6	7	8	9	A	B	C	D	E
XXXX1010	(O)	0	1	2	3	4	5	6	7	8	9	A	B	C	D	E
XXXX1011	(P)	0	1	2	3	4	5	6	7	8	9	A	B	C	D	E
XXXX1100	(Q)	0	1	2	3	4	5	6	7	8	9	A	B	C	D	E
XXXX1101	(R)	0	1	2	3	4	5	6	7	8	9	A	B	C	D	E
XXXX1110	(S)	0	1	2	3	4	5	6	7	8	9	A	B	C	D	E
XXXX1111	(T)	0	1	2	3	4	5	6	7	8	9	A	B	C	D	E

LCD 20x4 AND 40x2 CHARACTERS TABLE



LOWER 4-BIT HEXADECIMAL

Upper 4 bits \ Lower 4 bits	0000 (0)	0010 (2)	0011 (3)	0100 (4)	0101 (5)	0110 (6)	0111 (7)	1010 (A)	1011 (B)	1100 (C)	1101 (D)	1110 (E)	1111 (F)
xxxx0000 (0)	CG RAM (1)		0	1	2	3	4	5	6	7	8	9	A
xxxx0001 (1)	(2)	!	1	A	Q	a	q	2	3	4	5	6	7
xxxx0010 (2)	(3)	"	2	B	R	b	r	3	4	5	6	7	8
xxxx0011 (3)	(4)	#	3	C	S	c	s	4	5	6	7	8	9
xxxx0100 (4)	(5)	\$	4	D	T	d	t	5	6	7	8	9	A
xxxx0101 (5)	(6)	%	5	E	U	e	u	6	7	8	9	A	B
xxxx0110 (6)	(7)	&	6	F	V	f	v	7	8	9	A	B	C
xxxx0111 (7)	(8)	'	7	G	W	g	w	8	9	A	B	C	D
xxxx1000 (8)	(1)	(8	H	X	h	x	9	A	B	C	D	E
xxxx1001 (9)	(2))	9	I	Y	i	y	A	B	C	D	E	F
xxxx1010 (A)	(3)	*		J	Z	j	z	B	C	D	E	F	G
xxxx1011 (B)	(4)	+		K	[k	[C	D	E	F	G	H
xxxx1100 (C)	(5)	,	<	L]	l]	D	E	F	G	H	I
xxxx1101 (D)	(6)	-	=	M	^	m	^	E	F	G	H	I	J
xxxx1110 (E)	(7)	.	>	N	_	n	_	F	G	H	I	J	K
xxxx1111 (F)	(8)	/	?	O	~	o	~	G	H	I	J	K	L

LCD 40x1 AND 40x4 CHARACTERS TABLE



	D7	0	0	0	0	0	0	0	0	1	1	1	1	1	1	1	
	D6	0	0	0	0	1	1	1	1	0	0	0	0	1	1	1	
	D5	0	0	1	1	0	0	1	1	0	1	1	0	0	1	1	
	D4	0	1	0	1	0	1	0	1	0	1	0	1	0	1	1	
D D D D 3 2 1 0		0	1	2	3	4	5	6	7	8	9	A	B	C	D	E	F
0 0 0 0	0		DP		0	1	2	3	4	5	6	7	8	9	A	B	C
0 0 0 1	1			:	1	0	0	1	0	1	0	1	0	1	0	1	0
0 0 1 0	2			"	2	R	R	E	T	T	*	T	*	*	*	*	*
0 0 1 1	3			#	3	C	S	C	E	Δ	*	U	U	T	T	T	T
0 1 0 0	4	DIM	CU1	\$	4	D	T	Δ	t	0	U	.	U	T	T	T	T
0 1 0 1	5		CU2	%	5	E	U	E	U	U	U	*	.	*	*	U	U
0 1 1 0	6		CU3	&	6	F	U	f	U	0	U	U	U	U	U	U	U
0 1 1 1	7		DC	'	7	G	W	G	W	X	U	U	U	U	U	U	U
1 0 0 0	8	BS		©	8	H	X	H	X	P	U	U	U	U	U	U	U
1 0 0 1	9	HT		∞	9	I	Y	i	Y	U	U	U	U	U	U	U	U
1 0 1 0	A			*	A	J	Z	U	Z	P	U	U	U	U	U	U	U
1 0 1 1	B			+	B	K	T	K	0	0	U	U	U	U	U	U	U
1 1 0 0	C			.	C	L	#	I	I	T	U	U	U	U	U	U	U
1 1 0 1	D	CLR		-	D	M	I	m	U	U	U	U	U	U	U	U	U
1 1 1 0	E			.	E	N	∞	N	U	U	U	U	U	U	U	U	U
1 1 1 1	F	ALD	RST	/	F	O	_	O	■	U	U	U	U	U	U	U	U

FLUORESCENT 20x2 CHARACTERS TABLE



	D7	0	0	0	0	0	0	0	1	1	1	1	1	1	1		
	D6	0	0	0	0	1	1	1	1	0	0	0	1	1	1		
	D5	0	0	1	1	0	0	1	1	0	0	1	0	0	1		
	D4	0	1	0	1	0	1	0	1	0	1	0	1	0	1		
3210 0000		0	1	2	3	4	5	6	7	8	9	A	B	C	D	E	F
0000	0				0	0	P	`	P	A	E		-	9	E	0	P
0001	1				1	A	0	a	4	A	e	.	7	7	4	a	9
0010	2				"	2	B	R	b	r	A	E	F	I	W	X	E
0011	3				#	3	C	S	c	s	A	R	U	O	T	E	e
0100	4				\$	4	D	T	d	t	a	@	\	I	t	P	H
0101	5				%	5	E	U	e	u	E	O	.	7	7	1	0
0110	6				&	6	F	U	f	u	O	*	7	7	0	3	P
0111	7				'	7	G	W	g	w	@	o	7	7	7	7	3
1000	8				(8	H	X	h	x	@		4	0	7	U	J
1001	9)	9	I	Y	i	y	@	F	7	7	U	U	U
1010	A				*	A	J	Z	j	z	U	A	e	0	N	V	J
1011	B				+	B	K	I	k	I	U	A	7	7	0	7	A
1100	C				,	C	L	#	l	#	\	2	7	7	7	7	7
1101	D				-	D	M	I	m)	7	7	7	7	7	7	7
1110	E				.	E	N	^	n	7	7	7	7	7	7	7	7
1111	F				/	F	O	_	o	+	7	7	7	7	7	7	7

FLUORESCENT 20x4 CHARACTERS TABLE



	D7	0	0	0	0	0	0	0	0	0	0	0	0	0	0	0	0
	D6	0	0	0	0	1	1	1	1	1	1	1	1	1	1	1	1
	D5	0	0	1	1	0	0	1	1	0	0	1	1	0	0	1	1
	D4	0	1	0	1	0	1	0	1	0	1	0	1	0	1	0	1
0302D1D0		0	1	2	3	4	5	6	7	8	9	A	B	C	D	E	F
0 0 0 0	0	DP		0	0	P	'	P	0	E	0	0	0	0	0	0	0
0 0 0 1	1	DC1	!	1	A	0	a	g	0	0	0	0	0	0	0	0	0
0 0 1 0	2	DC2	"	2	B	R	B	r	0	0	0	0	0	0	0	0	0
0 0 1 1	3	DEF	#	3	0	S	c	s	0	0	0	0	0	0	0	0	0
0 1 0 0	4	DIM	+	4	0	T	a	t	0	0	0	0	0	0	0	0	0
0 1 0 1	5		2	5	E	U	e	u	0	0	0	0	0	0	0	0	0
0 1 1 0	6		0	6	F	V	A	v	0	0	0	0	0	0	0	0	0
0 1 1 1	7		'	7	0	W	a	w	0	0	0	0	0	0	0	0	0
1 0 0 0	8	BS	(8	H	X	H	x	0	0	0	0	0	0	0	0	0
1 0 0 1	9	HT)	9	I	V	i	v	0	0	0	0	0	0	0	0	0
1 0 1 0	A	LF	*	1	0	Z	i	z	0	0	0	0	0	0	0	0	0
1 0 1 1	B		+	1	K	K	0	0	0	0	0	0	0	0	0	0	0
1 1 0 0	C		,	<	L	\	l	\	0	0	0	0	0	0	0	0	0
1 1 0 1	D	CR	-	=	M	m	0	0	0	0	0	0	0	0	UF0	0	0
1 1 1 0	E		.	>	N	n	0	0	0	0	0	0	0	0	UF1	0	0
1 1 1 1	F	RST	/	?	0	_	0	0	0	0	0	0	0	0	UF2	0	0

FLUORESCENT 40x1 AND 40x2 CHARACTERS TABLE



	0000	0001	0010	0011	0100	0101	0110	0111	1000	1001	1010	1011	1100	1101	1110	1111
xxxx0000		DP		0	1	2	3	4	5	6	7	8	9	-	.	/
xxxx0001		DC1	:	!	@	#	\$	%	&	'	()	*	+	=	>
xxxx0010		DC2	"	#	\$	%	&	'	()	*	+	=	>	?	@
xxxx0011	DEF	DC3	#	\$	%	&	'	()	*	+	=	>	?	@	A
xxxx0100	DIM	DC4	@	1	2	3	4	5	6	7	8	9	-	.	/	:
xxxx0101		DC5	@	1	2	3	4	5	6	7	8	9	-	.	/	:
xxxx0110			0	1	2	3	4	5	6	7	8	9	-	.	/	:
xxxx0111			7	8	9	-	.	/	:	;	<	=	>	?	@	A
xxxx1000	BS		<	0	1	2	3	4	5	6	7	8	9	-	.	/
xxxx1001			>	0	1	2	3	4	5	6	7	8	9	-	.	/
xxxx1010		UP	*	;	<	=	>	?	@	A	B	C	D	E	F	G
xxxx1011	HM CLR	DWN	+	;	<	=	>	?	@	A	B	C	D	E	F	G
xxxx1100		RT	.	<	#											UF0
xxxx1101	CR LF	LT	—	—	—	—	—	—	—	—	—	—	—	—	—	UF1
xxxx1110			.	<	—	—	—	—	—	—	—	—	—	—	—	UF2
xxxx1111		RST	/	?	0	1	2	3	4	5	6	7	8	9	.	:

FLUORESCENT 40x4 CHARACTERS TABLE



ELECTRIC DIAGRAM

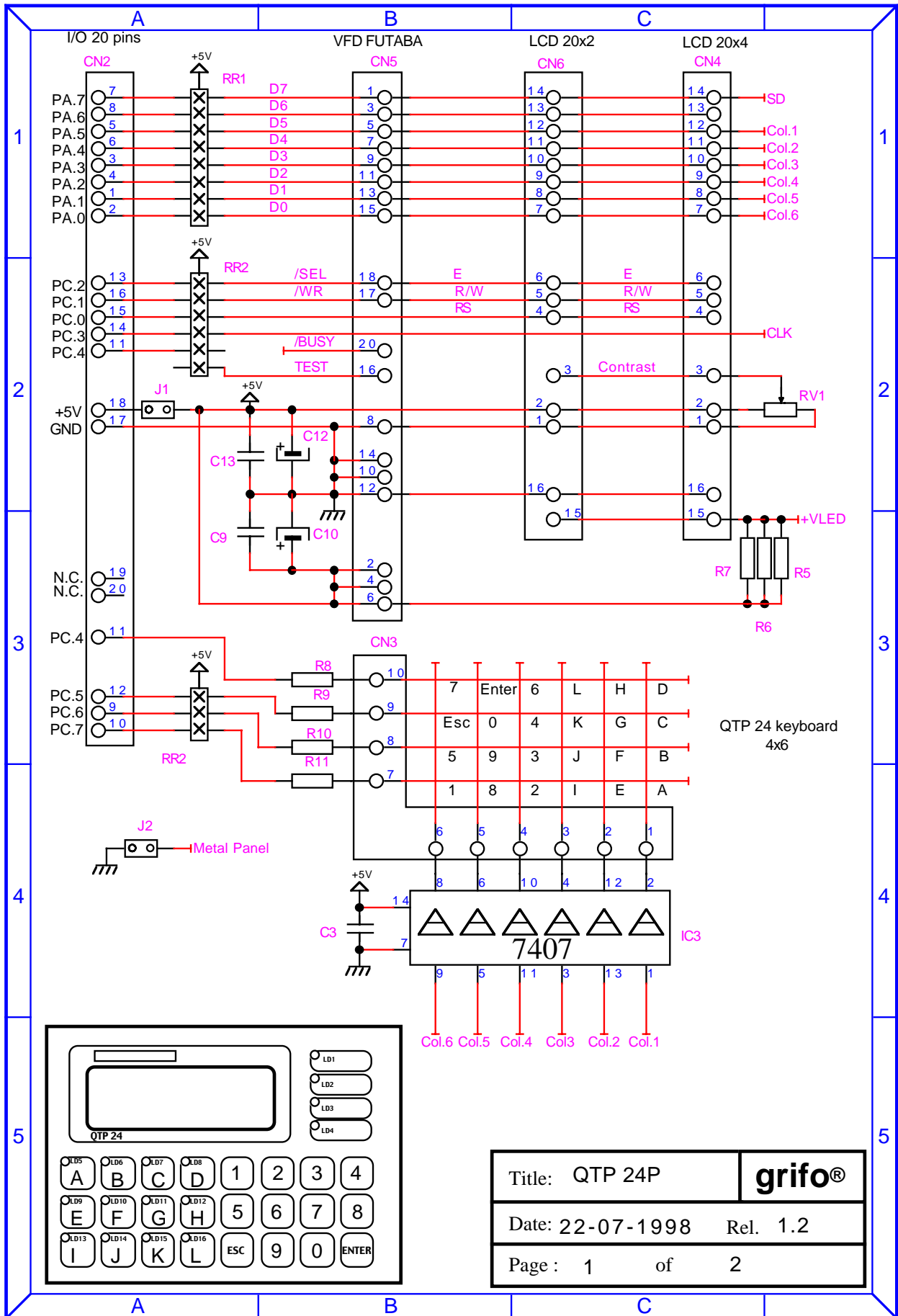

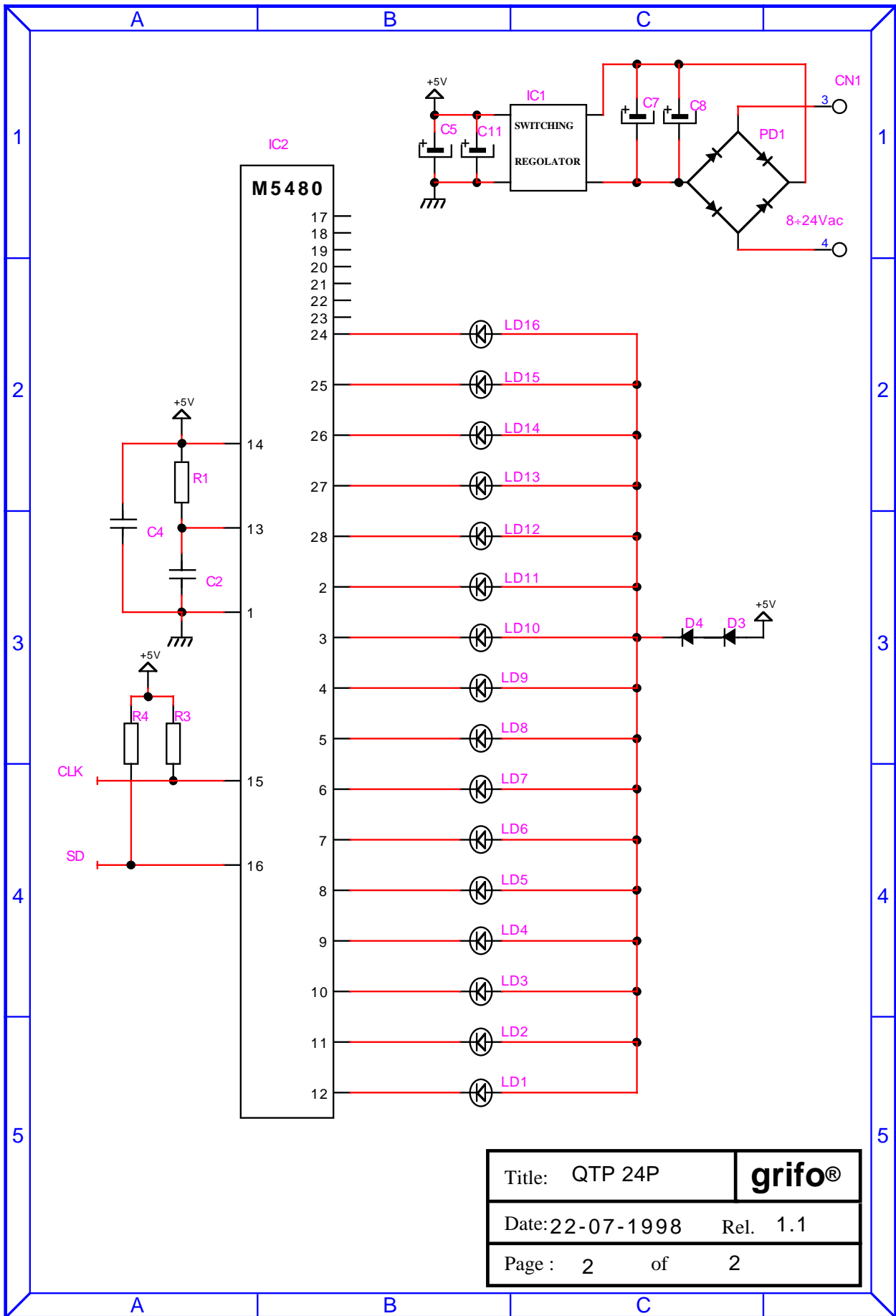

Title: QTP 24P	grifo®
Date: 22-07-1998	Rel. 1.1
Page : 2	of 2



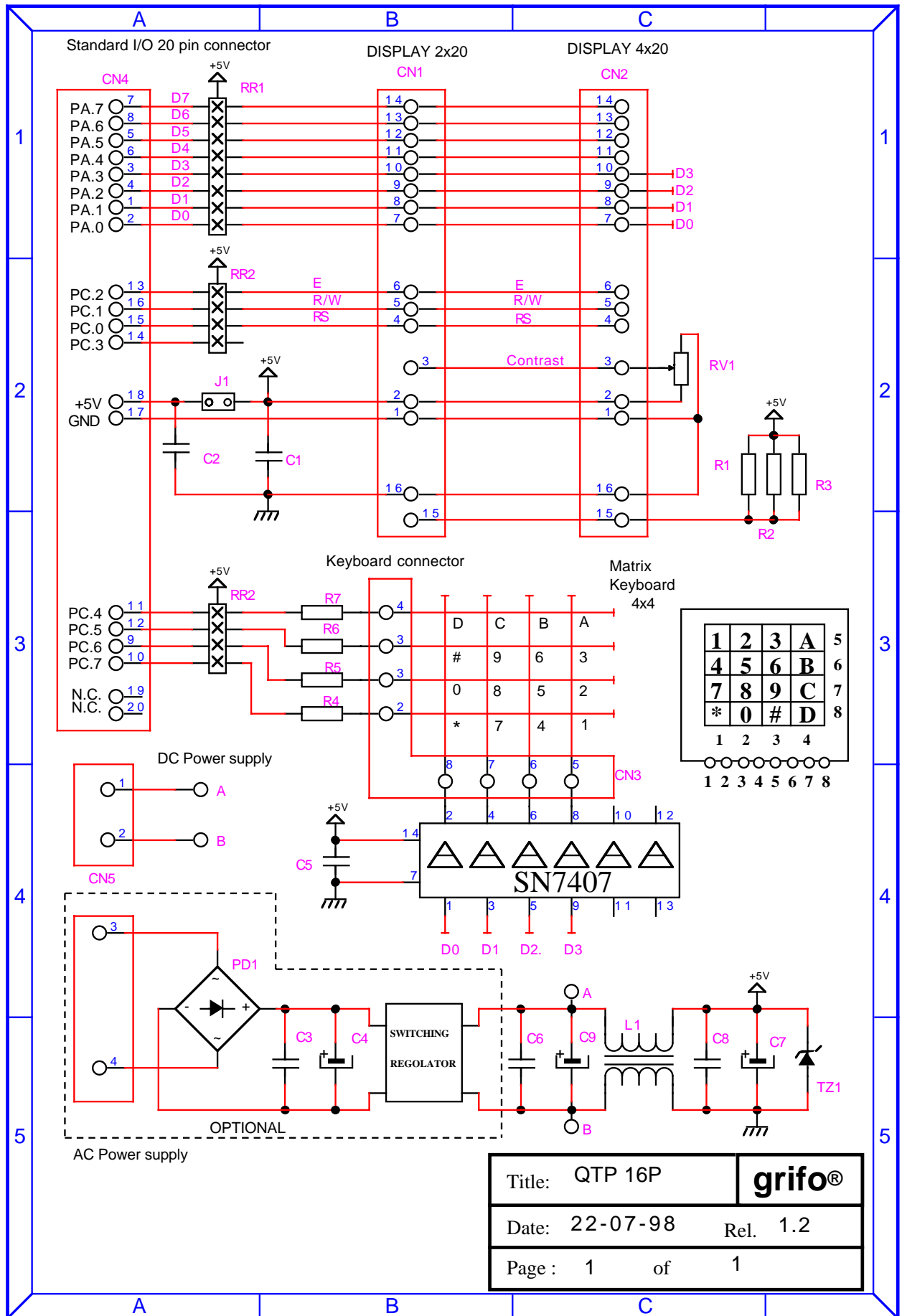

Title: QTP 16P	grifo®
Date: 22-07-98	Rel. 1.2
Page: 1	of 1



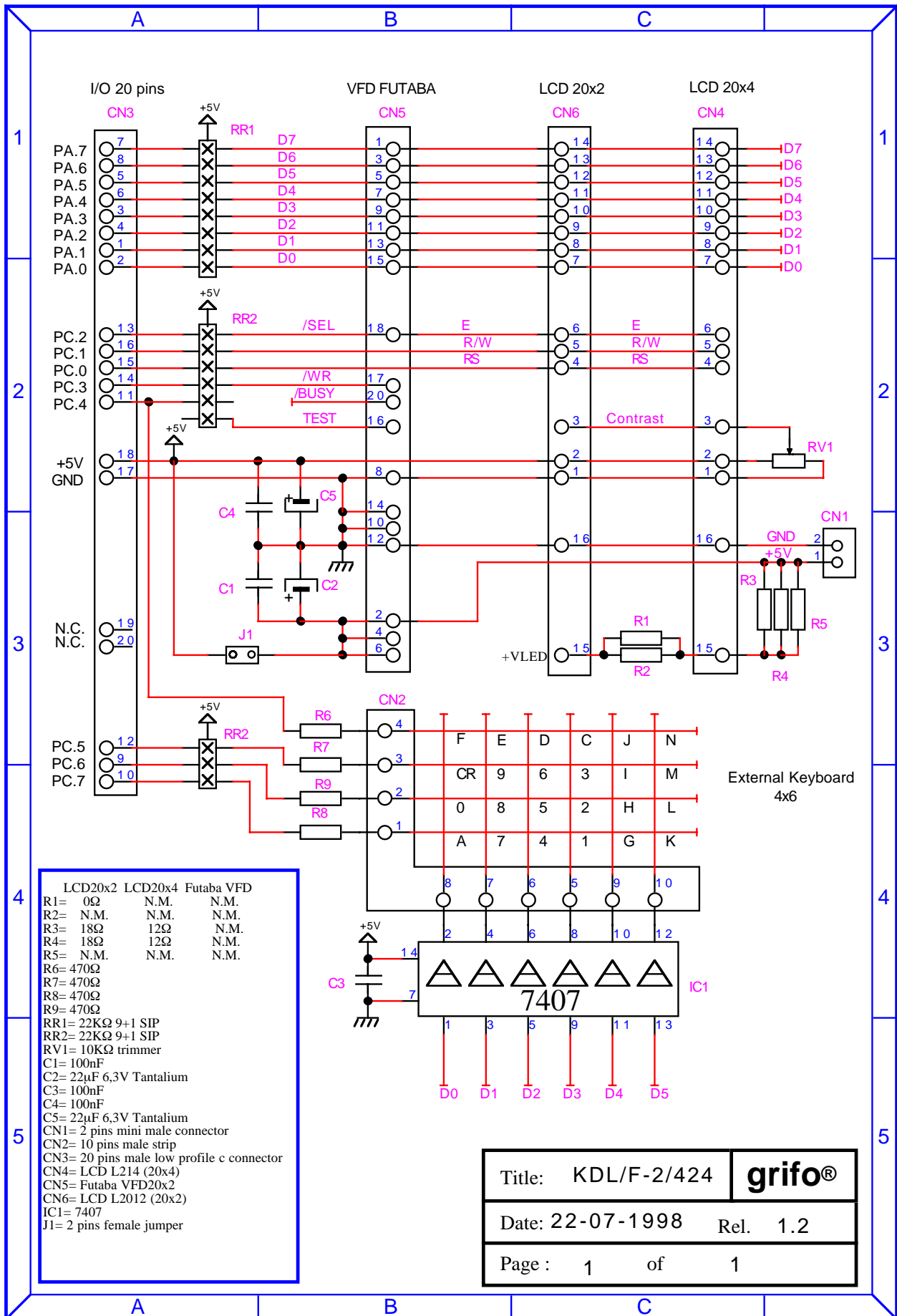

Title: KDL/F-2/424	grifo®
Date: 22-07-1998	Rel. 1.2
Page : 1	of 1



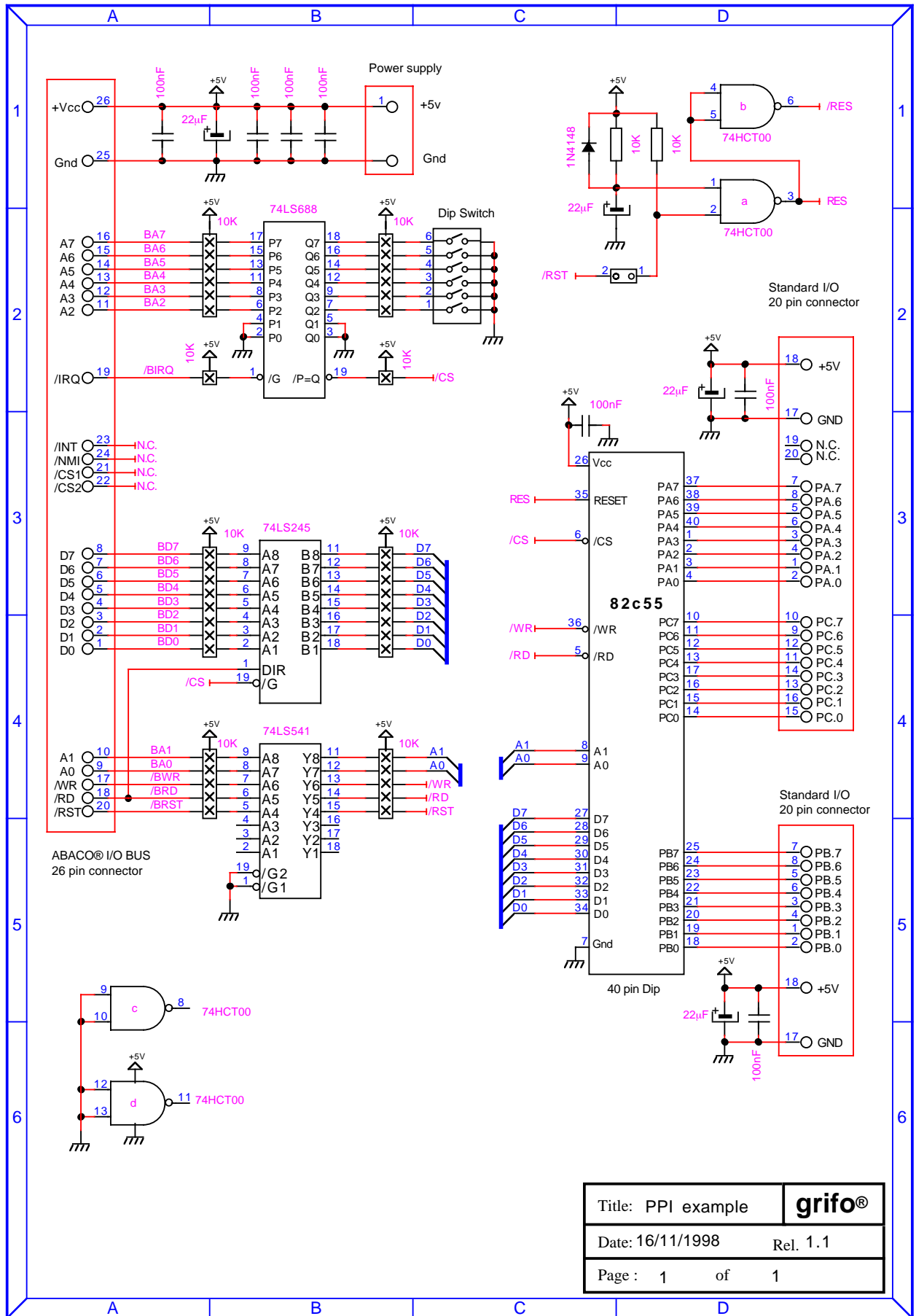

Title: PPI example	grifo®
Date: 16/11/1998	Rel. 1.1
Page : 1	of 1



