

CPR 16 - CPT 16

Coupled PNP Relays or Transistors

TECHNICAL MANUAL

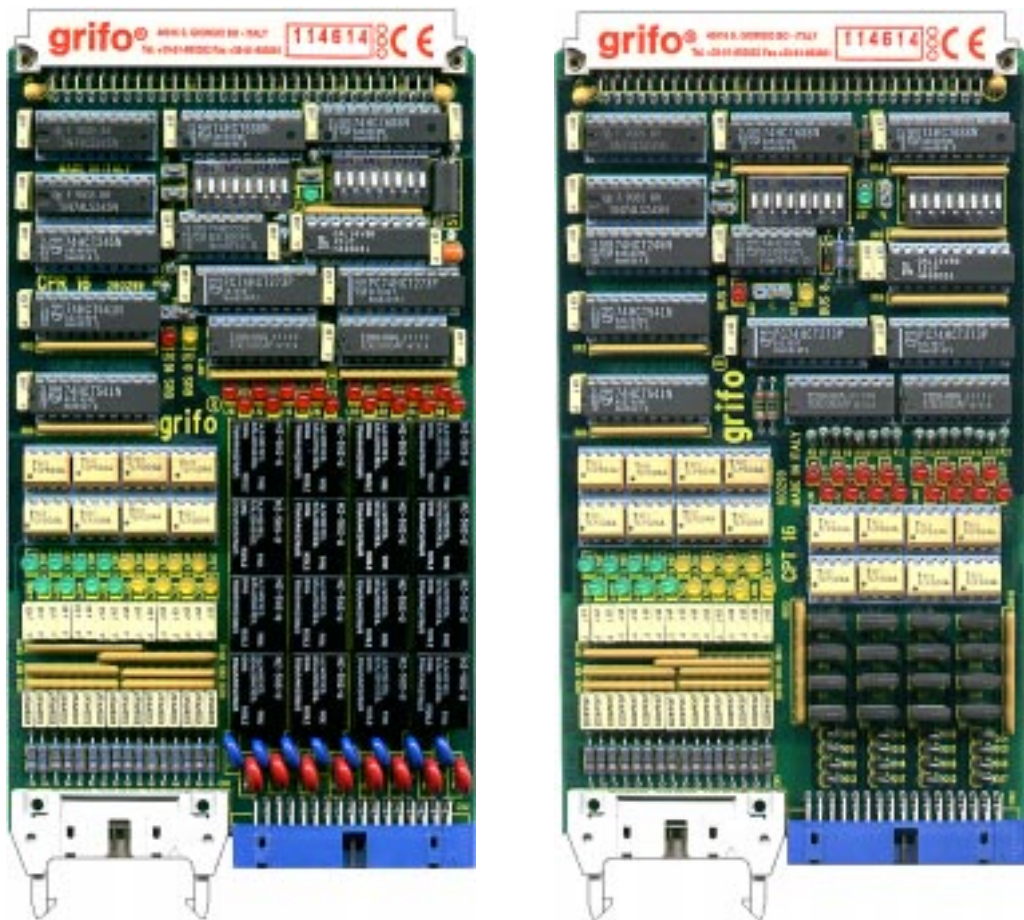

grifo[®]

ITALIAN TECHNOLOGY

Via dell' Artigiano, 8/6
40016 San Giorgio di Piano
(Bologna) ITALY

E-mail: grifo@grifo.it

<http://www.grifo.it>

Tel. +39 051 892.052 (a. r.)

<http://www.grifo.com>

FAX: +39 051 893.661

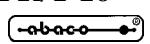

CPR/T 16 Edition 5.00 Rel. 22 September 2000

, GPC[®], grifo[®], are trade marks of grifo[®]

CPR 16 - CPT 16

Coupled PNP Relays or Transistors

TECHNICAL MANUAL

CPR 16

Single Europe format size 100x160 mm; BUS **ABACO**[®] industrial interface; 16 digital output signals with 1A 24V relays; MOV 24Vac transient suppressors on each relay; 16 LEDs to visualize the relays status; debouncing circuitry on each relays; 16 digital optocoupled PNP input signals with π filter on each input; 16 LEDs to visualize the logic status of each optocoupled input; I/O mapping selection through two on board Dip Switches; addressing space needed as low as 2 bytes contiguous; possibility to connect or disconnect the BUS /RESET signal; 20 pins standard input connector and 34 pins standard output connector; direct connection to interfaces for the external world **FBC 34**, **FBC L34**, etc.; possibility to have two different versions of power supply: **CPR 16** (multi supply version: 5Vdc and 12Vdc for relays) and **CPR 16.05** (single supply version: 5Vdc); power supply for optocoupled inputs 12÷24 Vdc.

CPT 16

Single Europe format size 100x160 mm; BUS **ABACO**[®] industrial interface; 16 digital output signals with 4A 45Vdc Darlington PNP open collector, without heat sink and provided with back EMF protection diode; 16 LEDs to visualize the transistors' status; anti-activation during the power on circuitry; 16 digital optocoupled PNP input signals with π filter on each input; 16 LEDs to visualize the logic status of each optocoupled input; I/O mapping selection through two on board Dip Switches; addressing space needed as low as 2 bytes contiguous; BUS data and addresses path can be 8 or 16 bits; BUS configuration visualized through 3 LEDs; possibility to connect or disconnect BUS /RESET signal; 20 pins standard input connector and 34 pins standard output connector; direct connection to interfaces for the external world **FBC 34**, **FBC L34**, etc.; unique power supply for the on board logic +5Vdc; power supply for optocoupled inputs 12÷24 Vdc.

grifo[®]

ITALIAN TECHNOLOGY

Via dell' Artigiano, 8/6
40016 San Giorgio di Piano
(Bologna) ITALY

E-mail: grifo@grifo.it

<http://www.grifo.it>

<http://www.grifo.com>

Tel. +39 051 892.052 (a. r.)

FAX: +39 051 893.661

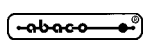

CPR/T 16 Edition 5.00 Rel. 22 September 2000

, GPC[®], grifo[®], are trade marks of grifo[®]

DOCUMENTATION COPYRIGHT BY grifo®, ALL RIGHTS RESERVED

No part of this document may be reproduced, transmitted, transcribed, stored in a retrieval system, or translated into any language or computer language, in any form or by any means, either electronic, mechanical, magnetic, optical, chemical, manual, or otherwise, without the prior written consent of **grifo®**.

IMPORTANT

Although all the information contained herein have been carefully verified, **grifo®** assumes no responsibility for errors that might appear in this document, or for damage to things or persons resulting from technical errors, omission and improper use of this manual and of the related software and hardware.

grifo® reserves the right to change the contents and form of this document, as well as the features and specification of its products at any time, without prior notice, to obtain always the best product.

For specific informations on the components mounted on the card, please refer to the Data Book of the builder or second sources.

SYMBOLS DESCRIPTION

In the manual could appear the following symbols:



Attention: Generic danger



Attention: High voltage

Trade Marks

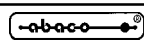
, **GPC®**, **grifo®** : are trade marks of **grifo®**.

Other Product and Company names listed, are trade marks of their respective companies.

GENERAL INDEX

INTRODUCTION	1
CARD VERSION	1
GENERAL INFORMATIONS	2
INTERFACING AND ADDRESSING SECTION	4
CONTROL LOGIC	4
RELAYS OUTPUT SECTION	4
TRANSISTOR OUTPUT SECTION	6
INPUT SECTION	6
CPR 16 TECHNICAL FEATURES	7
CPR 16 GENERAL FEATURES	7
CPR 16 ELECTRIC FEATURES	7
CPR 16 PHYSICAL FEATURES	8
CPT 16 TECHNICAL FEATURES	9
CPT 16 GENERAL FEATURES	9
CPT 16 ELECTRIC FEATURES	9
CPT 16 PHYSICAL FEATURES	10
INSTALLATION	12
CONNECTIONS	12
CN1 - CONNECTOR FOR OPTOCOUPLED INPUTS	12
CN2 - CONNECTOR FOR RELAYS OUTPUTS	14
CN2 - CONNECTOR FOR TRANSISTOR OUTPUTS	16
K1 - CONNECTOR FOR BUS ABACO®	18
VISUAL SIGNALATIONS	20
RESET CIRCUITRY CONFIGURATION	20
JUMPERS	22
2 PINS JUMPERS	22
3 PINS JUMPERS	24
I/O CONNECTIONS	24
POWER SUPPLY	26
CPR 16 POWER SUPPLY	26
CPT 16 POWER SUPPLY	26
HARDWARE DESCRIPTION	28
BOARD MAPPING	28
INTERNAL REGISTERS ADDRESSING	32
INTERNAL REGISTERS ADDRESSING FOR 8 BIT ADDRESSING MODE	32
INTERNAL REGISTERS ADDRESSING FOR 16 BIT ADDRESSING MODE	32

PERIPHERAL DEVICES SOFTWARE DESCRIPTION	33
RELAY OUTPUTS	33
TRANSISTOR OUTPUTS	34
OPTOCOUPLED INPUTS	35
EXTERNAL CARDS	36
BIBLIOGRAPHY	42
APPENDIX A: ALPHABETICAL INDEX	A-1



FIGURES INDEX

FIGURE 1: CPR 16 BLOCK DIAGRAM	3
FIGURE 2: CPT 16 BLOCK DIAGRAM	5
FIGURE 3: CPR 16 COMPONENTS MAP	11
FIGURE 4: CN1 - CONNECTOR FOR OPTOCOUPLED INPUTS	12
FIGURE 5: OPTOCOUPLED INPUTS BLOCK DIAGRAM	13
FIGURE 6: CN2 - RELAYS OUTPUTS CONNECTOR	14
FIGURE 7: RELAYS OUTPUT BLOCK DIAGRAM.....	15
FIGURE 8: CN2 - TRANSISTOR OUTPUTS CONNECTOR	16
FIGURE 9: TRANSISTOR OUTPUTS BLOCK DIAGRAM	17
FIGURE 10: K1 - CONNECTOR FOR BUS ABACO®	18
FIGURE 11: VISUAL SIGNALATIONS TABLE	20
FIGURE 12: CPT 16 COMPONENTS MAP	21
FIGURE 13: JUMPERS SUMMARIZING TABLE	22
FIGURE 14: 2 PINS JUMPERS TABLE	22
FIGURE 15: CPR 16 CONNECTORS, DIP SWITCHES, LEDs AND JUMPERS LOCATION	23
FIGURE 16: 3 PINS JUMPERS TABLE	24
FIGURE 17: CPT 16 CONNECTORS, DIP SWITCHES, LEDs AND JUMPERS LOCATION	25
FIGURE 18: CPR 16 CARD PHOTO	27
FIGURE 19: CPT 16 CARD PHOTO	31
FIGURE 20: INTERNAL REGISTERS ADDRESSING TABLE FOR 8 BIT ADDRESSING MODE	32
FIGURE 21: INTERNAL REGISTERS ADDRESSING TABLE FOR 16 BIT ADDRESSING MODE	32
FIGURE 22: CPR 16 POSSIBLE CONNECTIONS DIAGRAM	37
FIGURE 23: CPT 16 POSSIBLE CONNECTIONS DIAGRAM	39



INTRODUCTION

The use of these devices has turned - IN EXCLUSIVE WAY - to specialized personnel.

The purpose of this handbook is to give the necessary information to the cognizant and sure use of the products. They are the result of a continual and systematic elaboration of data and technical tests saved and validated from the manufacturer, related to the inside modes of certainty and quality of the information.

The reported data are destined- IN EXCLUSIVE WAY- to specialized users, that can interact with the devices in safety conditions for the persons, for the machine and for the environment, impersonating an elementary diagnostic of breakdowns and of malfunction conditions by performing simple functional verify operations , in the height respect of the actual safety and health norms.

The informations for the installation, the assemblage, the dismantlement, the handling, the adjustment, the reparation and the contingent accessories, devices etc. installation are destined - and then executable - always and in exclusive way from specialized warned and educated personnel, or directly from the TECHNICAL AUTHORIZED ASSISTANCE, in the height respect of the manufacturer recommendations and the actual safety and health norms.

The devices can't be used outside a box. The user must always insert the cards in a container that respect the actual safety normative. The protection of this container is not threshold to the only atmospheric agents, but specially to mechanic, electric, magnetic, etc. ones.

To be on good terms with the products, is necessary guarantee legibility and conservation of the manual, also for future references. In case of deterioration or more easily for technical updates, consult the AUTHORIZED TECHNICAL ASSISTANCE directly.

To prevent problems during card utilization, it is a good practice to read carefully all the informations of this manual. After this reading, the user can use the general index and the alphabetical index, respectly at the begining and at the end of the manual, to find information in a faster and more easy way.

CARD VERSION

The present manual is reported to the boards **CPR 16** and **CPT 16** version **240499** and later.

The validity of the bring informations is subordinate to the number of the card release. The user must always verify the correct correspondence among the two denotations. Version number is printed on the boards in several positions both in serigraph and in printed circuit (for example on **CPR 16** near the board's name on the component side and on **CPT 16** amongst the optocouplers on the component side).

GENERAL INFORMATION

The **CPR 16** (Coupled PNP Relays 16 outputs and 16 inputs) and **CPT 16** (Coupled PNP Transistors 16 outputs and 16 inputs) are powerful digital I/O module that provide each one on one only board the features normally available on two boards. This extreme compactness, distinctive feature of **grifo**® boards, allows to optimize room and cost of the final application. The boards use only as low as two bytes of addressing space, distinguishing the two sections for read or write operations. No software initialization is needed to use the board. When a Power on or Reset occur **CPR 16** and **CPT 16** disable the 16 outputs through a specific circuitry (if it has not been excluded by moving a jumper) warranting so the absence of any kind of inconsistency of the initial status.

The output section of **CPR 16** is made by normally open relays with disturb suppression, while the output section of **CPT 16** is made by open collector PNP Darlington transistors with back EMF protection diode. Both the cards are provided with signalation LEDs to have a visual indication of the outputs' status. The sixteen input signals, galvanically isolated and PNP type, are provided with a π filter and a LED to indicate the status of each single input. This allows great disturb immunity and an immediate visual control of the inputs' status.

The connection with the external world is performed through two comfortable standard I/O connectors located on the front of the board. One of the connectors is dedicated to inputs, the other one is dedicated to outputs. This separation increases the safety in the working of the board.

To simplify the connection of the several signals to the external world, the BLOCK modules of FBC serie are available. These modules have been designed to unravel the signals coming from the two flat cables to comfortable quick release screw terminal connectors. The best choices are **FBC 34**, **FBC 20**, **FBC 120**, **FBC L34** e **FBC L20**.

The latter two **FBC**, **L34** and **L20**, allow to visualize the signals status through LEDs, making easier the task to control the correct cables connections even when the board is already in a Rack. A remarkable feature of **CPR 16** and **CPT 16** is the possibility to have a BUS data path of 8 or 16 bits and a BUS addresses path of 8 or 16 bits. Selection of operational mode (Byte or Word) and addressing range is performed through comfortable jumpers and visualized through LEDs.

- Single Europe format size 100x160 mm with BUS **ABACO**® industrial interface
- **16 digitali** output signals: with **Relays** featuring **1A, 24V**, and MOV disturb suppressor for the 24 Vac model (**CPR 16**)
with open collector **Darlington PNP** transistor, optocoupled, featuring **4A, 45Vdc**, without heat sink and back EMF protection diode (**CPT 16**)
- **16** LEDs to visualize the outputs' status, **16** LEDs to visualize the inputs' status
- Anti-activation during the power on circuitry
- **16** digital **optocoupled PNP** input signals with **π filter** on each input
- I/O mapping selection through two on board **Dip Switches**
- Addressing space needed as low as 2 bytes contiguous
- BUS data and addresses path can be **8** or **16** bits, selectable through jumpers,
- BUS configuration visualized through **3 LEDs**
- Possibility to connect or disconnect BUS /RESET signal
- **20 pins** standard input connector and **34 pins** standard output connector
- Direct connection to interfaces for the external world **FBC 34**, **FBC L34**, etc.
- Power supply: **CPR 16** Multi supply version: **+5 Vdc** and **+12 Vdc**
CPR 16.05 Single supply version: **+5 Vdc**
CPT 16 needs a unique power supply: **+5 Vdc**
- Power supply for optocoupled input **12÷24Vdc**

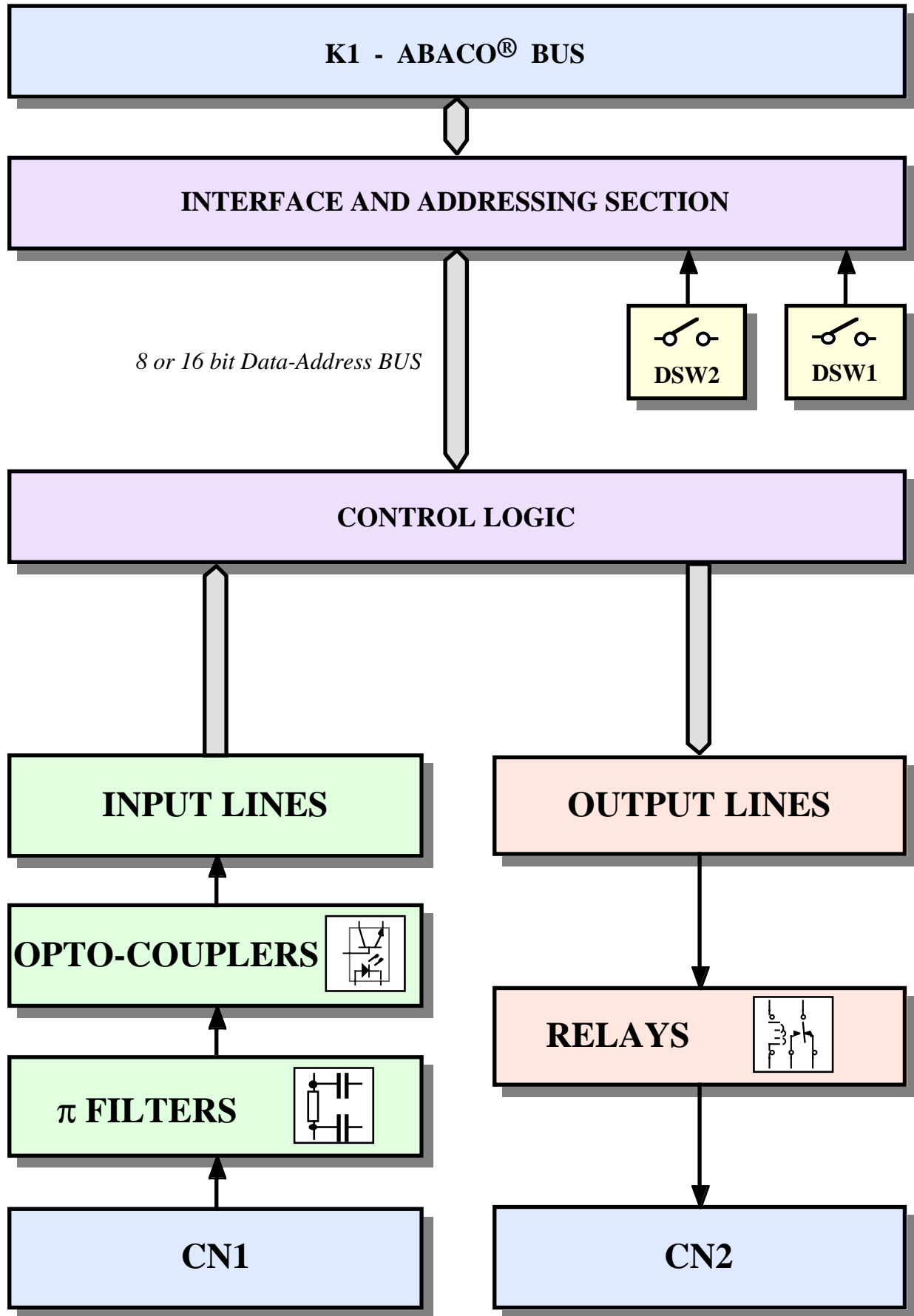

FIGURE 1: CPR 16 BLOCK DIAGRAM

Here follows a description of **CPR 16** and **CPT 16** boards' functional blocks, with an indication of the operations performed by each block. To easily locate these blocks and verify their connections please refer to figures 1 and 2.

INTERFACING AND ADDRESSING SECTION

This section manages the data exchange between control logic and command board through BUS **ABACO**®. In particular, all written or read data transit across this section that, in addition, provides the board I/O management, by setting the dip switch **DSW1** and **DSW2**. Please remark that this section can be configured to make **CPR 16** and **CPT 16** addressable in a physical space of 256 or 64 Kbytes.

Industrial BUS **ABACO**® supports both 8 bits and 16 bits addressing mode.

For further information please refer to the chapter dedicated to board's software description.

CONTROL LOGIC

This section generates all the chip select signals needed to access the several peripherals on **CPR 16** and **CPT 16** boards. Using this section the programmer can interact to the board's several sections, verifying their status, reading digital input configurations, setting output signals, etc.

All this can be done through a simple software management based on BUS **ABACO**®, to which the control logic connects through the interfacing and addressing section. For further information please refer to the chapter dedicated to board's software description.

RELAYS OUTPUT SECTION

This section features 16 Output signals driven by one or more latches. These components are managed through specific read/write registers, according to the informations contained in the chapters dedicated to board's hardware and software description. Any Output signal, visualized through its own LED, controls a 1A Relay, normally open, provided with a MOV 24 Vac noise suppressor. The power supply for the relays can be +12 Vdc, coming from BUS **ABACO**® (standard version of **CPR 16**), or the same voltage of +5 Vdc that supplies the on board logic circuits (version **CPR 16.05**). This latter solution allows to have a unique stabilized voltage to supply the whole system, with a greater total current consumption.

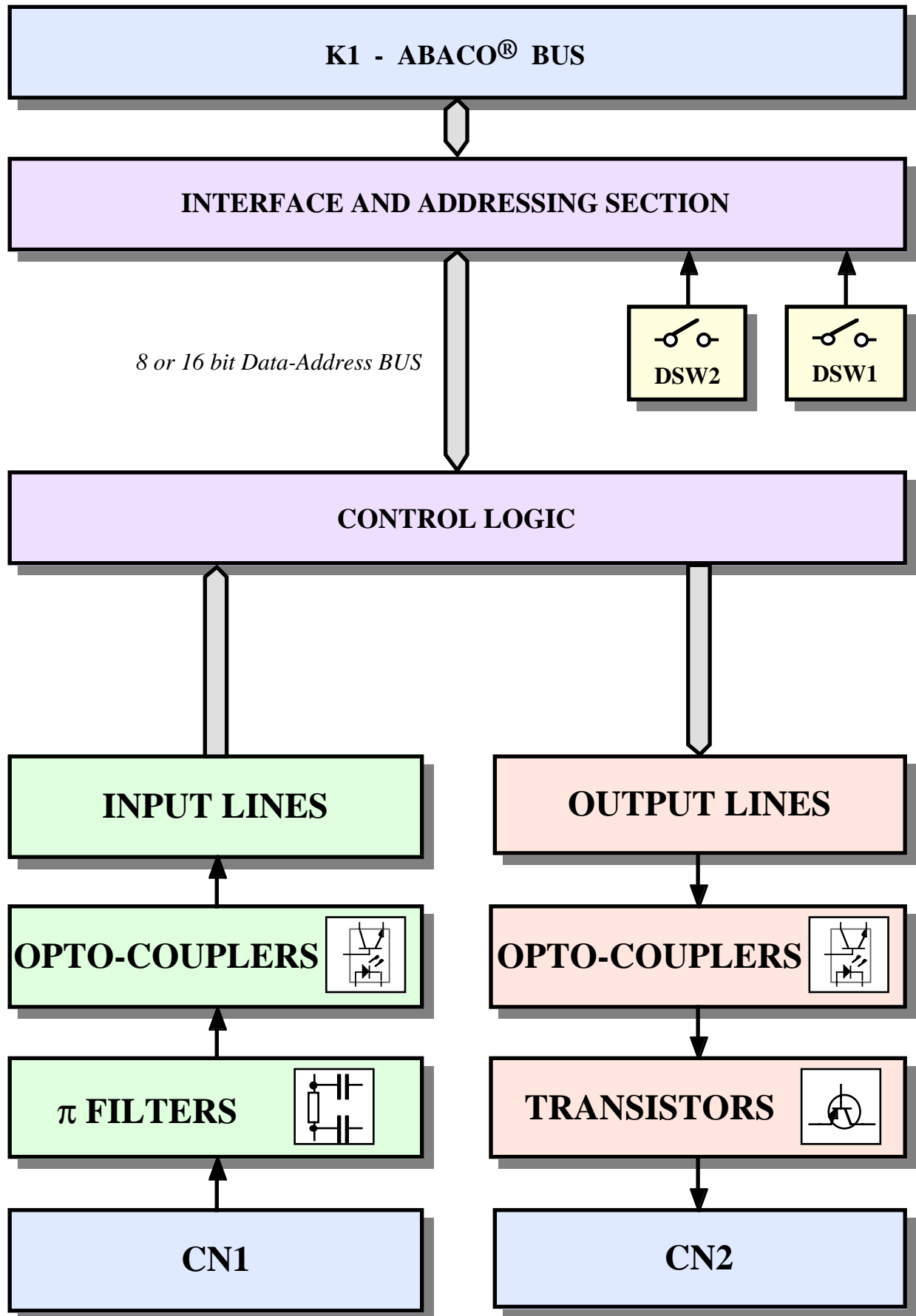

FIGURE 2: CPT 16 BLOCK DIAGRAM

TRANSISTOR OUTPUT SECTION

This section features 16 Output signals driven by one or more latches. These components are managed through specific write registers, according to the informations contained in the chapters dedicated to board's hardware and software description. Any Output signal, optocoupled and visualized through its own LED, controls a 4A (not continuative), 45 Vdc open collector Darlington PNP transistor provided with back EMF protection diode. The power supply is +5 Vdc, which supplies the on board logic circuits. This solution allows to have an unique stabilized voltage to supply the whole system.

INPUT SECTION

This section features 16 Input signals, acquired through input buffers. These components are managed by specific read registers, according to the informations contained in the chapters dedicated to board's hardware and software description. Any Input signal is galvanivally isolated, PNP type and visualized through its own LED. Optocouplers of this section are supplied through a voltage in the range from +12 Vdc to +24 Vdc that must be provided by means of a specific connector. All the input signals are protected by a π filter, that warrants a high immunity against the disturbs from the external world.

CPR 16 TECHNICAL FEATURES

CPR 16 GENERAL FEATURES

On board resources:	16 optocoupled PNP Input 16 Output 1A relays N.O. 2 Dip switches 8 pins for I/O address setting
BUS type:	Industrial ABACO ® 8 or 16 bits data and addresses.
N. addressable bytes:	Selectable between 256 bytes and 64 Kbytes
N. bytes / word occupied:	2 / 1

CPR 16 ELECTRIC FEATURES

Standard version CPR 16

Power supply:	+5 Vdc (logic circuits) +12 Vdc (relays) +12÷24 Vdc (Vopto: optocoupled inputs)
Current consumption:	190 mA (+5 Vdc) 300 mA (+12 Vdc) 192 mA (with Vopto = +24 Vdc)

Single supply version CPR 16.05

Power supply:	+5 Vdc (logic circuits and relays) +12÷24 Vdc (Vopto: optocoupled inputs)
Current consumption:	800 mA (+5 Vdc) 192 mA (with Vopto = +24 Vdc)
Max current on the relay contact:	1 A
Max voltage on the relay contact:	24 Vac / 24 Vdc Should the User need to connect higher voltages please contact grifo ®
Relays protection:	24 Vac MOV transient suppressor
Filter on NPN inputs:	π filter
Minimum current for PNP inputs:	1,6 mA

CPR 16 PHYSICAL FEATURES

Size:	Standard EUROPE format 100x160 mm
Weight:	210 g
Connectors:	K1: DIN 41612 64 pins M 90° A+C type C CN1: Low profile 20 pins M 90° strain relief clamp CN2: Low profile 34 pins M 90°
Temperature range:	from 0 to 70 centigrad degrees
Relative humidity:	20% up to 90% (without condense)

CPT 16 TECHNICAL FEATURES

CPT 16 GENERAL FEATURES

On board resources:	16 optocoupled NPN Input 16 Output open collector Darlington PNP transistor 2 Dip switches with 8 pins to set the I/O addressing
BUS type:	Industrial ABACO ® 8 or 16 bits data and addresses.
N. addressable bytes:	256 bytes or 64 Kbytes
N. bytes / word occupied:	2 / 1

CPT 16 ELECTRIC FEATURES

Power supply:	+5 Vdc (logic circuits and transistors) +12÷24 Vdc (Vopto: optocoupled inputs)
Current consumption:	420 mA (+5 Vdc) 192 mA (con Vopto = +24 Vdc)
Max current for transistor:	4 A non continuative (*) 600 mA continuative, supplying a resistive load at +24 Vdc (*)
Max voltage on transistors:	45 Vdc (*)
Max power each transistor:	1.25 W (*)
Transistor protection:	Back EMF protection diode
Filter on PNP inputs:	π filter
Minimum current on PNP inputs:	1.6 mA

(*) Values referred to a working temperature of 20 °C

CPT 16 PHYSICAL FEATURES

Size:	Standard EUROPE format 100x160 mm
Weight:	170 g
Connectors:	K1: DIN 41612 64 pins M 90° A+C type C CN1: Low profile 20 pins M 90° strain relief clamp CN2: Low profile 34 pins M 90°
Temperature range:	from 0 to 70 centigrad degrees
Relative humidity:	20% up to 90% (without condense)

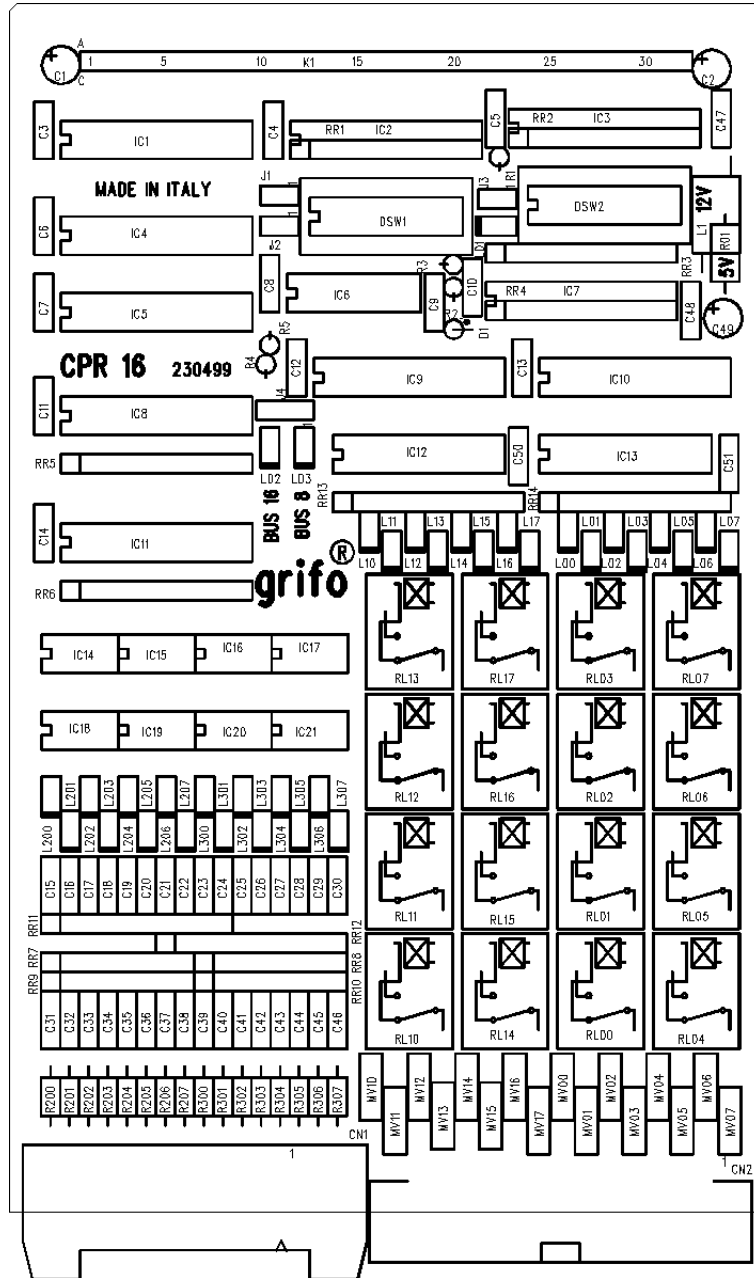

FIGURE 3: CPR 16 COMPONENTS MAP

INSTALLATION

In this chapter there are the information for a right installation and correct use of **CPR/T 16** cards. The User can find the location and functions of each connectors, jumpers, LEDs and some explanatory diagrams.

CONNECTIONS

The **CPR/T 16** cards have several connectors that can be linkeded to other devices or directly to the field, according to system requirements. In this paragraph there are connectors pin outs, a short signals description (including the signals direction) and connectors location (please see figures 15 and 17), plus some figures that describe how the interface signals are connected on the cards.

CN1 - CONNECTOR FOR OPTOCOUPLED INPUTS

The connector for optocoupled PNP inputs, called CN1, is a low profile, 2.54 mm pitch, 90 degreeses, 20 pins connector.

The connector features the 16 inputs of **CPR/T 16** cards and the lines to supply the optocouplers.

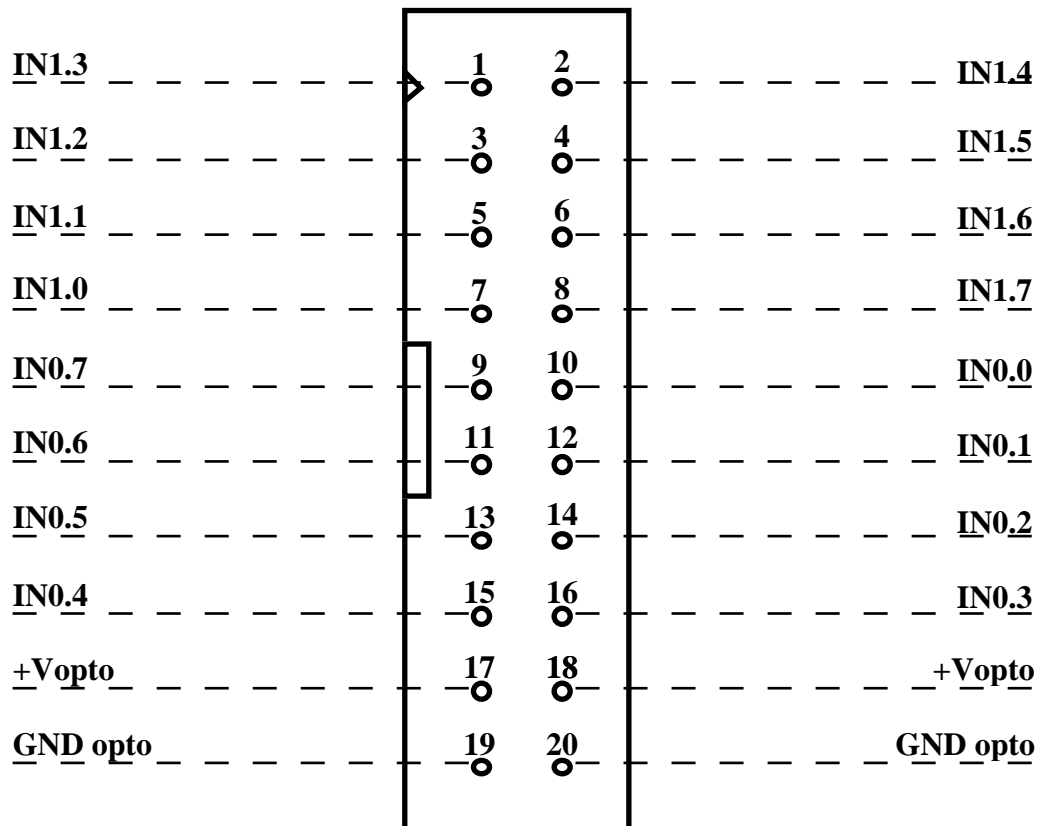

FIGURE 4: CN1 - CONNECTOR FOR OPTOCOUPLED INPUTS

Signals description:

- IN0.n** = I - n-th optocoupled PNP input n of section IN0.
- IN1.n** = I - n-th optocoupled PNP input n of section IN1.
- +V opto** = I - Optocouplers power supply in the range +12÷24 Vdc for sections IN0 and IN1.
- GND opto** = - Common terminal of optocouplers power supply for sections IN0 and IN1.

The NPN input signals available on **CPR/T 16** are optocoupled and provided with π filter to warrant a high degree of protection against noise and disturbs from the external world. Each signal is provided with a LED for visual feed back (the LED will light whenever the input will have the potential of GND opto signal); this means that the inputs are going to support normally open contacts. These contacts are suitable to be connected to PNP drivers.

The interface circuitry for the 16 lines of the input section is shown in the following diagram.

The supply voltage of the optocouplers must be **+12÷24 Vdc** and must be provided through the specific pins of CN1.

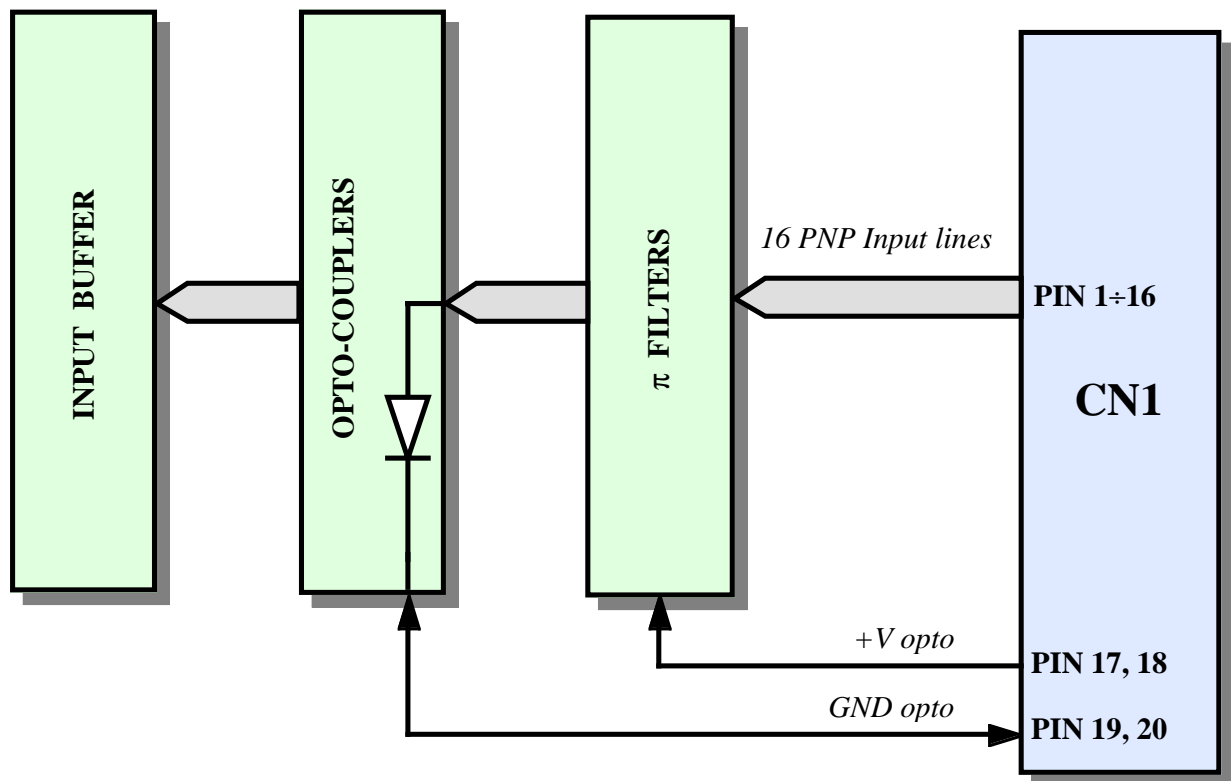

FIGURE 5: OPTOCOUPLED INPUTS BLOCK DIAGRAM

CN2 - CONNECTOR FOR RELAYS OUTPUTS

The connector for relays outputs, called CN2, is a low profile, 2.54 mm pitch, 90 degrees, 34 pins connector. Normally open contacts of each relay output and two common terminals related to two output groups OUT0 and OUT1 are present; please remark that the maximum current for each relay is 1 A.

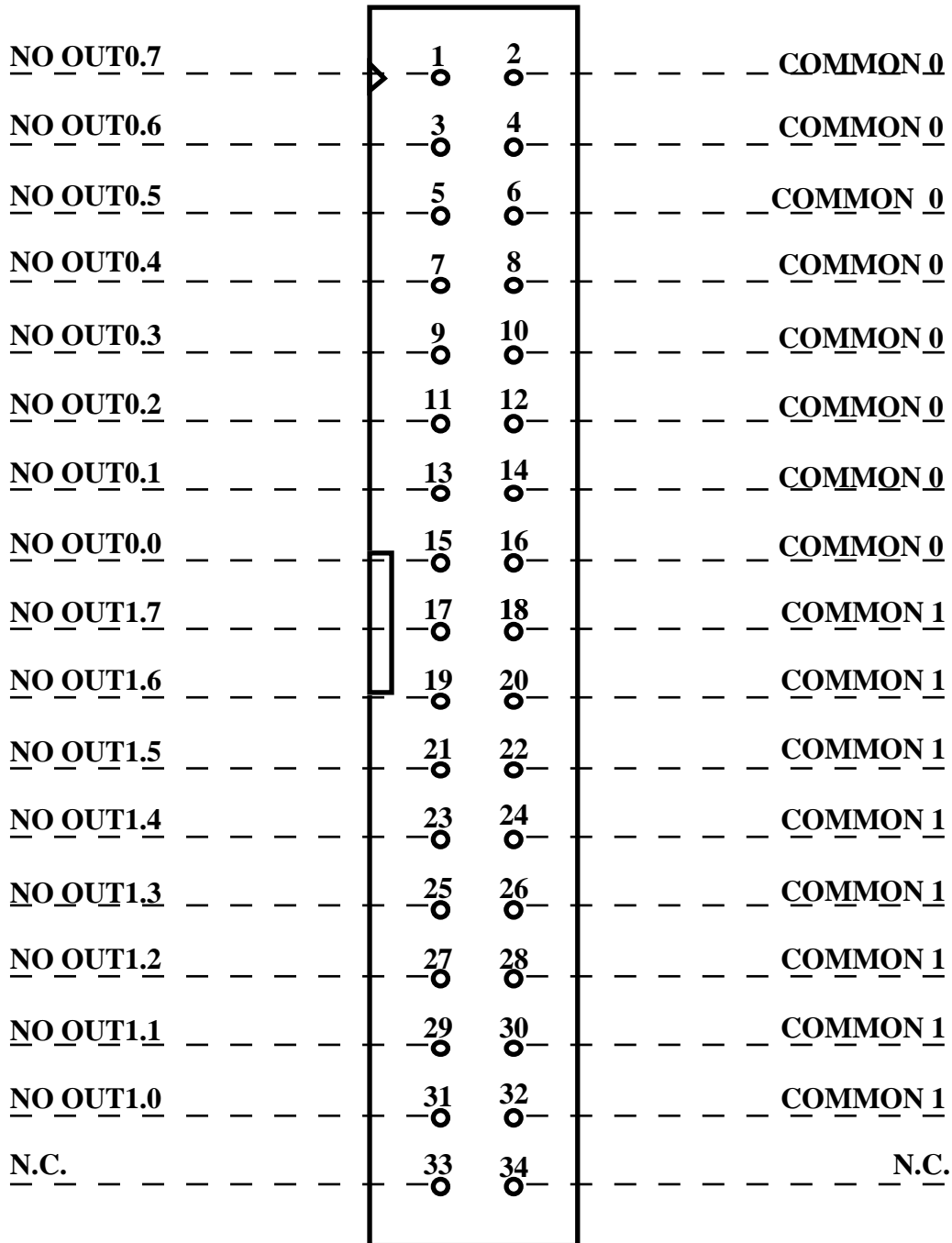

FIGURE 6: CN2 - RELAYS OUTPUTS CONNECTOR

Signals description:

NO OUT0.n	= O	- Contact of n-th normally open output in section OUT0.
COMMON 0	=	- Common contact of the 8 relays of section OUT0.
NO OUT1.n	= O	- Contact of n-th normally open output in section OUT1.
COMMON 1	=	- Common contact of the 8 relays of section OUT1.
N.C.	=	- Not conneced.

The relays output signals available on **CPR 16** are provided with a LED for visual feed back (the LED will light whenever the relay contact is closed); the relays are normally open, provided with a **MOV** transients suppressor, they can bear a maximum current of **1 A** with a maximum tension of **24 Vdc** or **24 Vac**.

The interface circuitry for this relays output section is shown in the following diagram.

NOTE

Should the User connect to the relays a voltage higher to the one declared in this manual, please contact **grifo®** directly; in fact this implies a different hardware configuration that must be performed by **grifo®** technicians.

The connector features the normally open contacts of each output and two common terminals related to output groups OUT0 and OUT1; when making the connections please remark that the maximum current for each relay is 1 A.

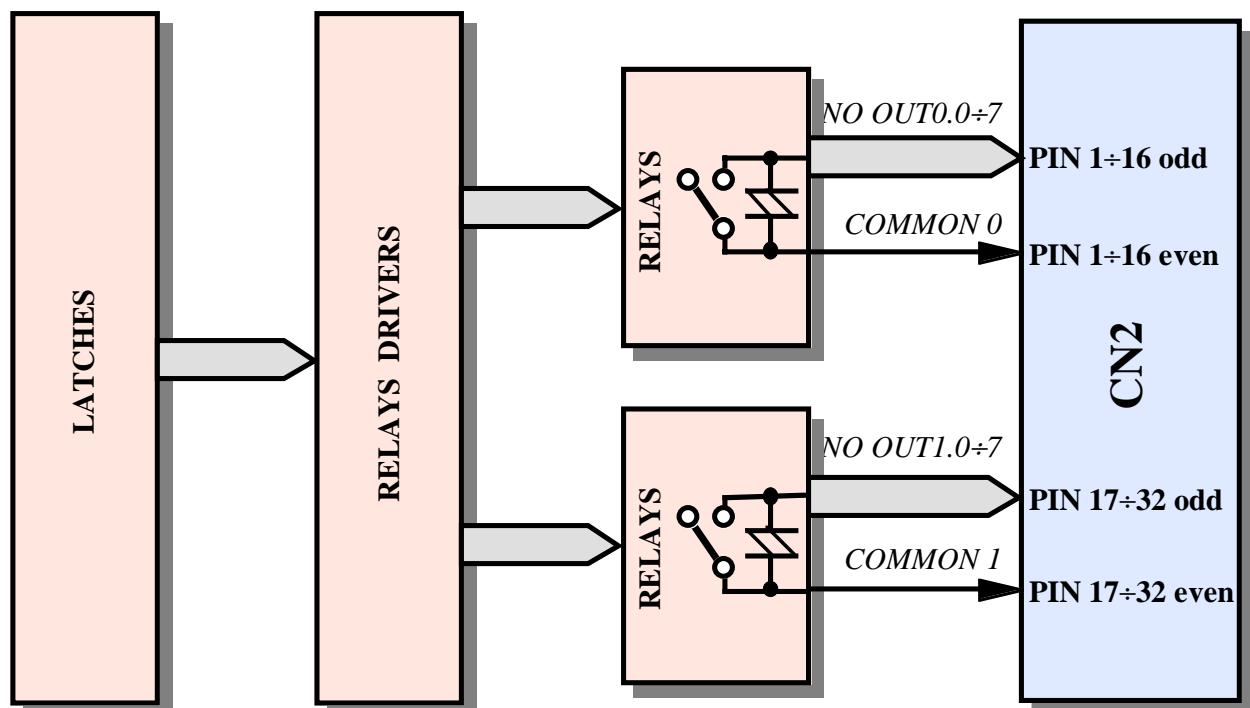

FIGURE 7: RELAYS OUTPUT BLOCK DIAGRAM

CN2 - CONNECTOR FOR TRANSISTOR OUTPUTS

The connector for Darlington PNP transistor outputs, called CN2, is a low profile, 2.54 mm pitch, 90 degrees, 34 pins connector. Open collector contacts of each output transistor and two common terminals related to two output groups OUT0 and OUT1 are present; in addition the contacts to connect to the negative terminals of loads to discharge eventual inductive voltages are present; please remark that the maximum current for each transistor is 4 A non continuative, maximum voltage is +45 Vdc.

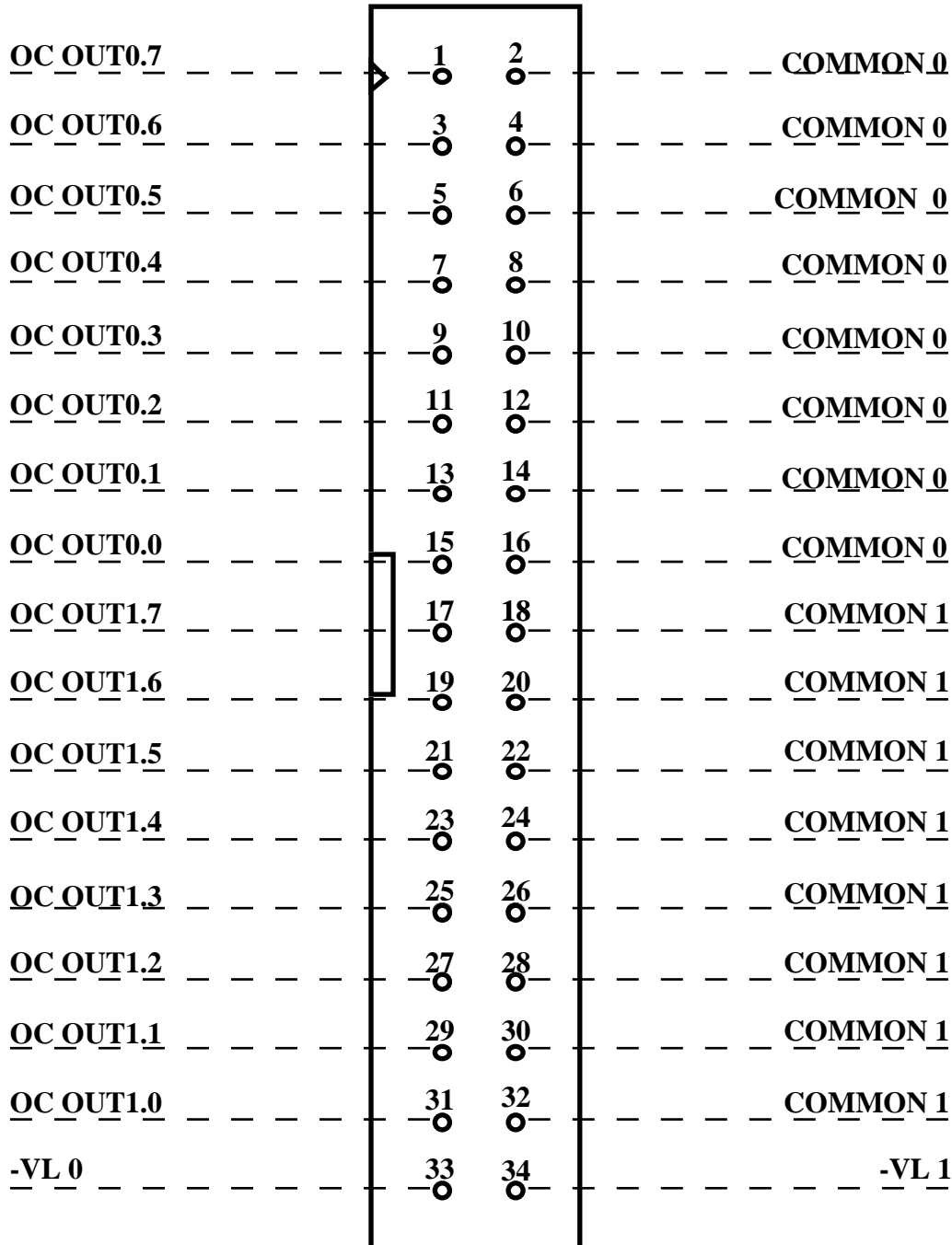

FIGURE 8: CN2 - TRANSISTOR OUTPUTS CONNECTOR

Signals description:

- OC OUT0.n** = O - Contact of n-th open collector output in section OUT0.
- COMMON 0** = I - Common contact of the 8 transistors of section OUT0.
- VL 0** = - Contact for the negative terminals of the loads' power supply for section OUT0. This is also the common point for the back EMF protection diodes.
- OC OUT1.n** = O - Contact of n-th open collector output in section OUT1.
- COMMON 1** = I - Common contact of the 8 transistor of section OUT1.
- VL 1** = - Contact for the negative terminals of the loads' power supply for section OUT1. This is also the common point for the back EMF protection diodes.

The transistor output signals available on **CPT 16** are provided with a LED for visual feed back (the LED will light whenever the transistor is conducting); in addition they are optocoupled, to warrant galvanic separation between internal electronics and external world.

The final stage of the outputs is made by a Darlington **PNP** open collector transistor, capable to bear a maximum current of **4 A non continuative** or a tension that can be as high as **+45 Vdc**.

Please remark that this component, being without heat sink, can drive in continuative way a resistive load absorbing a maximum current of **600 mA** at a tension of **+24 Vdc**, at a working temperature of 20 centigrad degrees.

The interface circuitry for this 16 transistors output section is shown in the following diagram.

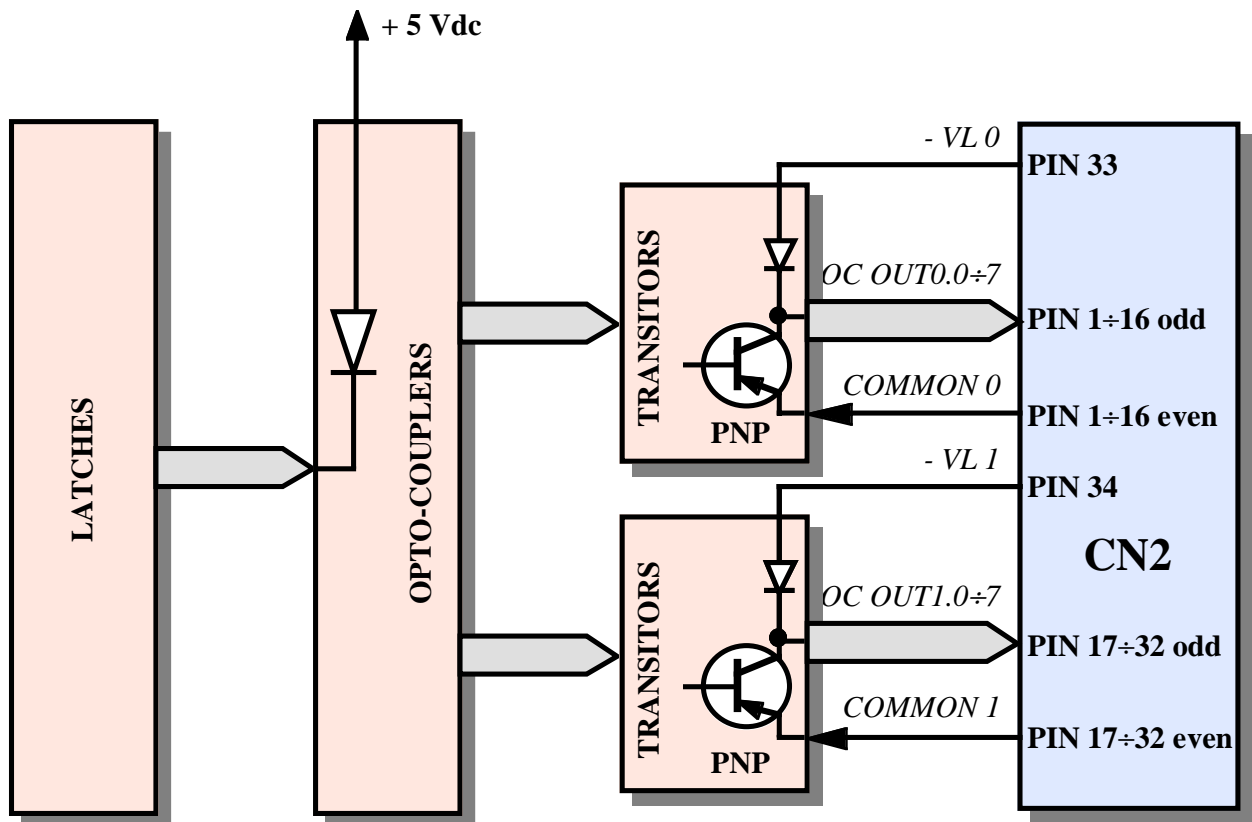

FIGURE 9: TRANSISTOR OUTPUTS BLOCK DIAGRAM

K1 - CONNECTOR FOR BUS ABACO®

The connector for **ABACO® industrial BUS**, called K1 on the board, is a DIN 41612, male, a 90 degree, type C, A+C.

Here follows the pin-out of the connector installed on **CPR/T 16**, in addition there is the standard 8 bits and 16 bits **BUS ABACO®** pin-out.

Please remark that all the signals here described are TTL, except for the power supplies.

A 16 bit BUS	A 8 bit BUS	A CPR/T 16	PIN	C CPR/T 16	C 8 bit BUS	C 16 bit BUS
GND	GND	GND	1	GND	GND	GND
+5 Vdc	+5 Vdc	+5 Vdc	2	+5 Vdc	+5 Vdc	+5 Vdc
D0	D0	D0	3	D8		D8
D1	D1	D1	4	D9		D9
D2	D2	D2	5	D10		D10
D3	D3	D3	6	N.C.	/INT	/INT
D4	D4	D4	7	N.C.	/NMI	/NMI
D5	D5	D5	8	D11	/HALT	D11
D6	D6	D6	9	N.C.	/MREQ	/MREQ
D7	D7	D7	10	/IORQ	/IORQ	/IORQ
A0	A0	A0	11	/RD	/RD	/RD LDS
A1	A1	A1	12	/WR	/WR	/WR LDS
A2	A2	A2	13	D12	/BUSAK	D12
A3	A3	A3	14	N.C.	/WAIT	/WAIT
A4	A4	A4	15	D13	/BUSRQ	D13
A5	A5	A5	16	/RESET	/RESET	/RESET
A6	A6	A6	17	/M1	/M1	/IACK
A7	A7	A7	18	D14	/RFSH	D14
A8	A8	A8	19	N.C.	/MEMDIS	/MEMDIS
A9	A9	A9	20	N.C.	VDUSEL	A22
A10	A10	A10	21	D15	/IEI	D15
A11	A11	A11	22	N.C.		
A12	A12	A12	23	N.C.	CLK	CLK
A13	A13	A13	24	/RDUDS		/RDUDS
A14	A14	A14	25	/WRUDS		/WRUDS
A15	A15	A15	26	N.C.		A21
A16		N.C.	27	N.C.		A20
A17		N.C.	28	N.C.		A19
A18		N.C.	29	N.C.	/R.T.	/R.T.
+12 Vdc	+12 Vdc	+12 Vdc (CPR 16)	30	N.C.	-12 Vdc	-12 Vdc
+5 Vdc	+5 Vdc	+5 Vdc	31	+5 Vdc	+5 Vdc	+5 Vdc
GND	GND	GND	32	GND	GND	GND

FIGURE 10: K1 - CONNECTOR FOR BUS ABACO®

Signals description:

8 bits CPU

A0-A15	=	O	- Address BUS
D0-D7	=	I/O	- Data BUS
INT	=	I	- Interrupt request
NMI	=	I	- Non Maskable Interrupt
HALT	=	O	- Halt state
MREQ	=	O	- Memory Request
IORQ	=	O	- Input Output Request
RD	=	O	- Read cycle status
WR	=	O	- Write cycle status
BUSAK	=	O	- BUS Acknowledge
WAIT	=	I	- Wait
BUSRQ	=	I	- BUS Request
RESET	=	O	- Reset
M1	=	O	- Machine cycle one
RFSH	=	O	- Refresh for dynamic RAM
MEMDIS	=	I	- Memory Display
VDUSEL	=	O	- VDU Selection
IEI	=	I	- Interrupt Enable Input
CLK	=	O	- System clock
R.B.	=	I	- Reset button
+5 Vdc	=	I	- Power supply at +5 Vdc
+12 Vdc	=	I	- Power supply at +12 Vdc
-12 Vdc	=	I	- Power supply at -12 Vdc
GND	=		- Ground signal

16 bits CPU

A16-A22	=	O	- Address BUS
D8-D15	=	I/O	- Data BUS
RD UDS	=	O	- Read Upper Data Strobe
WR UDS	=	O	- Write Upper Data Strobe
IACK	=	O	- Interrupt Acknowledge
RD LDS	=	O	- Read Lower Data Strobe
WR LDS	=	O	- Write Lower Data Strobe

N.B.

Directionality indications as above stated are referred to a master (**CPU** or **GPC**®) board and have been kept untouched to avoid ambiguity in case of multi-boards systems.

VISUAL SIGNALATIONS

CPR 16 and **CPT 16** cards are provided with signalation LEDs to show several status informations, as described in the following table:

LED	COLOUR	PURPOSE
LD1	Green	Indicates the 64 Kbytes extended addressing mode when it is on.
LD2	Red	When it is on, indicates that 16 bit data BUS is used.
LD3	Yellow	When it is on, indicates that 8 bit data BUS is used.
L00÷L07	Red	Visualize the status of the eight outputs of section OUT0, respectively OUT0.0÷OUT0.7. A LED on indicates an active output (relay contact closed or o. c. transistor conducting).
L10÷L17	Red	Visualize the status of the eight outputs of section OUT1, respectively OUT1.0÷OUT1.7. A LED on indicates an active output (relay contact closed or o. c. transistor conducting).
L200÷L207	Green	Visualize the status of the eight otocoupled input signals IN0, respectively IN0.0÷IN0.7. A LED on indicates an input contact closed.
L300÷L307	Yellow	Visualize the status of the eight otocoupled input signals IN1, respectively IN1.0÷IN1.7. A LED on indicates an input contact closed.

FIGURE 11: VISUAL SIGNALATIONS TABLE

The main purpose of LEDs is to show a visual indication about the card's status, making so easier debug and verify operations.

To easily locate these visual signalations please refer to the figures 15 and 17.

RESET CIRCUITRY CONFIGURATION

Through jumper **J2**, as described in the next paragraph, the User may select whether to connect or not the /RESET signal coming from BUS **ABACO**[®] to the specific circuitry on the board **CPR 16** and **CPT 16**; if the jumper is **connected**, when the /RESET is active the board's outputs are **disabled**. Viceversa if the jumper is **not connected**, /RESET signal **doesn't affect** the status of the outputs, that are disabled whenever a Power-On occurs. This feature is essential when, for example, the outputs must not change status for a control board's reset due to, for example, an intervent of its on board Watch Dog circuitry.

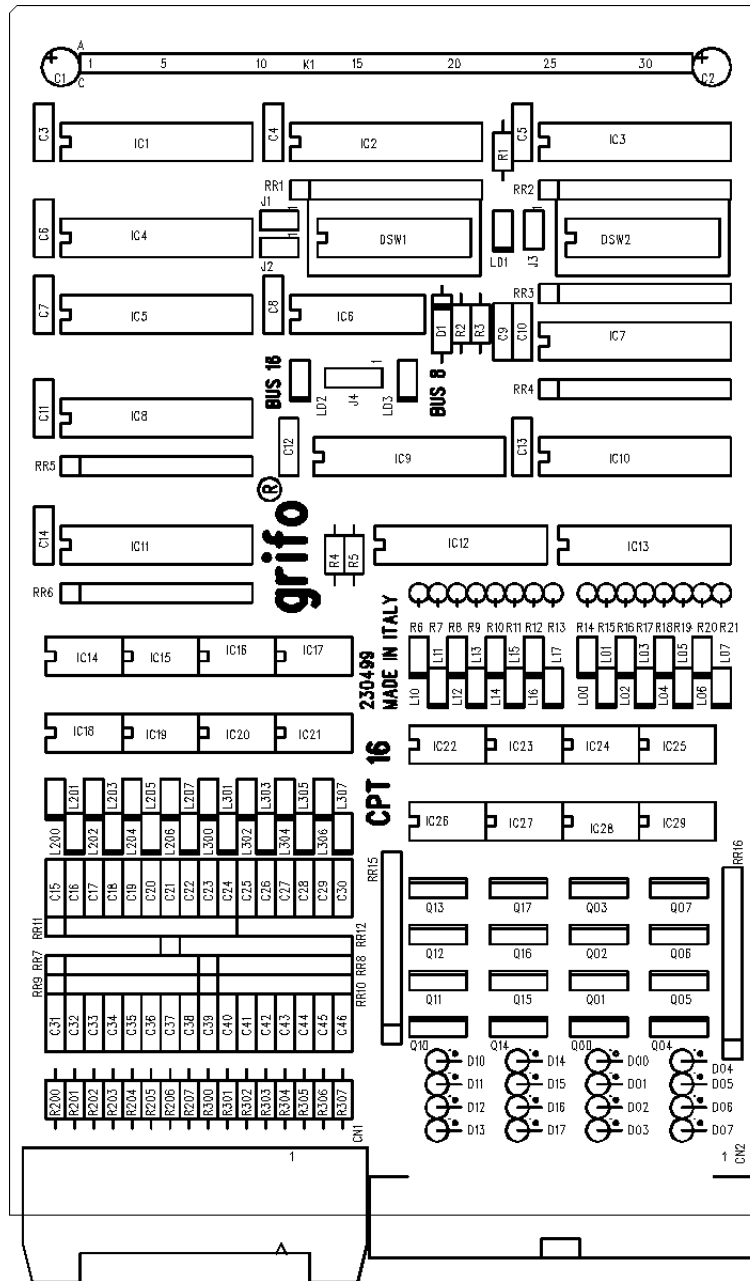

FIGURE 12: CPT 16 COMPONENTS MAP

JUMPERS

On **CPR 16** and **CPT 16** boards there are 4 jumpers for card configuration. Below there is the jumpers list, location and function.

JUMPER	N. PINS	PURPOSE
J1	2	It selects the connection of signal /M1, coming from BUS ABACO [®] , to the specific circuitry installed on the board.
J2	2	It selects the connection of signal /RESET, coming from BUS ABACO [®] , to the specific circuitry installed on the board.
J3	2	It selects between 256 bytes normal addressing mode or 64 Kbytes extended addressing mode.
J4	3	Selects BUS addresses path between 8 or 16 bits.

FIGURE 13: JUMPERS SUMMARIZING TABLE

These tables describe all the right connections of the three jumpers with their relative functions. For recognizing jumpers location, please refer to the figure 3 and 12. To easily locate the jumpers on the board please refer to figures 15 and 17.

The "*" used in the following tables, denotes the default connection, or on the other hand the connection set up at the end of testing phase, that is the configuration the user receives.

2 PINS JUMPERS

JUMPER	CONNECTION	PURPOSE	DEF.
J1	not connected	Parallel interface does not manage signal /M1 coming from BUS ABACO [®] .	
	connected	Parallel interface manages signal /M1 coming from BUS ABACO [®] .	*
J2	not connected	It does not connect the signal /RESET, coming from ABACO [®] BUS, to the specific circuitry installed on the board.	
	connected	It connects the signal /RESET, coming from ABACO [®] BUS, to the specific circuitry installed on the board.	*
J3	not connected	Selects the board's 256 bytes normal addressing mode.	*
	connected	Selects the board's 64 Kbytes extended addressing mode.	

FIGURE 14: 2 PINS JUMPERS TABLE

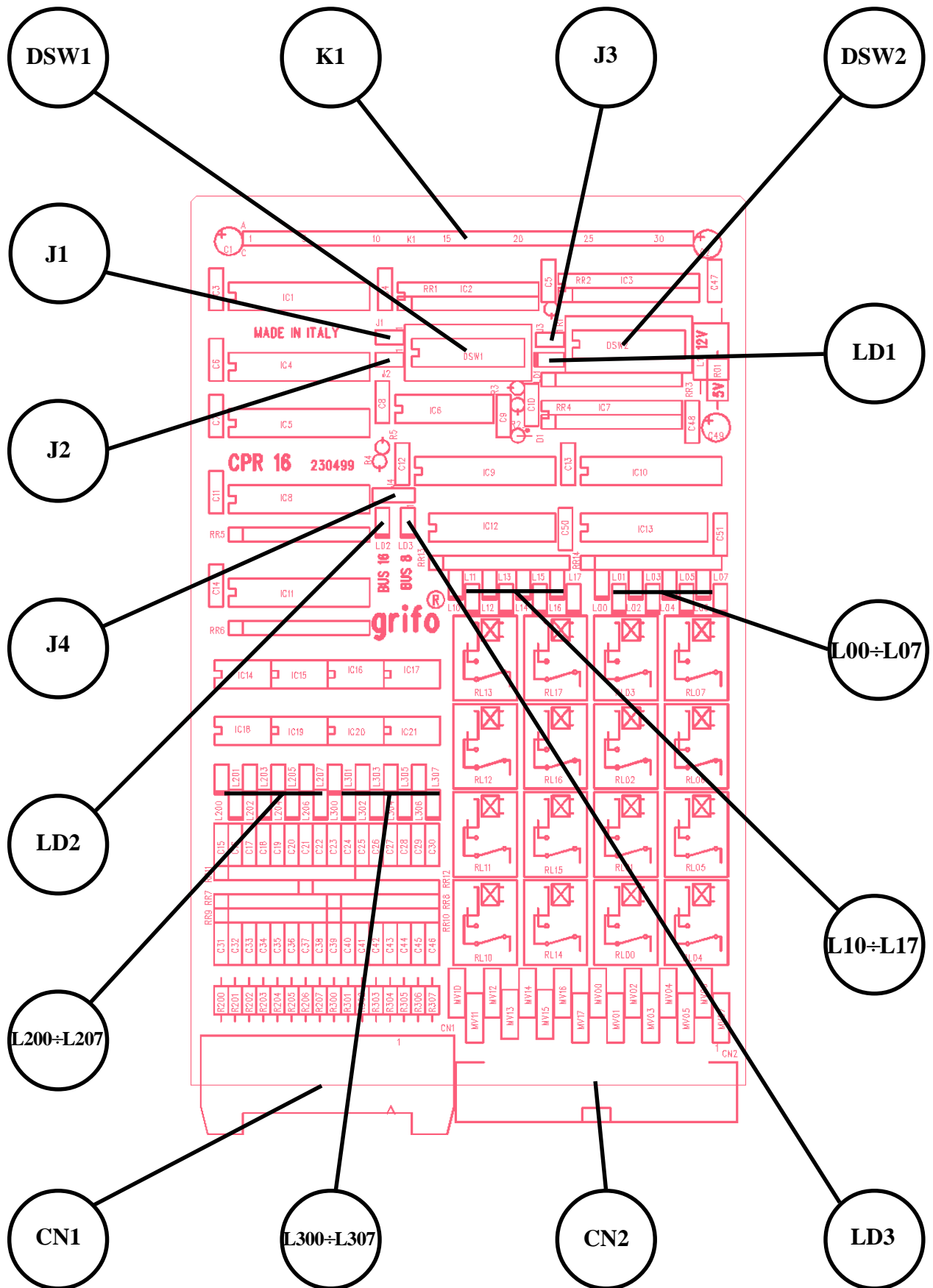

FIGURE 15: CPR 16 CONNECTORS, DIP SWITCHES, LEDs AND JUMPERS LOCATION

3 PINS JUMPERS

JUMPER	CONNECTION	PURPOSE	DEF.
J4	position 1-2	Configures the board to be managed through an 8 bits wide BUS data path.	*
	position 2-3	Configures the board to be managed through a 16 bits wide BUS data path.	

FIGURE 16: 3 PINS JUMPERS TABLE

I/O CONNECTIONS

To prevent possible connecting problems between **CPR 16** and **CPT 16** board and the external systems, the User has to read carefully the information of the previous paragraphs and he must follow these instructions:

- To connect to the optocoupled input signals, only the contacts to acquire must be connected from the external system(s). These contacts (relays, switches, etc.) must connect or not connect the input signal INx.y to +V opto. About the correspondance between logic signals and contact status, an open contact generates a logic **1**, a closed contact generates a logic **0**, following the PNP standard
- The Darlington PNP transistors output signals (on CPT 16) must be connected directly to the load to drive (power relays, etc.). The board provides the open collector outputs called OC OUTx.y, capable to bear a maximum current of **4 A non continuative** with a tension that can be **+45 Vdc**. Being without heat sink, they can drive in continuative way a resistive load absorbing a maximum current of **600 mA** at a tension of **+24 Vdc**, at a working temperature of 20 centigrad degrees. To allow the User to drive several loads having different power supplies, each output section is provided with two differnt COMMON terminals connected to two groups of eight relays..
- The relays output signals (on **CPR 16**) must be connected directly to the load to drive (power relays, etc.). The board provides the normally open contacts called NO OUTx.y, capable to bear a maximum current of **1 A** with a tension that can be **24 Vdc** or **24 Vac**. To allow the User to drive several loads having different power supplies, each output section is provided with two differnt COMMON terminals connected to two groups of eight relays.

NOTE: Should the User connect to the relays a voltage higher to the one declared in this manual, please contact **grifo**[®] directly; in fact this implies a different hardware configuration that must be performed by **grifo**[®] technicians.

- The TTL signals can be connected directly only to a device featuring the same type of interface. About the correspondance between logic signals and TTL output status, remember that a logic **0** generates a TTL 0 Vdc, while a logic **1** generates a TTL +5 Vdc.

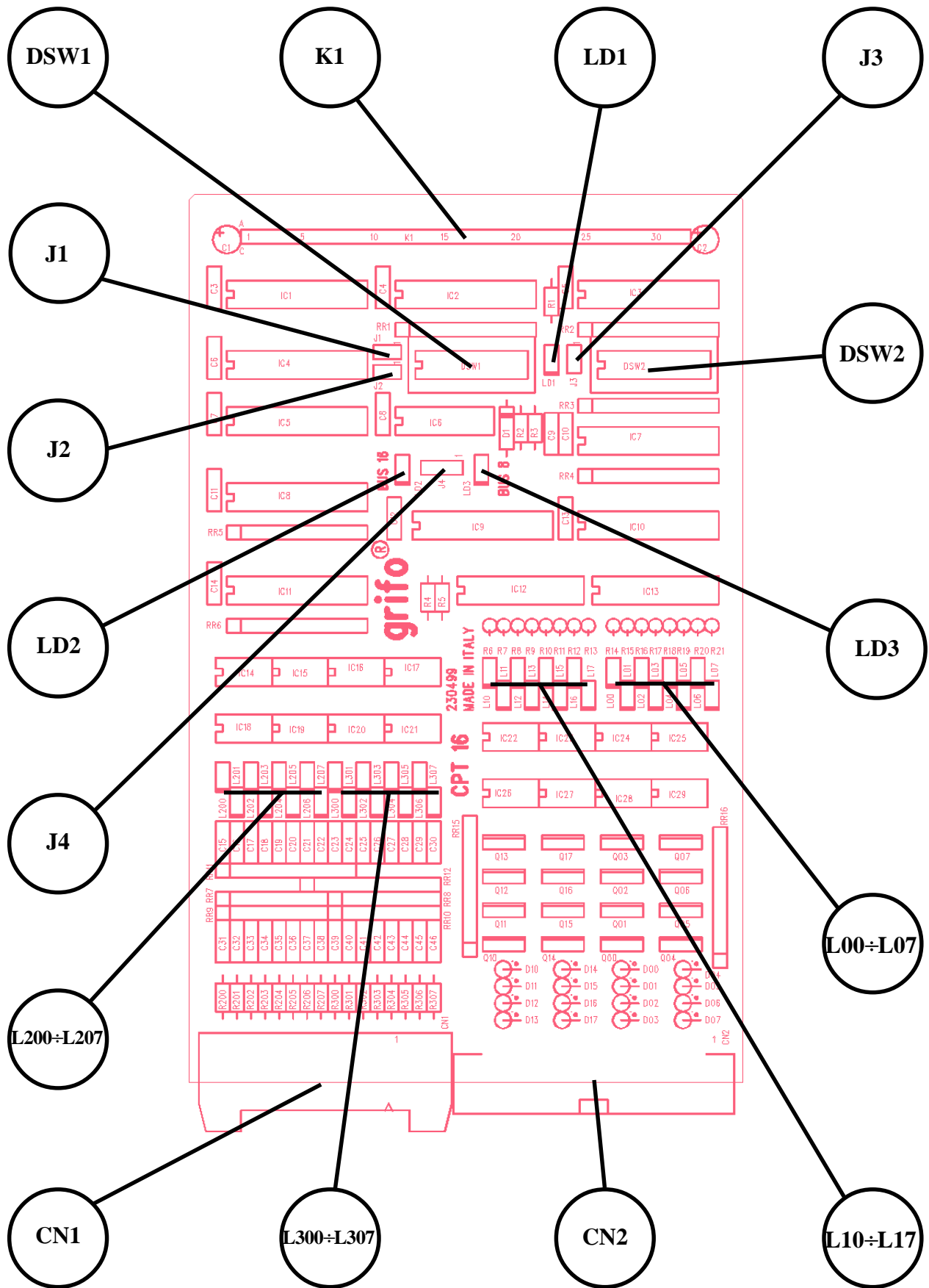

FIGURE 17: CPT 16 CONNECTORS, DIP SWITCHES, LEDs AND JUMPERS LOCATION

POWER SUPPLY

CPR 16 and **CPT 16** are provided with an efficient power supply circuitry that solves in an efficient and comfortable way the problem of board supply in any working condition.

Here follow the needed voltages, according to the board version:

CPR 16 POWER SUPPLY

Standard version CPR 16

- V opto:** Supplies the optocouplers in the input section of the board; must be in the range +12÷+24 Vdc and must be provided through pins 17-18 and 19-20 of CN1.
- +5 Vdc:** Supplies the control logic of the board; must be +5 Vdc \pm 5% and must be provided through the specific pins of connector K1 (BUS ABACO®).
- +12 Vdc:** Supplies the relays of the board; must be +12 Vdc \pm 5% and must be provided through the specific pins of connector K1 (BUS ABACO®).

Single supply version CPR 16.05

- V opto:** Supplies the optocouplers in the input section of the board; must be in the range +12÷+24 Vdc and must be provided through pins 17-18 and 19-20 of CN1.
- +5 Vdc:** Supplies the control logic and the relays of the board; must be +5 Vdc \pm 5% and must be provided through the specific pins of connector K1 (BUS ABACO®).

To warrant maximum noise immunity and so a correct working of the board, the **V opto** tension must be galvanically isolated from other tensions.

Please remark that the single supply version **CPR 16.05** allows to use a single stabilized tension to supply the whole system, however in this case the current consumption is greater.

CPT 16 POWER SUPPLY

- V opto:** Supplies the optocouplers of the input section; must be in the range +12÷+24 Vdc and must be provided through pins 17-18 and pins 19-20 of CN1.
- +5 Vdc:** Supplies the on board logic and the output transistors; must be in the range +5 Vdc \pm 5% and must be provided through the specific pins of connector K1 (BUS ABACO®).

To warrant great immunity to external noise and so a correct working of the board, it is essential that **V opto** tension is galvanically isolated.

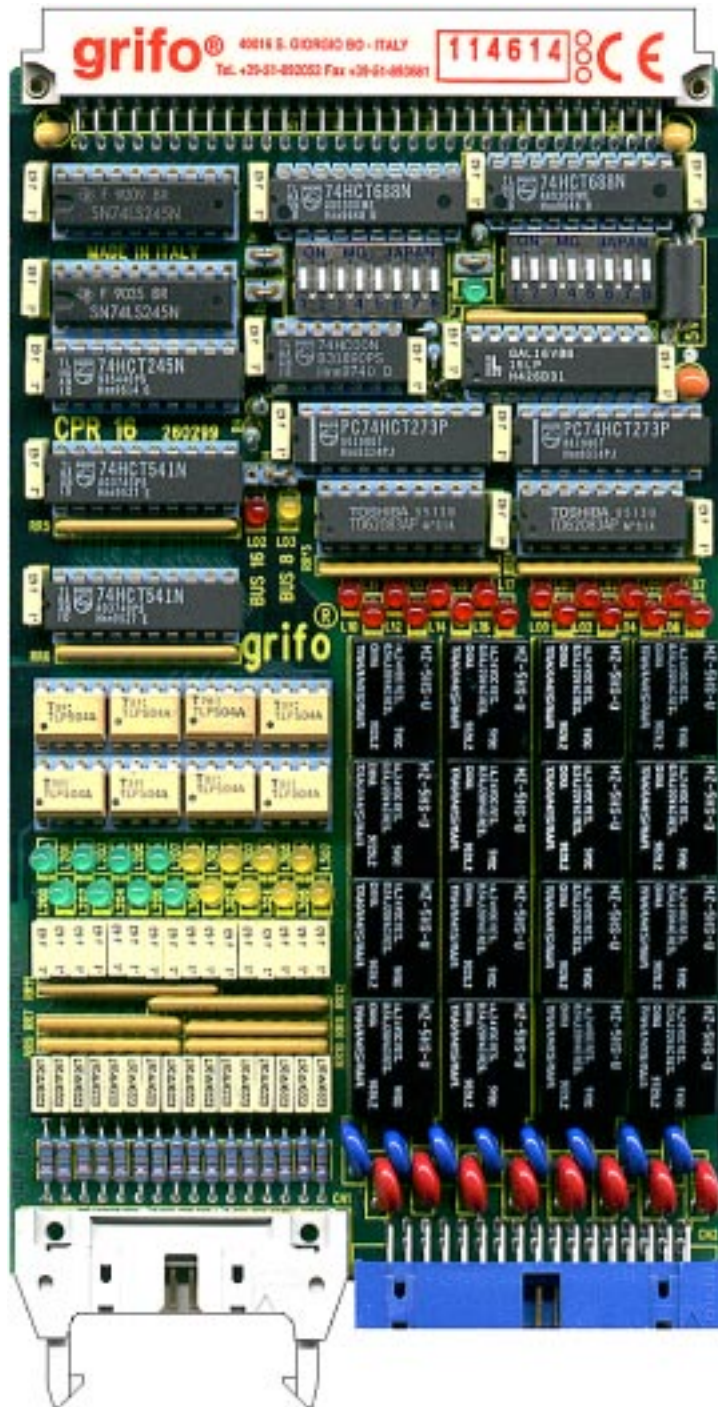

FIGURE 18: CPR 16 CARD PHOTO



HARDWARE DESCRIPTION

This chapter provides all the hardware informations needed to use **CPR16** and **CPT 16** boards. Here the User will find informations about I/O card mapping and on board peripheral devices addressing.

BOARD MAPPING

CPR16 and **CPT 16** boards are mapped into a **2** bytes I/O addressing space (or one word in 16 bits addressing mode), that can be mapped starting from different base addresses according to how the boards are configured. This feature allows to use several **CPR/T16** cards on the same **BUS ABACO®**, or to install them on a **BUS** where other peripheral modules are installed obtaining a structure that can be expanded without any difficulty or modifications to the application software. The base address can be defined through the specific **BUS** interface circuitry on the board itself; this circuitry uses the 2 eight pins dip switched called **DSW1** and **DSW2**, from which it reads the address set by the User. Here follows the corrispondance between dips configuration and address signals.

DSW1.1	->	<i>Don't care</i>	<i>8 bits BUS data path (J4 in position 1-2)</i>
		<i>Address A0</i>	<i>16 bits BUS data path (J4 in position 2-3)</i>
DSW1.2	->	Address A1	
DSW1.3	->	Address A2	
DSW1.4	->	Address A3	
DSW1.5	->	Address A4	
DSW1.6	->	Address A5	
DSW1.7	->	Address A6	
DSW1.8	->	Address A7	
DSW2.1	->	Address A8	
DSW2.2	->	Address A9	
DSW2.3	->	Address A10	
DSW2.4	->	Address A11	
DSW2.5	->	Address A12	
DSW2.6	->	Address A13	
DSW2.7	->	Address A14	
DSW2.8	->	Address A15	

These dips are driven in complemented logic, this means that if a dip is **ON** generates a **logic zero**, viceversa if a dip is **OFF** generates a **logic one**.

Jumper J3 selects the number of bytes addressed amongst which the allocation address can be chosen. If the 256 bytes (from 00H to FFH) normal addressing mode is selected, only DSW1 is significant (switches configuration on DSW2 is indifferent); if the 64Kbytes (from 00H to FFFFH) extended addressing mode is selected, then both DSW1 and DSW2 must be configured correctly.

Also jumper J1, described in the previous paragraph, affectes the addressing logic and must be connected accordind to the type of control card (**GPC®** serie) is used. In detail if the control card is provided with signal /M1 on the **BUS ABACO®** connector, then jumper J1 must be connected and viceversa.

NOTE

When allocating the mapping address of the boards, please be careful not to allocate more than one device in the same addressing space (count also the number of bytes occupied by the card). If this condition will not be respected, a BUS conflict will happen; such conflict will compromise the correct working of the whole system.

As an example, possible mappings are reported here.

- 1) Address used to map **CPR/T 16:** 04AH with 256 bytes addressing mode.
Control board used: data and addresses bus path are 8 bits wide;
provided with signal /M1.

J1	->	Connected
J3	->	Not connected
J4	->	Position 1-2
DSW1.1	->	Don't care
DSW1.2	->	OFF
DSW1.3	->	ON
DSW1.4	->	OFF
DSW1.5	->	ON
DSW1.6	->	ON
DSW1.7	->	OFF
DSW1.8	->	ON
DSW2	->	Don't care

- 2) Address used to map **CPR/T 16:** 14F8H with 64Kbytes addressing mode.
Control board used: data bus path is 8 bits wide;
addresses bus path is 16 bits wide;
not provided with signal /M1.

J1	->	Not connected
J3	->	Connected
J4	->	Position 1-2
DSW1.1	->	Indifferente
DSW1.2	->	ON
DSW1.3	->	ON
DSW1.4	->	OFF
DSW1.5	->	OFF
DSW1.6	->	OFF
DSW1.7	->	OFF
DSW1.8	->	OFF

DSW2.1	->	ON
DSW2.2	->	ON
DSW2.3	->	OFF
DSW2.4	->	ON
DSW2.5	->	OFF
DSW2.6	->	ON
DSW2.7	->	ON
DSW2.8	->	ON

3) Address used to map CPR/T 16:
Control board used:

F680H with 64Kbytes addressing mode.
data and addresses bus path are 16 bits wide;
not provided with signal /M1.

J1	->	Not connected
J3	->	Connected
J4	->	Position 2-3

DSW1.1	->	ON
DSW1.2	->	ON
DSW1.3	->	ON
DSW1.4	->	ON
DSW1.5	->	ON
DSW1.6	->	ON
DSW1.7	->	ON
DSW1.8	->	OFF

DSW2.1	->	ON
DSW2.2	->	OFF
DSW2.3	->	OFF
DSW2.4	->	ON
DSW2.5	->	OFF
DSW2.6	->	OFF
DSW2.7	->	OFF
DSW2.8	->	OFF

To easily locate jumpers and dip switches please refer to figures 15 and 17.

INTERNAL REGISTERS ADDRESSING

Indicating the board base address with **<baseaddr>**, that is the address set using Dip Switches DSW1 and DSW2, as indicated in the previous paragraph, **CI/O T16** internal registers are addressable as explained in the following tables, respectively when addressing mode is 8 bit and 16 bit.

NOTE

If using several boards on the same **BUS ABACO®**, when setting the boards mapping address the User should be careful not to allocate more than one board in the same addressing space (consider the base address plus the bytes taken by the board addressing). If this condition is not satisfied a BUS conflict situation will occur, prejudicing the correct working of the whole system.

INTERNAL REGISTERS ADDRESSING FOR 8 BIT ADDRESSING MODE

DEVICE	REG.	ADDRESS	R/W	PURPOSE
OUTPUT 0	OUT0	<baseaddr>+00H	W	Register to set the status of the 8 relay or transistor outputs in section OUT0.
OUTPUT 1	OUT1	<baseaddr>+01H	W	Register to set the status of the 8 relay or transistor outputs in section OUT1.
INPUT 0	IN0	<baseaddr>+00H	R	Register to read the status of the 8 optocoupled inputs in section IN0.
INPUT 1	IN1	<baseaddr>+01H	R	Register to read the status of the 8 optocoupled inputs in section IN1.

FIGURE 20: INTERNAL REGISTERS ADDRESSING TABLE FOR 8 BIT ADDRESSING MODE

INTERNAL REGISTERS ADDRESSING FOR 16 BIT ADDRESSING MODE

DEVICE.	REG.	ADDRESS	R/W	PURPOSE
OUTPUT	OUT	<baseaddr>+00H	W	Register to set the status of the 16 relay or transistor outputs in section OUT0 and OUT1.
INPUT	IN	<baseaddr>+00H	R	Register to read the status of the 16 optocoupled inputs in section IN0 and IN1.

FIGURE 21: INTERNAL REGISTERS ADDRESSING TABLE FOR 16 BIT ADDRESSING MODE

PERIPHERAL DEVICES SOFTWARE DESCRIPTION

In the previous paragraph allocation addresses of all the peripherals have been reported, here follows a detailed description of function and meaning of internal registers (please always refer to the peripheral mapping tables to understand completely the following informations). Should the present documentaion be inadequate please refer to the component's manufacturer documentation.

In the following paragraphs the indicatrions D0÷D7 or D0÷D15 are used to refer the bits of the combination used in the I/O operation.

RELAY OUTPUTS

Input/Output registers OUT0 and OUT1 are used to perform the output management on **CPR 16** board if the data BUS path is 8 bits wide. In case the data BUS path is 16 bits wide the register OUT is used. The bits of these registers have the following meaning:

8 bits data BUS

OUT1.D7 -> NO OUT1.7
 OUT1.D6 -> NO OUT1.6
 OUT1.D5 -> NO OUT1.5
 OUT1.D4 -> NO OUT1.4
 OUT1.D3 -> NO OUT1.3
 OUT1.D2 -> NO OUT1.2
 OUT1.D1 -> NO OUT1.1
 OUT1.D0 -> NO OUT1.0

OUT0.D7 -> NO OUT0.7
 OUT0.D6 -> NO OUT0.6
 OUT0.D5 -> NO OUT0.5
 OUT0.D4 -> NO OUT0.4
 OUT0.D3 -> NO OUT0.3
 OUT0.D2 -> NO OUT0.2
 OUT0.D1 -> NO OUT0.1
 OUT0.D0 -> NO OUT0.0

16 bits data BUS

OUT.D15 -> NO OUT1.7
 OUT.D14 -> NO OUT1.6
 OUT.D13 -> NO OUT1.5
 OUT.D12 -> NO OUT1.4
 OUT.D11 -> NO OUT1.3
 OUT.D10 -> NO OUT1.2
 OUT.D9 -> NO OUT1.1
 OUT.D8 -> NO OUT1.0

OUT.D7 -> NO OUT0.7
 OUT.D6 -> NO OUT0.6
 OUT.D5 -> NO OUT0.5
 OUT.D4 -> NO OUT0.4
 OUT.D3 -> NO OUT0.3
 OUT.D2 -> NO OUT0.2
 OUT.D1 -> NO OUT0.1
 OUT.D0 -> NO OUT0.0

The indication **NO OUTn.?** stands for OUT0 and OUT1 sections, whose output signals are available on connector CN2.

Performing an output operation at the address of OUT0, OUT1 or OUT the corresponding eight outputs are set by the output data, while performing an input operation at the same address the status of the corresponding signals is input.

The correspondance between status of an output and value of a bit is:

Bit at logic 0 -> Output disabled = Realy contact open
 Bit at logic 1 -> Output enabled = Realy contact closed

All the registers are reset (all bits are 0) when a Reset or a Power On occur if **J2** is connected, this disables all the outputs and opens all the relays contacts.

TRANSISTOR OUTPUTS

Input/Output registers (called OUT1 and OUT2 if BUS data path is 8 bits wide and called OUT if BUS data path is 16 bits wide) are used to perform the output management on **CPT 16** board. The bits of these registers have the following meaning:

BUS dati ad 8 bits

OUT1.D7 -> OC OUT1.7
 OUT1.D6 -> OC OUT1.6
 OUT1.D5 -> OC OUT1.5
 OUT1.D4 -> OC OUT1.4
 OUT1.D3 -> OC OUT1.3
 OUT1.D2 -> OC OUT1.2
 OUT1.D1 -> OC OUT1.1
 OUT1.D0 -> OC OUT1.0

OUT0.D7 -> OC OUT0.7
 OUT0.D6 -> OC OUT0.6
 OUT0.D5 -> OC OUT0.5
 OUT0.D4 -> OC OUT0.4
 OUT0.D3 -> OC OUT0.3
 OUT0.D2 -> OC OUT0.2
 OUT0.D1 -> OC OUT0.1
 OUT0.D0 -> OC OUT0.0

BUS dati a 16 bits

OUT.D15 -> OC OUT1.7
 OUT.D14 -> OC OUT1.6
 OUT.D13 -> OC OUT1.5
 OUT.D12 -> OC OUT1.4
 OUT.D11 -> OC OUT1.3
 OUT.D10 -> OC OUT1.2
 OUT.D9 -> OC OUT1.1
 OUT.D8 -> OC OUT1.0

OUT.D7 -> OC OUT0.7
 OUT.D6 -> OC OUT0.6
 OUT.D5 -> OC OUT0.5
 OUT.D4 -> OC OUT0.4
 OUT.D3 -> OC OUT0.3
 OUT.D2 -> OC OUT0.2
 OUT.D1 -> OC OUT0.1
 OUT.D0 -> OC OUT0.0

The indication **OC OUTn.?** stands for OUT0 and OUT1 sections, whose output signals are available on connector CN2.

Performing an output operation at the address of OUT0, OUT1 or OUT the corresponding outputs are set by the output data.

The correspondance between status of an output and value of a bit is:

Bit at logic 0 -> Output disabled = Open collector transistor deactivated
 Bit at logic 1 -> Output enabled = Open collector transistor actived

All registers are reset (all bits are 0) when a Reset or a Power On occur if **J2** is connected, this disables all the outputs and disables all the open collector transistors.

OPTOCOUPLED INPUTS

Input registers (called IN1 and IN2 if BUS data path is 8 bits wide and called IN if BUS data path is 16 bits wide) are used to perform the input management on **CPR 16** and **CPT 16** boards. The bits of these registers have the following meaning:

<i>8 bits data BUS</i>		<i>16 bits data BUS</i>		
IN1.D7	->	IN1.7		
IN1.D6	->	IN1.6		
IN1.D5	->	IN1.5		
IN1.D4	->	IN1.4		
IN1.D3	->	IN1.3		
IN1.D2	->	IN1.2		
IN1.D1	->	IN1.1		
IN1.D0	->	IN1.0		
IN0.D7	->	IN0.7		
IN0.D6	->	IN0.6		
IN0.D5	->	IN0.5		
IN0.D4	->	IN0.4		
IN0.D3	->	IN0.3		
IN0.D2	->	IN0.2		
IN0.D1	->	IN0.1		
IN0.D0	->	IN0.0		
		IN.D15	->	IN1.7
		IN.D14	->	IN1.6
		IN.D13	->	IN1.5
		IN.D12	->	IN1.4
		IN.D11	->	IN1.3
		IN.D10	->	IN1.2
		IN.D9	->	IN1.1
		IN.D8	->	IN1.0
		IN.D7	->	IN0.7
		IN.D6	->	IN0.6
		IN.D5	->	IN0.5
		IN.D4	->	IN0.4
		IN.D3	->	IN0.3
		IN.D2	->	IN0.2
		IN.D1	->	IN0.1
		IN.D0	->	IN0.0

The indication **INn.?** stands for IN1 and IN2 sections, whose input signals are available on connector CN1.

Performing an input operation at the address of IN1, IN2 or IN the corresponding optocoupled input signals are acquired.

The correspondance between status of an input and value of a bit is:

Bit at logic 0	->	Input disabled	=	Input contact open
Bit at logic 1	->	Input enabled	=	Input contact closed

EXTERNAL CARDS

CPR 16 and **CPT 16** boards can interface to most of **grifo**[®] industrial boards. Their main purpose is to perform a digital Inpu/Output interfacement between CPU (**GPC**[®]) cards and the external world. Here is reported an illustrative list of cards capable to interact with **CPR 16** e **CPT 16** boards with a short description of their features; for further informations please request the specific documentation.

MB3 01-MB4 01-MB8 01

Mother Board 3, 4, 8 slots

Motherboard featuring 3, 4 or 8 slots of **ABACO**[®] industrial BUS; pitch 4 TE; standard power supply connectors; LEDs for visual feed-back of power supply; holes for rack docking.

SPB 04-SPB 08

Switch Power BUS 4-8 slots

Motherboard featuring 4-8 slots of **ABACO**[®] industrial BUS; pitch 4 TE; standard power supply connectors; termination resistances; connector type F for **SPC xxx** supply ; holes for rack docking.

ABB 03

ABACO[®] Block BUS 3 slots

3 slots **ABACO**[®] mother board; 4 TE pitch connectors; **ABACO**[®] I/O BUS connector; screw terminal for power supply; connection for DIN C type and Ω rails.

ABB 05

ABACO[®] Block BUS 5 slots

5 slots **ABACO**[®] mother board with power supply. Double power supply built in; 5Vdc 2,5A section for powering the on board logic; second section at 24Vdc 400mA galvanically coupled, for the optocoupled input lines. Auxiliary connector for **ABACO**[®] I/O BUS. Connection for DIN Ω rails.

SBP 02-xx

Switch BLOCK Power xx version

Low cost switching power supply able to generate voltage from +5 to +40 Vdc and current up to 2.5 A; Input from 12 to 24 Vac; Connection for DIN C Type and Ω rails.

SPC 03.5S

Switch Power Card +5 Vdc

Europe format switching power supply capable to provide +5 Vdc to a load of 4 A; input voltage 12÷24 Vac; power-failure; connector for back-up battery; standard connector for mother board **SPB 0x**.

SPC 512

Switch Power Card +5 Vdc +12 Vdc

Europe format switching power supply capable to provide +5 Vdc 5A and +12 Vdc 2.5 A; input voltage 12÷24 Vac; power-failure; connector for back-up battery; standard connector for mother board **SPB 0x**.

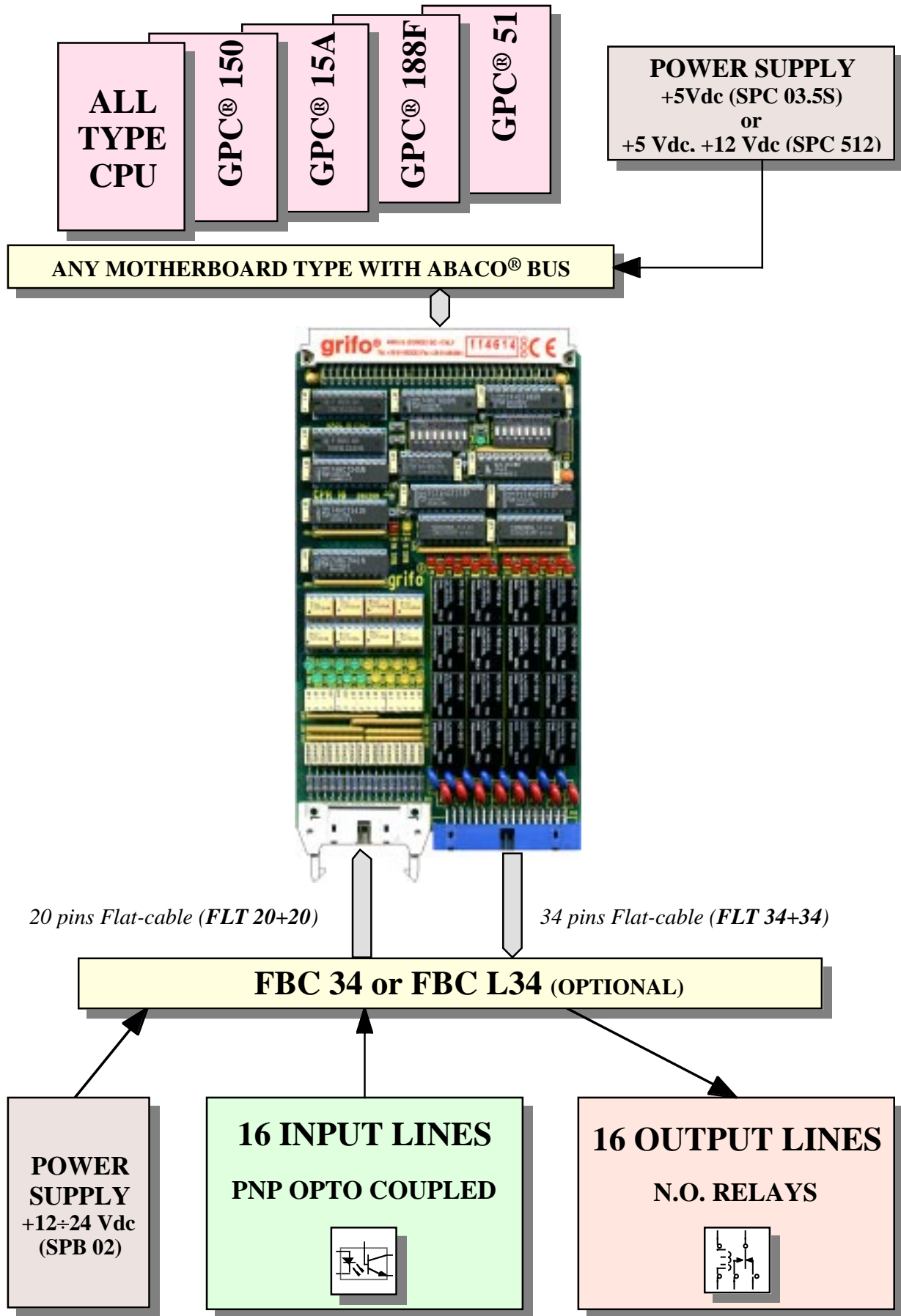

FIGURE 22: CPR 16 POSSIBLE CONNECTIONS DIAGRAM

GPC® 51

General Purpose Controller fam. 51

Microprocessor family 51 INTEL including the masked BASIC chip; the board features: 16 I/O TTL lines; dip switch; 3 timer/counter; RS 232; 4 A/D converter signals resolution 11 bit; buzzer; on board EPROM programmer; RTC and 32K SRAM with Lithium battery back up; controller for display and keyboard.

GPC® 188F

General Purpose Controller 80C188

80C188 μ P 20MHz; 1 RS 232 line; 1 RS 232, RS 422-485 or Current Loop line; 24 TTL I/O lines; 1M EPROM or 512K FLASH; 1M RAM Lithium battery backed; 8K serial EEPROM; RTC; Watch Dog; 8 Dip switch; 3 Timer Counter; 8 13 bit A/D lines; Power failure; activity LEDs; single power supply +5Vdc.

GPC® 15A

General Purpose Controller 84C15

Full CMOS card, 10÷20 MHz 84C15 CPU; 512K EPROM or FLASH; 128K RAM; 8K RAM and RTC backed; 8K serial EEPROM; 1 RS 232 line; 1 RS 232 line or RS 422-485 or Current Loop line; 32 or 40 TTL I/O lines; CTC; Watch dog; 2 Dip switches; Buzzer.

GPC® 150

General Purpose Controller 84C15

Microprocessor Z80 at 16 MHz; implementation completely CMOS; 512K EPROM or FLASH; 512K SRAM; RTC; Back-Up through external Lithium battery; 4M serial FLASH; 1 serial line RS 232 plus 1 RS 232 or RS 422-485 or current loop; 40 I/O TTL; 2 timer/counter; 2 watch dog; dip switch; EEPROM; A/D converter with resolution 12 bit; activity LED.

GPC® 15R

General Purpose Controller 84C15

84C15 μ P, 10÷16 MHz; 1 RS 232 line; 1 RS 232 or RS 422-485 or C. L. line; 16÷24 TTL I/O lines; 16 Opto-in; 8 Relays; 4 Opto Coupled Timers Counters; 512K EPROM or FLASH; 512K RAM and RTC backed; 8K serial EEPROM; 8K Backed RAM modul; Buzzer; 1 Activity LED; Watch dog; 4÷12 readable DIPs; LCD Interface.

GPC® 323

General Purpose Controller 51 family

80C32 μ P, 14 MHz; Full CMOS; 1 RS 232 line (software); 1 RS 232 or RS 422-485 or Current Loop line; 24 TTL I/O lines; 11 A/D 12 bits lines; 3 Timers Counters; 64K EPROM; 64K RAM; 32K RAM and RTC backed; 32K DIL EEPROM; 8K serial EEPROM; Buzzer; 2 Activity LED; Watch dog; 5 readable DIPs; LCD Interface.

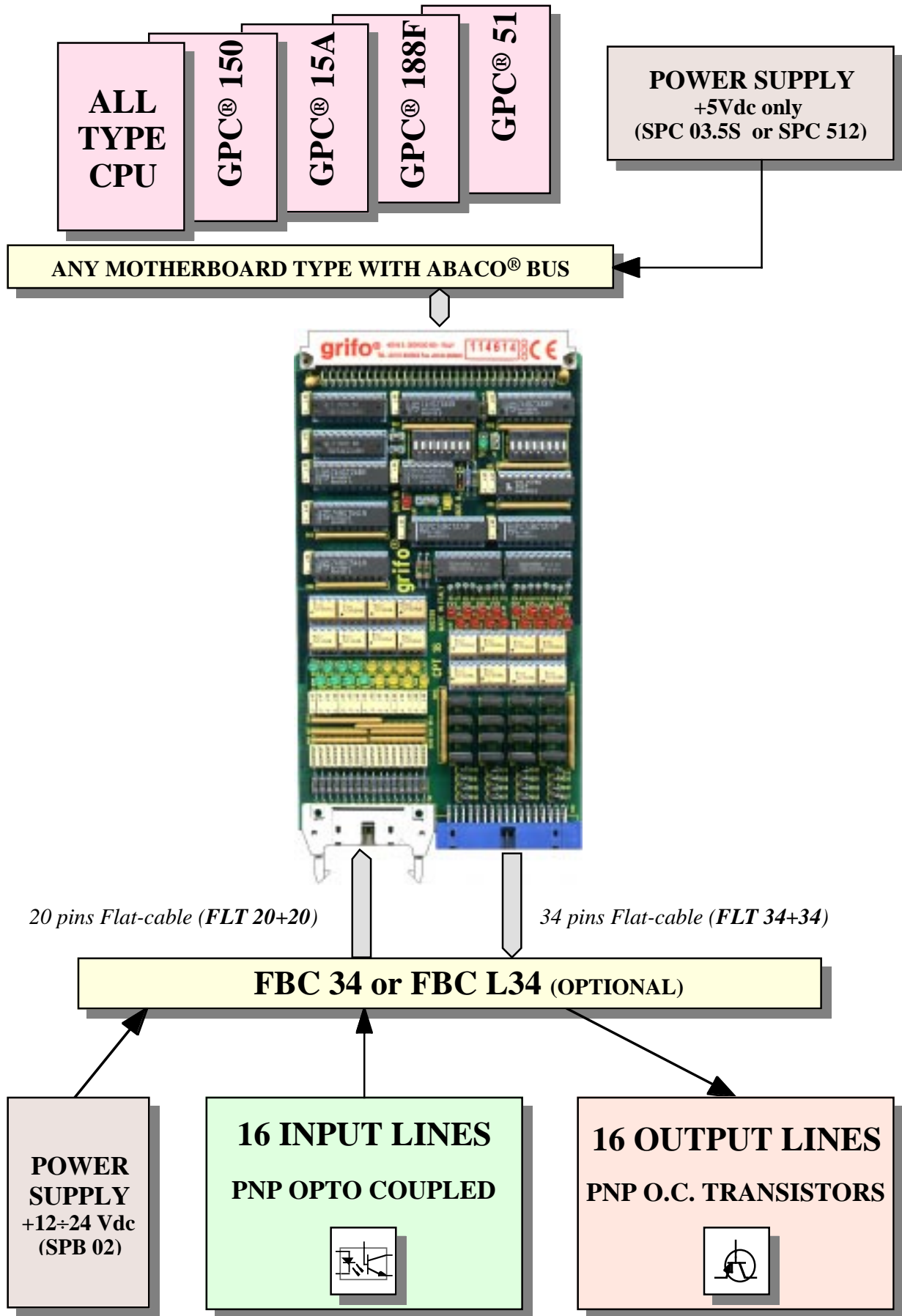

FIGURE 23: CPT 16 POSSIBLE CONNECTIONS DIAGRAM

GPC® 553

General Purpose Controller 80C552

80C552 μ P, 22÷33 MHz; 1 RS 232 line (software); 1 RS 232 or RS 422-485 or Current Loop line; 16 TTL I/O lines; 8 A/D 10 bits lines; 3 Timers Counters; 64K EPROM; 64K RAM; 32K RAM and RTC backed; 32K DIL EEPROM; 8K serial EEPROM; 2 PWM lines; 1 Activity LED; Watch dog; 5 readable DIPs; LCD Interface.

GPC® 153

General Purpose Controller Z80

84C15 μ P, 10÷16 MHz; Full CMOS; 1 RS 232 line; 1 RS 232 or RS 422-485 or Current Loop line; 16 TTL I/O lines; 8 A/D 12 bits lines; 2÷4 Timers Counters; 512K EPROM or FLASH; 512K RAM and RTC backed; 8K serial EEPROM; Buzzer; 1 Activity LED; Watch dog; 8 readable DIPs; LCD Interface.

GPC® 183

General Purpose Controller Z180

Z180 μ P, 10÷16 MHz; Full CMOS; 1 RS 232 line; 1 RS 232 or RS 422-485 or Current Loop line; 24 TTL I/O lines; 11 A/D 12 bits lines; 2 Timers Counters; 512K EPROM or FLASH; 512K RAM and RTC backed; 8K serial EEPROM; Buzzer; 2 Activity LED; Watch dog; 4 readable DIPs; LCD Interface.

GPC® 324/D

“4” Type General Purpose Controller 80C32/320

80C32 or 80C320 μ P, 14÷22 MHz; Full CMOS; 1 RS 232 line; 1 RS 232 or RS 422-485 or Current Loop line; 4÷16 TTL I/O lines; 3 Timers Counters; 64K EPROM; 64K RAM; 32K RAM backed; 32K DIL E2; 8K serial EEPROM; Watch dog; 1 readable DIP; LCD Interface; Abaco® I/O BUS; 5Vdc Power supply; Size: 100x50 mm.

GPC® 554

General Purpose Controller 80C552

Microprocessor 80C552 at 22 MHz; implementation completely CMOS; 32K EPROM; 32 K SRAM; 32 K EEPROM or SRAM; EEPROM; 2 RS 232 serial lines; 16 I/O TTL; 2 PWM lines; 16 bits Timer/Counter; Watch Dog; 6 signals A/D converter with resolution 10 bit; interface for **ABACO®** I/O BUS.

GPC® 154

“4” Type General Purpose Controller Z80

84C15 μ P, 10÷16 MHz; Full CMOS; 1 RS 232 line; 1 RS 232 or RS 422-485 line; 16 TTL I/O lines; 2÷4 Timers Counters; 512K EPROM or FLASH; 512K RAM and RTC backed; 8K serial EEPROM; Watch dog; 2 readable DIPs; LCD Interface; Abaco® I/O BUS; 5Vdc Power supply; Size: 100x50 mm.

GPC® 884

General Purpose Controller Am188ES

Microprocessor AMD Am188ES up to 40 MHz; 16 bits; implementation completely CMOS; serie 4 format; 512K EPROM or FLASH; 512K SRAM backed with Lithium battery; RTC; 1 RS 232 serial line + 1 RS 232 or RS 422-485 or current loop; 16 I/O TTL; 3 timer/counter; watch dog; EEPROM; 11 signals A/D converter with 12 bit resolution; interface for **ABACO®** I/O BUS.

GPC® 114

General Purpose Controller 68HC11

Microprocessor 68HC11A1 at 8 MHz; implementation completely CMOS; serie 4 format; 32K EPROM; 32K SRAM backed with Lithium battery; 32K EPROM, SRAM, EEPROM; RTC; 1 serial line RS 232 or RS 422-485; 10 I/O TTL; 3 timer/counter; watch dog; 8 signals A/D converter with resolution 8 bit; 1 asynchronous serial line; extremely low power consumption; interface for **ABACO®** I/O BUS.

FBC 20-120

Flat Block Contact 20 vie

Interface for 2 or 1 mounting cable connectors (low profile 20 pins male) and quick release screw terminal connectors; Plastic mount for rails DIN 46277-1 and 3.

FBC 34

Flat Block Contact 34 vie

Interface for 2 mounting cable connector (low profile 34 pins male) and quick release screw terminal connectors; Plastic mount for rails DIN 46277-1 and 3.

FBC L20

Flat Block Contact LED 20 vie

Interface for 1 mounting cable connector (low profile 20 pins male, featuring **ABACO®** standard Input pin out, and quick release screw terminal connectors; All the signals are visualized through LEDs; Plastic mount for rails DIN 46277-1 and 3.

FBC L34

Flat Block Contact LED 34 vie

Interface for 2 mounting cable connectors (low profile 34 and 20 pins male) and quick release screw terminal connectors; featuring **ABACO®** standard Input and Output pin out; All the signals are visualized through LEDs; Plastic mount for rails DIN 46277-1 and 3.

BIBLIOGRAPHY

Here follows a list of manuals and technical notes that the User can read to acquire more informations about **CPR 16** and **CPT 16** boards.

Manual SGS-THOMSON: *Industrial and Computer Peripheral ICs - Data Book*

Manual SGS-THOMSON: *Programmable logic manual - GAL Products*

Manual TEXAS INSTRUMENTS: *The TTL data Book - SN54/74 Families*

Manual TOSHIBA: *Photo Couplers - Data Book*

Manual MOTOROLA: *Bipolar Power Transistor Data*

Please connect to the manufactures Web sites to get the latest version of all manuals and data sheets.

APPENDIX A: ALPHABETICAL INDEX

SYMBOLS**+V OPTO 24****/RESET 20****B****BIBLIOGRAPHY 42****BOARD MAPPING 28****BUS ABACO® 2, 4, 18, 26, 28, 32****C****CARD VERSION 1****CONNECTIONS 12****CONNECTORS 8, 10****CN1 12****CN2 14, 16****K1 18****CONTROL LOGIC 4****CPR 16 ELECTRIC FEATURES 7****CPR 16 GENERAL FEATURES 7****CPR 16 PHYSICAL FEATURES 8****CPR 16 TECHNICAL FEATURES 7****CPT 16 ELECTRIC FEATURES 9****CPT 16 GENERAL FEATURES 9****CPT 16 PHYSICAL FEATURES 10****CPT 16 TECHNICAL FEATURES 9****CURRENT CONSUMPTION 7, 9****D****DARLINGTON PNP 2, 9, 16, 24****DIP SWITCHES 7, 32****DSW1 32****DSW2 32****E****EMF PROTECTION 6, 9****EXTERNAL CARDS 36****F****FILTER 2, 7, 9**

G

GENERAL INFORMATIONS 2

GPC® 19, 36

H

HARDWARE DESCRIPTION 28

I

I/O CONNNECTIONS 24

INPUT SECTION 6

INSTALLATION 12

INTERFACING AND ADDRESSING SECTION 4

INTERNAL REGISTERS ADDRESSING 32

INTERNAL REGISTERS ADDRESSING FOR 16 BIT ADDRESSIN 32

INTERNAL REGISTERS ADDRESSING FOR 8 BIT ADDRESSING 32

INTRODUCTION 1

J

JUMPERS 22

2 PINS JUMPERS 22

3 PINS JUMPERS 24

L

LEDS 2, 20

M

MAX CURRENT ON THE RELAY CONTACT 7

MAX CURRENT ON TRANSISTOR 9

MAX POWER EACH TRANSISTOR 9

MAX VOLTAGE ON THE RELAY CONTACT 7

MAX VOLTAGE ON TRANSISTORS 9

MINIMUM CURRENT FOR PNP INPUTS 7, 9

MOV 4, 7, 15

N

N. ADDRESSABLE BYTES 7, 9

O

ON BOARD RESOURCES 7, 9

OPTOCOUPLED PNP INPUTS 2, 7, 9, 12, 24, 35

P

PERIPHERAL DEVICES SOFTWARE DESCRIPTION 33
POWER SUPPLY 7, 9, 26

R

RELATIVE HUMIDITY 8, 10
RELAYS OUTPUTS 2, 4, 7, 14, 24, 33
RELAYS PROTECTION 7
RESET CIRCUITRY 20

S

SIZE 8, 10

T

TEMPERATURE RANGE 8, 10
TRANSISTOR OUTPUTS 6, 34
TRANSISTOR PROTECTION 9
TTL SIGNALS 24

V

VISUAL SIGNALATIONS 20

W

WEIGHT 8, 10

