

APPENDIX A: CARD ASSEMBLY

The **GPC® F2** can be ordered in two different mode: completely mounted, tested and ready to use or in assembly kit. In this final condition the user can directly use the information of this chapter.

COMPONENTS LIST

In the following paragraphs there are the components lists divided according with the card sections. Please remember that only the base component are really necessary, while all the others are options and they can be mounted only if required by the user.

BASE COMPONENTS

Soldered:

BZ1 - Passive piezo electric buzzer.

CN3 - 16 pins, 90°, low profile connector.

C1, C2, C15, C16, C19, C27, C37 - 22 μ F 6,3V tantalum capacitor .

C3, C4, C5, C6, C7, C8, C9, C10, C13, C14, C20, C21, C22, C28 - 100 KpF multi layered capacitor.

C11, C12 - 22 pF NP0 ceramic capacitor.

C17, C18 - 22 μ F 16V tantalum capacitor.

D1, D3 - 1N4148 diode.

IC1, IC2, IC4, IC5 - 20 pins, d.i.l., low profile socket.

IC3, IC11, IC18 - 16 pins, d.i.l., low profile socket.

IC6 - 40 pins, d.i.l., low profile socket.

IC7, IC8, IC9, IC10 - 28 pins, d.i.l., low profile socket.

IC12, IC13, IC14 - 14 pins, d.i.l., low profile socket.

J1, J8 - 2 pins , 2.54 mm pitch, male strip.

J2, J3, J4, J5, J6 - 3 pins , 2.54 mm pitch, male strip.

K1 - DIN 41612, 64 pins, 90°, male, case C, type A+C connector (fixed with 2 screw).

LD1 - 3 mm yellow LED.

RR1, RR2, RR3, RR4, RR5 - 10 K Ω , 10 pins (9 commoned) resistor network.

R10 - 10 K Ω , 1/4 W resistor.

R7 - 47 K Ω , 1/4 W resistor.

R12 - 270 Ω , 1/4 W resistor.

XTL1 - 11.0592 MHz, HC49 crystal.

On socket:

IC1, IC5 - 74 LS 245.

IC4 - 74 HCT 245.

IC2 - 74 LS 373.

IC3 - N82S123 burned model "BS" or "BU".

IC18 - N82S123 burned model "18".

IC6 - CPU 8052 AH BASIC, 80C32, 80C320 etc.

IC7 - RAM D4364 (8K), EPROM 27c64 (8K) or 27c256 (32K).

IC8 - RAM D4364 (8K) or D43256 (32K).

IC9, IC10 - EPROM 27c64 (8K) or 27c128 (16K).

IC11 - MAX202.

IC12 - 74 HCT 08.

IC13 - 74 HCT 14.

IC14 - 7407.

Jxx - 8 two pins female jumpers for male strip.

PT 82C54 COMPONENTS

Soldered:

CN1 - 20 pins, 90°, low profile connector.

C29, C30 - 100 KpF multi layered capacitor.

C39 - 22 µF 6,3V tantalum capacitor.

IC19, IC20 - 24 pins, d.i.l., low profile socket.

R8, R11 - 10 KΩ, 1/4 W resistor.

RR7, RR8 - 10 KΩ, 10 pins (9 commoned) resistor network.

On socket:

IC19, IC20 - PT 82c54.

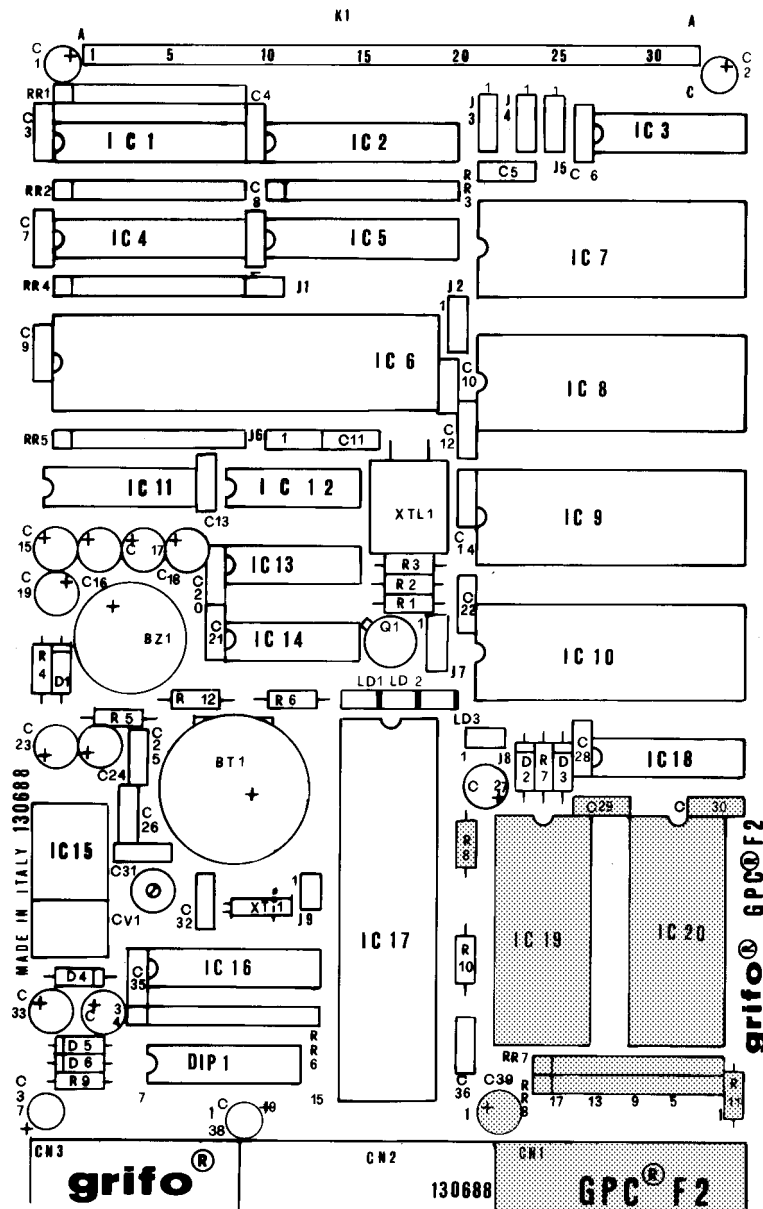

FIGURE A-1: COMPONENTS MAP FOR PT 82C54 SECTION



PPI 82C55 COMPONENTS

Soldered:

- CN2 - 20 pins, 90°, low profile connector.
- C36 - 100 KpF multi layered capacitor.
- C38 - 22 µF 6,3V tantalum capacitor.
- DIP 1 - 16 pins, d.i.l., low profile socket.
- IC17 - 40 pins, d.i.l., low profile socket.
- RR6 - 10 KΩ, 10 pins (9 commoned) resistor network.

On socket:

- IC17 - PPI 82c55.
- DIP1 - 8 SPST dip switch.

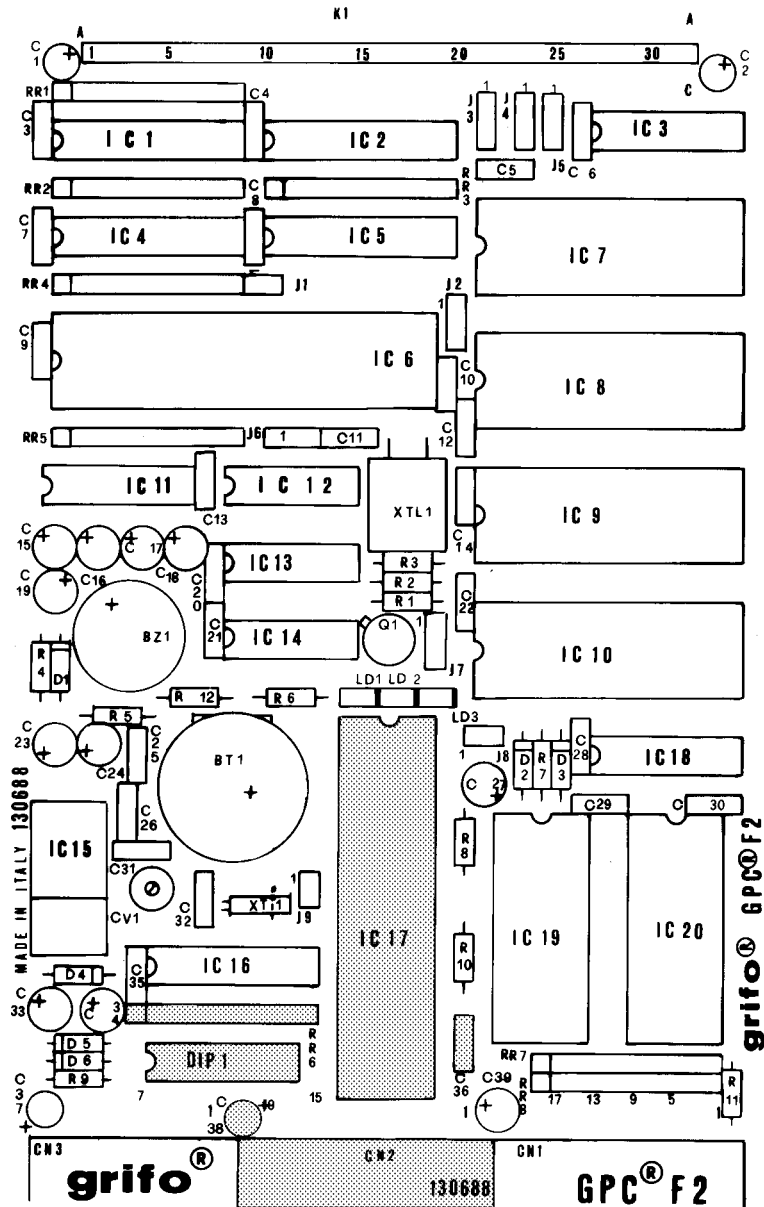

FIGURE A-2: COMPONENTS MAP FOR PPI 82C55 SECTION



RTC COMPONENTS

Soldered:

- CV1, C31 - 22 pF NP0 ceramic capacitor.
- C32 - 4,7 pF NP0 ceramic capacitor.
- C33,C34 - 22 µF 6,3V tantalum capacitor.
- C35 - 100 KpF multi layered capacitor.
- BT1 - 3V or 3.6V lithium battery, tipe TADIRAN TL586 or SAFT LM 2032 90°
- D4, D5, D6 - 1N4148 diode.
- IC16 - 18 pins, d.i.l., low profile socket.
- J9 - 2 pins , 2.54 mm pitch, male strip.
- R9 - 47 KΩ, 1/4 W resistor.
- XT1 - 32.384 KHz, cylindrical crystal (fixed with wire).

On socket:

- IC16 - OKI M6242B.

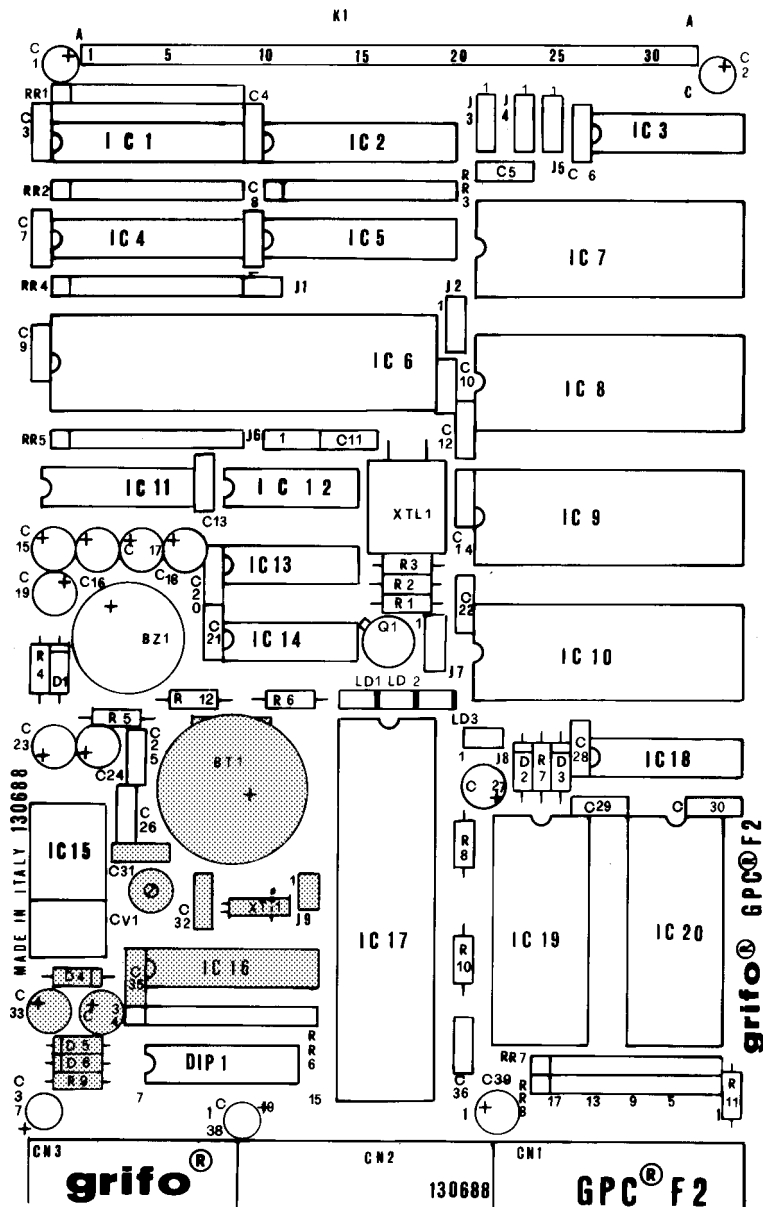

FIGURE A-3: COMPONENTS MAP FOR RTC SECTION



EPROM BURNING COMPONENTS

Soldered:

- C23 - 22 µF 6,3V tantalum capacitor.
- C24 - 22 µF 25V radial wire electrolytic capacitor.
- C25, C26 - 100 KpF multi layered capacitor.
- D2 - 1N4148 diode.
- IC15 - LM7806, TO220 case, voltage regulator.
- J7 - 3 pins , 2.54 mm pitch, male strip.
- LD2 - 3 mm red LED.
- LD3 - 3 mm green LED.
- Q1 - 2N2907 transistor.
- R1, R2, R3 - 10 KΩ, 1/4 W resistor.
- R4 - 1 KΩ, 1/4 W resistor.
- R5 - 820 Ω, 1/4 W resistor.
- R6 - 330 Ω, 1/4 W resistor.

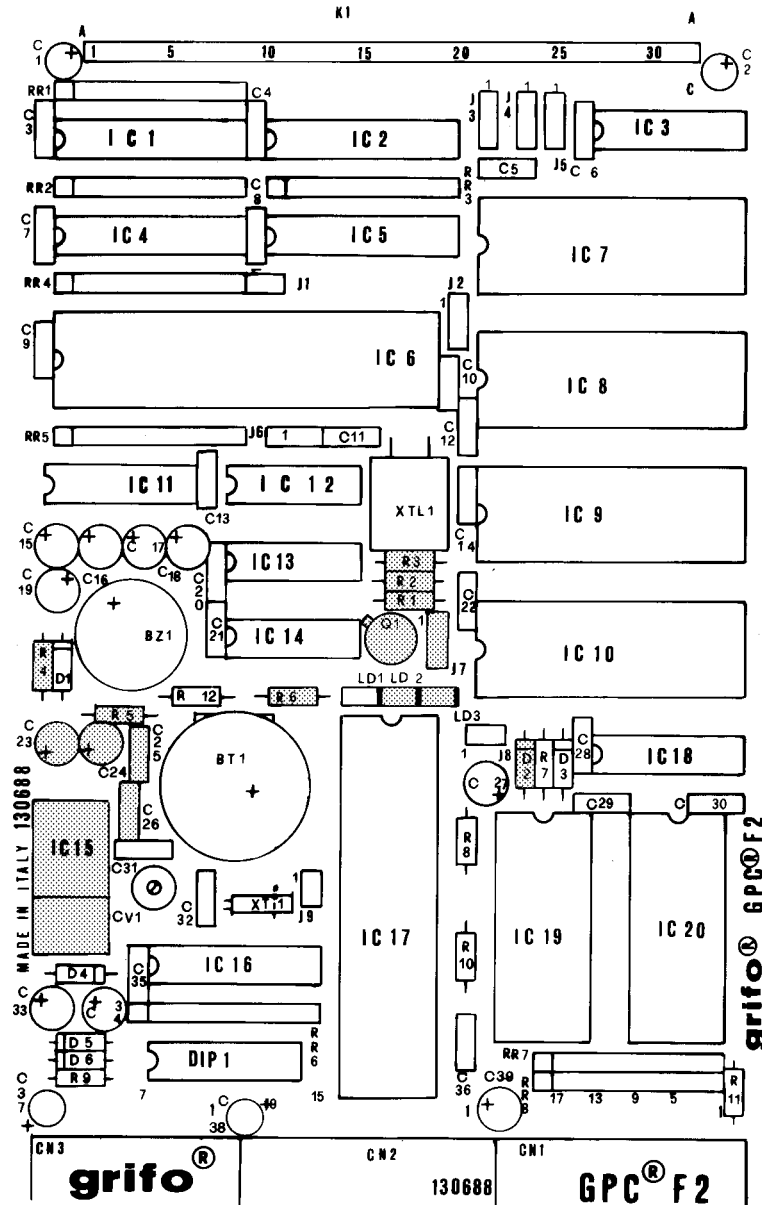

FIGURE A-4: COMPONENTS MAP FOR EPROM BURNING SECTION



ELECTRIC DIAGRAM

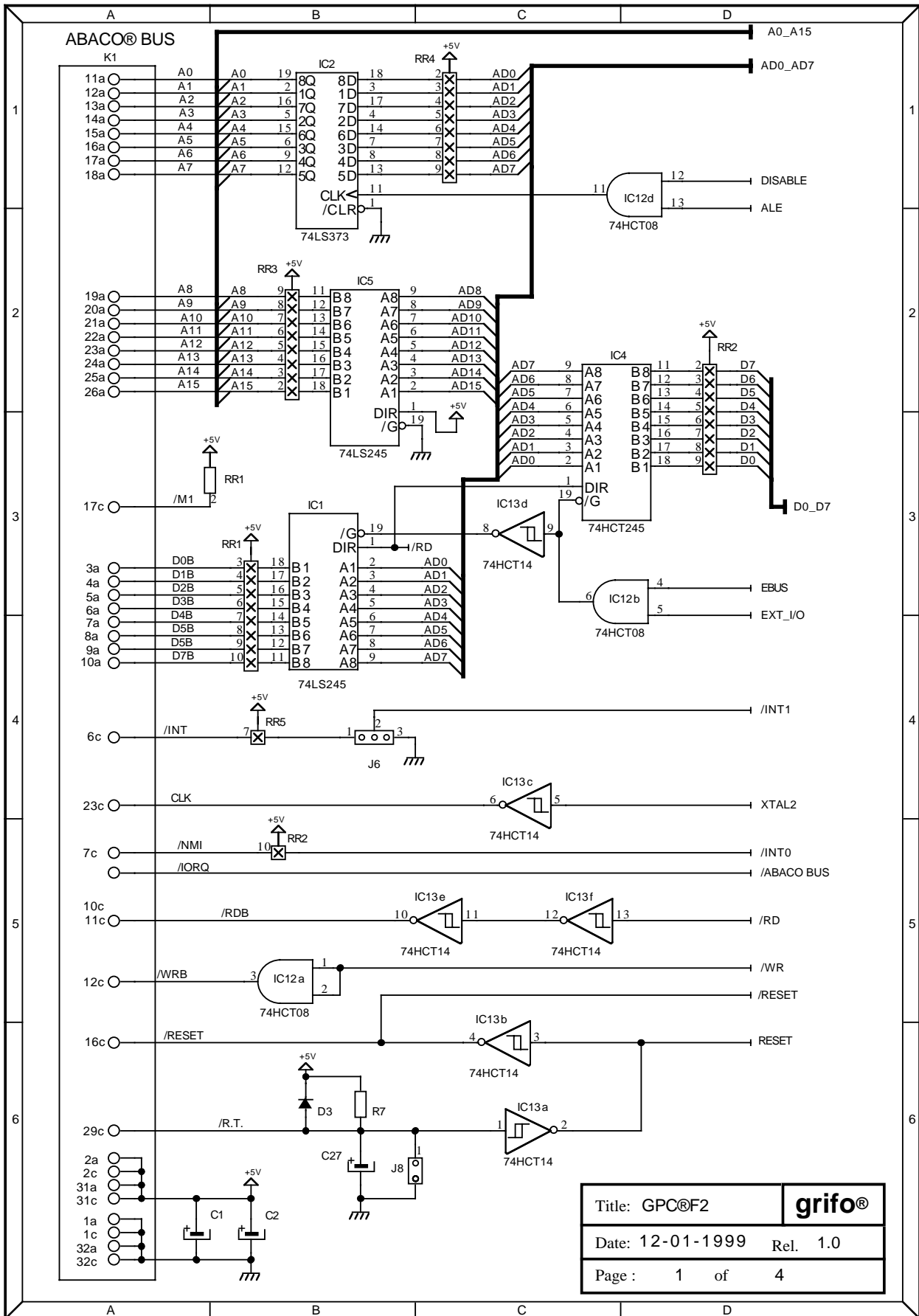

FIGURE A-5: ELECTRIC DIAGRAM 1 OF 4



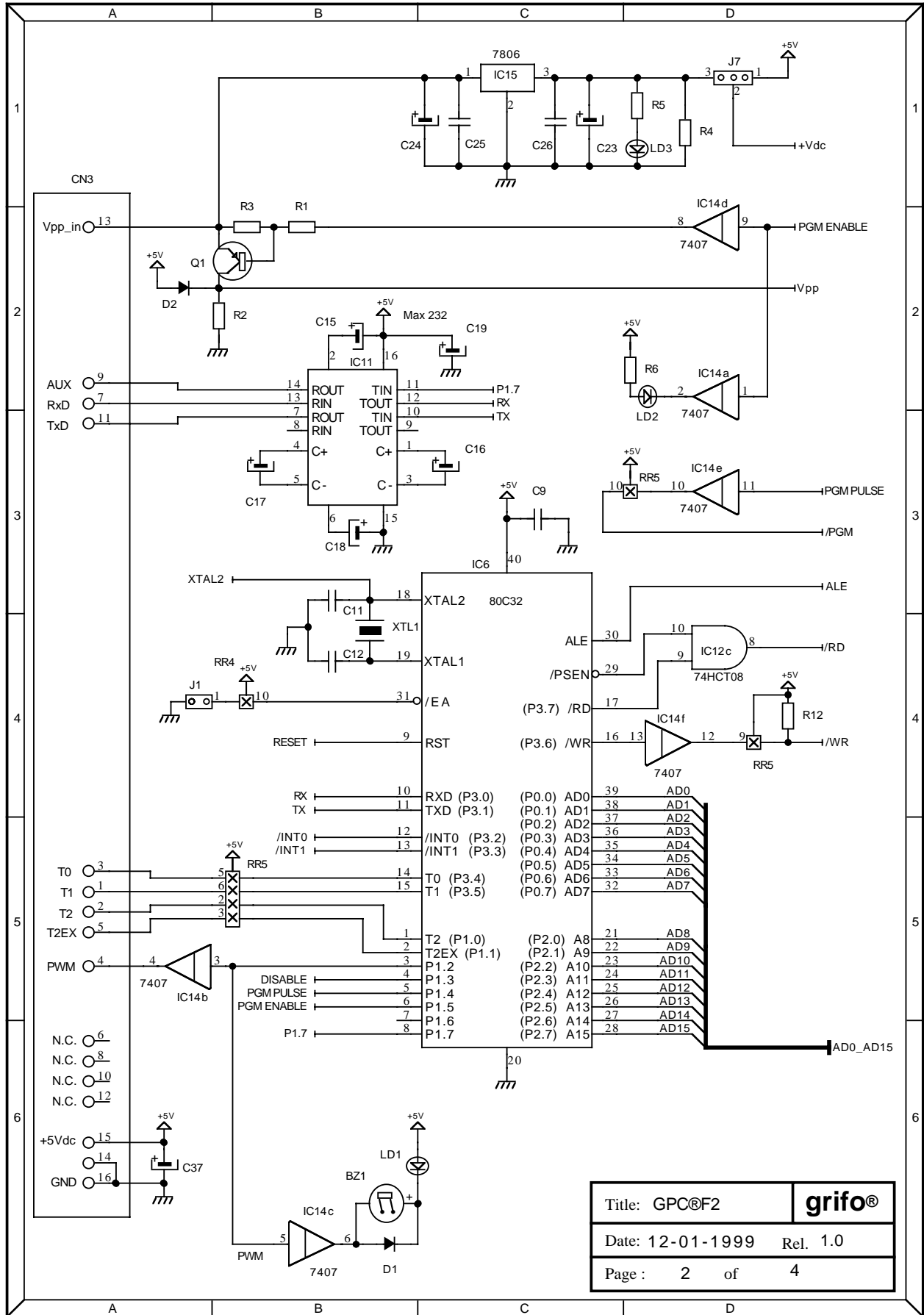
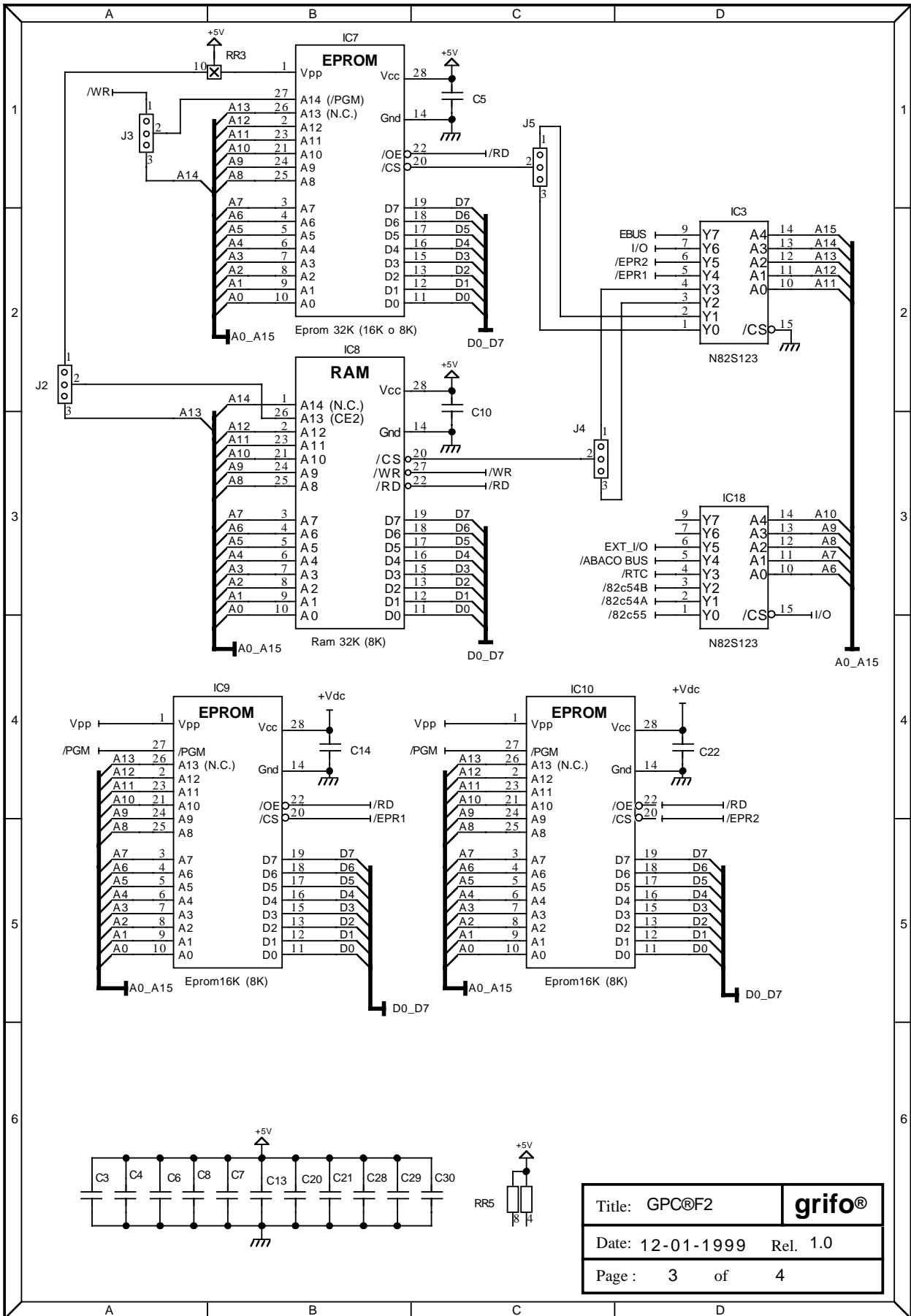

FIGURE A-6: ELECTRIC DIAGRAM 2 OF 4





Title: GPC®F2	grifo®
Date: 12-01-1999	Rel. 1.0
Page : 3	of 4

FIGURE A-7: ELECTRIC DIAGRAM 3 OF 4



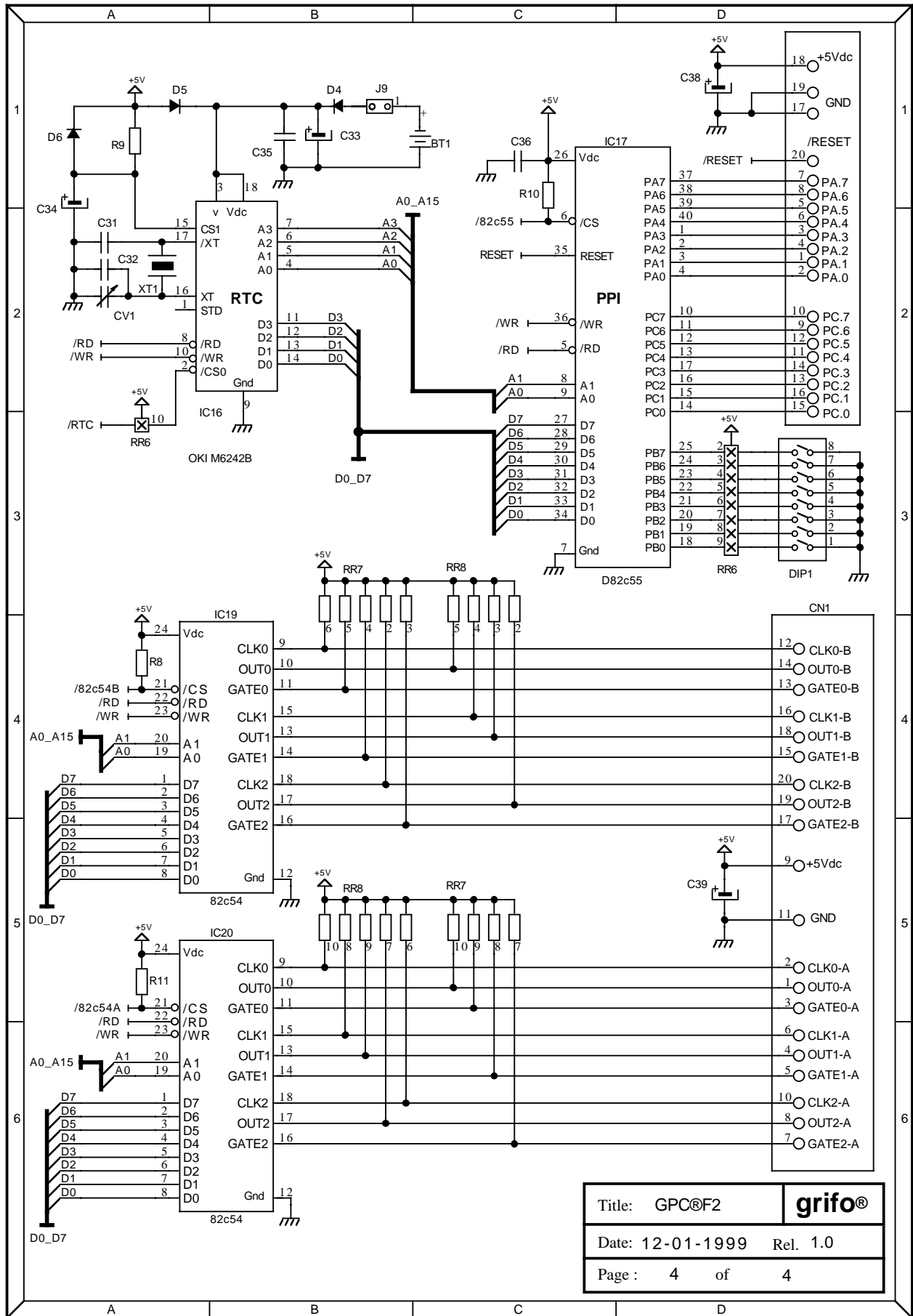

FIGURE A-8: ELECTRIC DIAGRAM 4 OF 4



