

GMM TST

grifo® Mini Module Test

TECHNICAL MANUAL

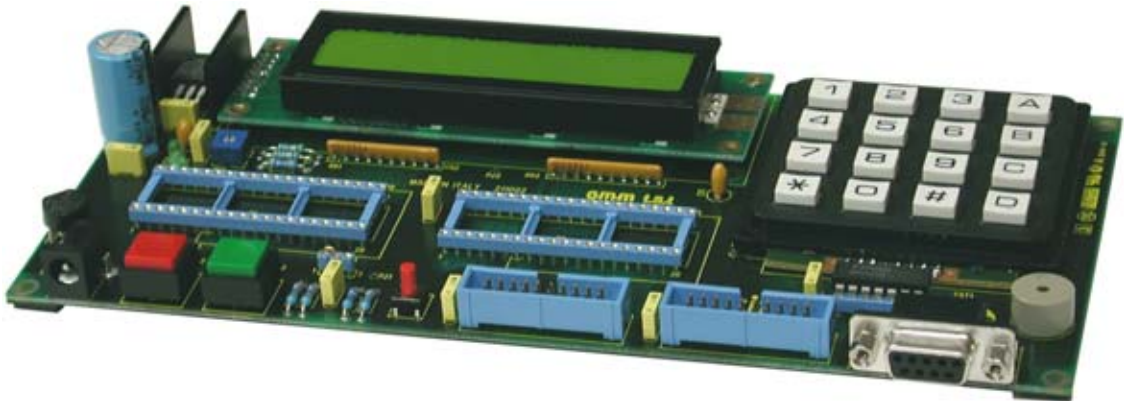

grifo®
ITALIAN TECHNOLOGY

Via dell' Artigiano, 8/6
40016 San Giorgio di Piano
(Bologna) ITALY
E-mail: grifo@grifo.it



<http://www.grifo.it> <http://www.grifo.com>
Tel. +39 051 892.052 (a. r.) FAX: +39 051 893.661

GMM TST

Rel. 5.00

Rel. 22 January 2003

, GPC®, grifo®, are trade marks of grifo®



GMM TST

grifo® Mini Module Test

TECHNICAL MANUAL

Two 40 pins dual in line female socket (100 mils pitch, 600 mils width) capable to accommodate 28 pins or 40 pins **grifo®** Mini Modules type **GMM AC2**, **GMM 5115**, **CAN GM1**, **CAN GM2**, etc.; standard jack 2,1 mm power supply connector; power supply section that accept an input voltage in the range **7÷12V AC or DC**, compatible with the greater part of low cost main adaptors; **LED** on +5 Vdc voltage, generated by power supply section; **RESET** push button; **Buzzer** for acoustic signal driven by Mini Module; DB9 female connector with **RS 232** serial line; up to **32 TTL I/O lines** of Mini Module are connected to two low profile 20 pins connectors with standard pin outs that can be used to directly manage the numerous **grifo®** cards; one **LCD 20x2 display** with adjustable backlighting; one 16 keys **matrix keyboard**; 2 push **buttons** and 2 **LEDs** suitable for setting, forcing and display the status of 2 TTL I/O lines; **pod** and jumper for **A/D reference voltage** connection; **two mounting possibilities**: layed on a plane surface through 4 rubber supports or bolt on each surfaces through 4 support holes, placed on the corner of the board; **small dimension**: 100 x 214 x 18 mm.

grifo®
ITALIAN TECHNOLOGY

Via dell' Artigiano, 8/6
40016 San Giorgio di Piano
(Bologna) ITALY
E-mail: grifo@grifo.it



<http://www.grifo.it> <http://www.grifo.com>
Tel. +39 051 892.052 (a. r.) FAX: +39 051 893.661

GMM TST

Rel. 5.00

Rel. 22 January 2003

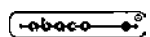
, GPC®, grifo®, are trade marks of grifo®

DOCUMENTATION COPYRIGHT BY grifo®, ALL RIGHTS RESERVED

No part of this document may be reproduced, transmitted, transcribed, stored in a retrieval system, or translated into any language or computer language, in any form or by any means, either electronic, mechanical, magnetic, optical, chemical, manual, or otherwise, without the prior written consent of **grifo®**.

IMPORTANT

Although all the information contained herein have been carefully verified, **grifo®** assumes no responsibility for errors that might appear in this document, or for damage to things or persons resulting from technical errors, omission and improper use of this manual and of the related software and hardware.

grifo® reserves the right to change the contents and form of this document, as well as the features and specification of its products at any time, without prior notice, to obtain always the best product.

For specific informations on the components mounted on the card, please refer to the Data Book of the builder or second sources.

SYMBOLS DESCRIPTION

In the manual could appear the following symbols:



Attention: Generic danger



Attention: High voltage

Trade Marks

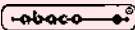
, **GPC®**, **grifo®** : are trade marks of **grifo®**.

Other Product and Company names listed, are trade marks of their respective companies.

GENERAL INDEX

INTRODUCTION	1
CARD VERSION	1
GENERAL FEATURES	2
TECHNICAL FEATURES	4
GENERAL FEATURES	4
PHYSICAL FEATURES	4
ELECTRIC FEATURES	4
INSTALLATION	6
CONNECTIONS	6
CN1 - POWER SUPPLY CONNECTOR	6
CN5 - RS 232 SERIAL LINE CONNECTOR	7
CN3 - TTL I/O CONNECTOR FOR PORT 0 AND 2	8
CN4 - TTL I/O CONNECTOR FOR PORT 1, P3.2÷7 AND P4.0÷1	10
RESET KEY	12
I/O CONNECTION	12
BUZZER	12
COLOURED BUTTONS	13
LCD DISPLAY AND KEYBOARD	13
VISUAL FEEDBACK	13
JUMPERS	14
SOFTWARE DESCRIPTION	16
LCD DISPLAY 20X2 WITH BACKLIGHTING	16
MATRIX KEYBOARD 4X4	16
AUTO-OSCILLATING BUZZER	16
LEDS AND BUTTONS	16
ELECTRIC DIAGRAM	16
APPENDIX A: DATA SHEET OF 20X2 DISPLAY	A-1
APPENDIX B: ALPHABETICAL INDEX	B-1

FIGURE INDEX

FIGURE 1: CARD PHOTO	3
FIGURE 2: CARD OVERALL IMAGE	5
FIGURE 3: CN1 - POWER SUPPLY CONNECTOR	6
FIGURE 4: CN5 - RS 232 SERIAL LINE CONNECTOR	7
FIGURE 5: CN3 - TTL I/O CONNECTOR FOR PORT 0 AND 2	8
FIGURE 6: CORRESPONDANCE BETWEEN PINS OF Z1 OR Z2 AND MINI MODULES SIGNALS ON CN3 ...	9
FIGURE 7: CN4 - TTL I/O CONNECTOR FOR PORT 1, P2.3÷7 AND P4.0÷1	10
FIGURE 8: CORRESPONDANCE BETWEEN PINS OF Z2 AND MINI MODULES SIGNALS ON CN4	11
FIGURE 9: VISUAL FEEDBACK TABLE	13
FIGURE 10: JUMPERS SUMMARIZING TABLE	14
FIGURE 11: JUMPERS, CONNECTORS, LEDs, BUTTONS, ETC. LOCATION	15
FIGURE 12: CONNECTION BETWEEN MINI MODULES AND SOME PINS OF Z1	17
FIGURE 13: GMM TST ELECTRIC DIAGRAM (PART 1)	18
FIGURE 14: GMM TST ELECTRIC DIAGRAM (PART 2)	19

INTRODUCTION

The use of these devices has turned - IN EXCLUSIVE WAY - to specialized personnel.

The purpose of this handbook is to give the necessary information to the cognizant and sure use of the products. They are the result of a continual and systematic elaboration of data and technical tests saved and validated from the manufacturer, related to the inside modes of certainty and quality of the information.

The reported data are destined- IN EXCLUSIVE WAY- to specialized users, that can interact with the devices in safety conditions for the persons, for the machine and for the environment, impersonating an elementary diagnostic of breakdowns and of malfunction conditions by performing simple functional verify operations , in the height respect of the actual safety and health norms.

The informations for the installation, the assemblage, the dismantlement, the handling, the adjustment, the reparation and the contingent accessories, devices etc. installation are destined - and then executable - always and in exclusive way from specialized warned and educated personnel, or directly from the TECHNICAL AUTHORIZED ASSISTANCE, in the height respect of the manufacturer recommendations and the actual safety and health norms.

The devices can't be used outside a box. The user must always insert the cards in a container that respect the actual safety normative. The protection of this container is not threshold to the only atmospheric agents, but specially to mechanic, electric, magnetic, etc. ones.

To be on good terms with the products, is necessary guarantee legibility and conservation of the manual, also for future references. In case of deterioration or more easily for technical updates, consult the AUTHORIZED TECHNICAL ASSISTANCE directly.

To prevent problems during card utilization, it is a good practice to read carefully all the informations of this manual. After this reading, the user can use the general index and the alphabetical index, respectly at the begining and at the end of the manual, to find information in a faster and more easy way.

CARD VERSION

The present handbook is reported to the **GMM TST** card release **211002** and later. The validity of the bring informations is subordinate to the number of the card release. The user must always verify the correct correspondence among the two denotations. On the card the release number is present in more points both board printed diagram (serigraph) and printed circuit (for example in the coreof the card both on the component side and on the solder side).

GENERAL FEATURES

GMM TST (grifo® MiniModule Test) is an experimental board based on **grifo®** Mini Modules featuring two 40 pins socket compatible with **GMM 5115**, **GMM AC2**, **CAN GM1**, **GM2**, etc. (**grifo®** MiniModule based on **T89c5115** and **T89c51AC2** - Controller Area Network - **grifo®** MiniModule 1, 2, etc.).

It is provided with specific hardware to interface all I/O signals of Mini Modules, in order to specialize the board for one's application.

Remarkable is the presence of an LCD display featuring 2 rows of 20 characters and adjustable backlight and a 16 keys matrix keyboard, that make extremely easy the development of any kind of applications oriented to the user interface, ranging from a simple terminal emulator to a smart programmable interface.

The presence of 2 coloured **LEDs** and 2 corresponding coloured push **buttons** connected to as many TTL I/O signals of microcontroller allows the application to be built faster, in fact they let the developer probe very quickly the program internal status during debugging, detect error conditions or particular situations, etc. An autoscillating **buzzer** is connected to another I/O signal of the microcontroller.

In addition, the board can support a **RS 232** serial interface, to test the communication modalities of application program.

A wide range of demo programs and use examples allow an immediate use of the board.

Overall features are:

- Two 40 pins dual in line female socket (100 mils pitch, 600 mils width) capable to accomodate 28 pins or 40 pins **grifo®** Mini Modules type **GMM AC2**, **GMM 5115**, **CAN GM1**, **CAN GM2**, etc. - Standard jack 2,1 mm power supply connector
- Power supply section that accept an input voltage in the range **7÷12V AC or DC**, compatible with the greater part of low cost main adaptors
- **LED** on +5 Vdc voltage, generated by power supply section
- **RESET** push button
- **Buzzer** for acoustic signal driven by Mini Module
- DB9 female connector with **RS 232** serial line
- Up to **32 TTL I/O lines** of Mini Module are connected to two low profile 20 pins connectors with standard pin outs that can be used to directly manage the numerous **grifo®** cards
- One **LCD 20x2 display** with adjustable backlighting
- One 16 keys **matrix keyboard**
- 2 push **buttons** and 2 **LEDs** suitable for setting, forcing and display the status of 2 TTL I/O lines
- **Pod** and jumper for **A/D reference voltage** connection
- **Two mounting possibilities**: layed on a plane surface through 4 rubber supports or bolt on each surfaces through 4 support holes, placed on the corner of the board
- **Small dimension**: 100 x 214 x 18 mm.

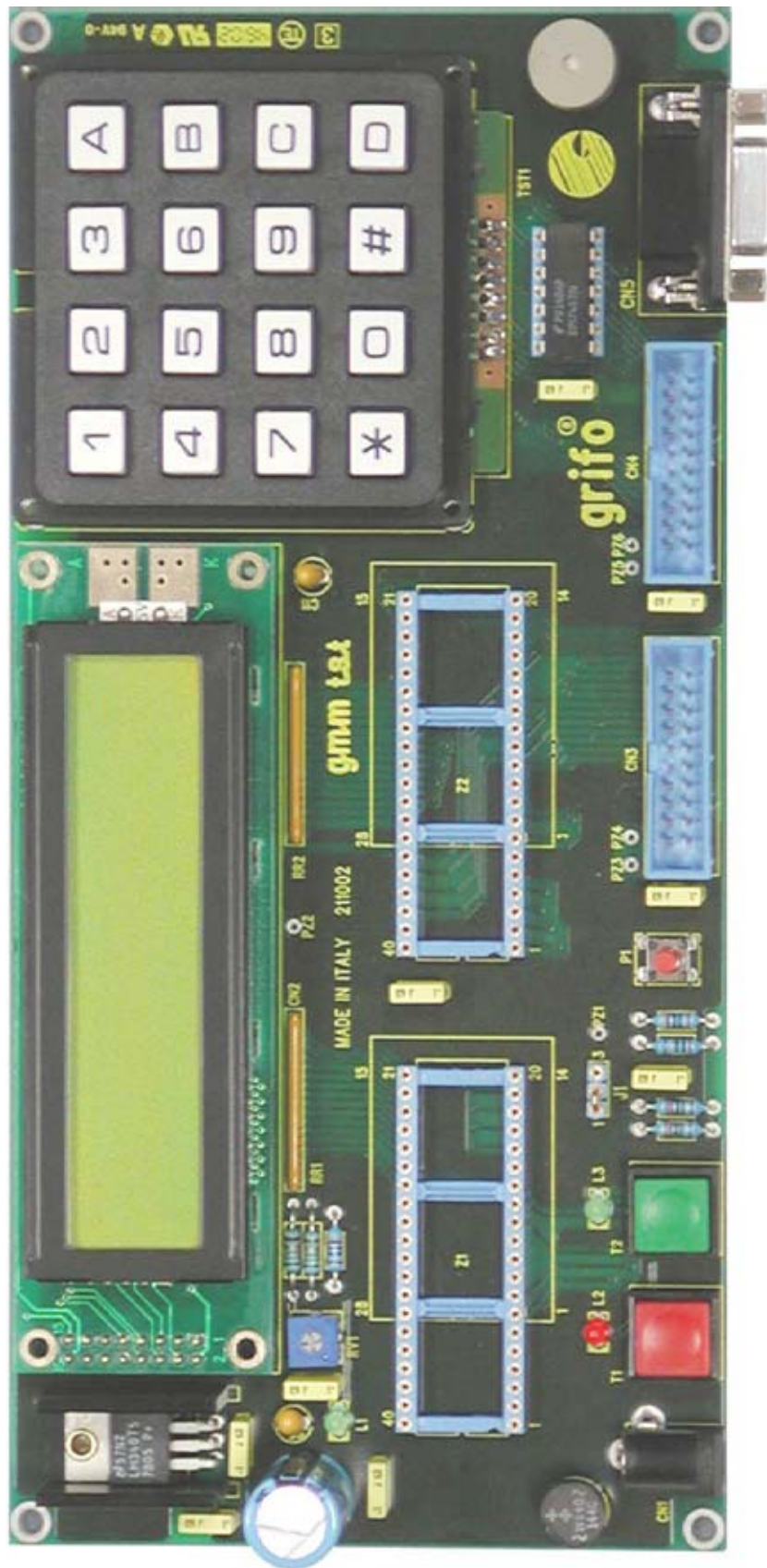

FIGURE 1: CARD PHOTO

TECHNICAL FEATURES

GENERAL FEATURES

Devices:

- 1 LCD 20x2 display with adjustable backlighting
- 2 matrix keyboard 4x4 featuring 16 keys
- 2 coloured push buttons
- 2 coloured LEDs
- 1 configuration jumpers for Vref
- 1 buzzer
- 1 reset key
- 1 power supply section based on 7805
- 2 female socket 40 pin for **grifo**[®] Mini Modules like **GMM 5115, GMM AC2, CAN GM1, CAN GM2**, ecc.

CPU: according to which **grifo**[®] Mini Module is installed

PHYSICAL FEATURES

Size: 100 x 214 x 18 mm

Weight: 200 g

Connectors:

- Z1: 40-pins female DIL socket for LCD and keyboard
- Z2: 40-pins female DIL socket for low profile connector
- CN1: PCB mounting socket
- CN2: 16 pins soldered to the display
- CN3: 20 pins, male, vertical, low profile connector
- CN4: 20 pins, male, vertical, low profile connector
- CN5: 9 pins D type 90 degrees male

Temperature range: 0÷50 °C

Relative humidity: 20% ÷ 90% (without condense)

ELECTRIC FEATURES

Power supply voltage: 7÷12 Vac or 9÷16 Vdc (*)

Current available on +5 Vdc 400 ma (*)

(*) Data reported are referred to a working temperature of 20° C.

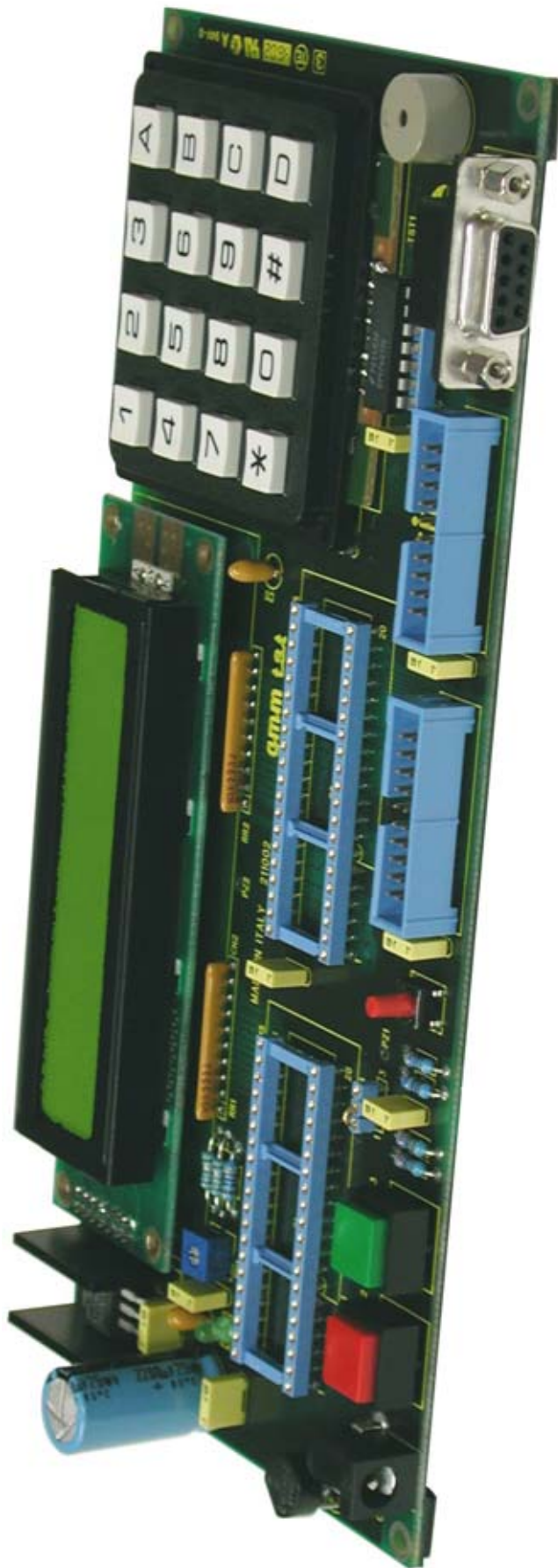

FIGURE 2: CARD OVERALL IMAGE

INSTALLATION

In this chapter there are the information for a right installation and correct use of the card. The user can find the location and functions of each connectors, jumpers, LEDs and some explanatory diagrams.

CONNECTIONS

The **GMM TST** module has 4 connectors that can be linkeded to other devices or directly to the field, according to system requirements. In this paragraph there are connectors pin out, a short signals description (including the signals direction) and connectors location (please refer to figure 11).

CN1 - POWER SUPPLY CONNECTOR

CN1 is a PCB mounting socket. The board supply voltage must be provided through this connector. Voltage in the range 7÷12 AC or 9÷16 DC, can be used; this means that any kind of inexpensive supply source (like cheap power supplies, transformers, etc.) can be employed to supply **GMM TST**.

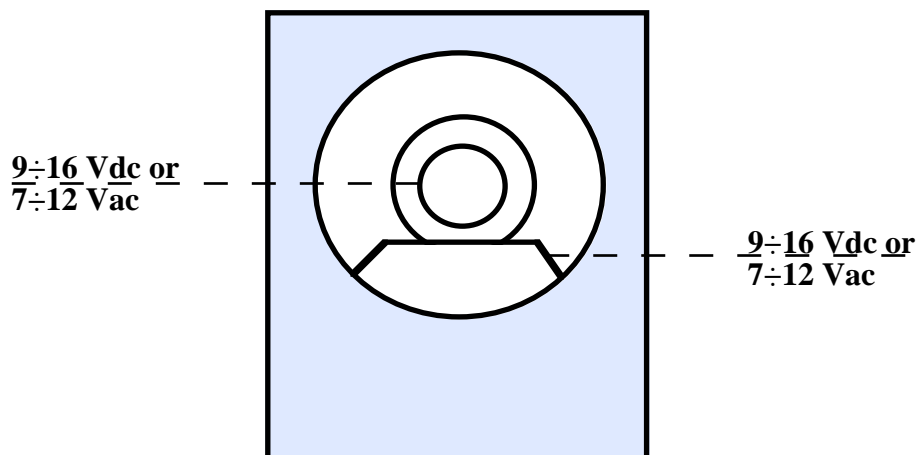

FIGURE 3: CN1 - POWER SUPPLY CONNECTOR

Signals description:

7÷12 Vac or 9÷16 Vdc = I - Input for power supply in the range 7÷12 V AC or 9÷16 DC

CN5 - RS 232 SERIAL LINE CONNECTOR

CN5 is a 9 pins, female, D type connector, 90 degrees.

This connector is dedicated to RS 232 connection.

The electric protocol follows the CCITT normative and all the signals are placed in order to reduce interference and electrical noise and in order to simplify connection with other systems.

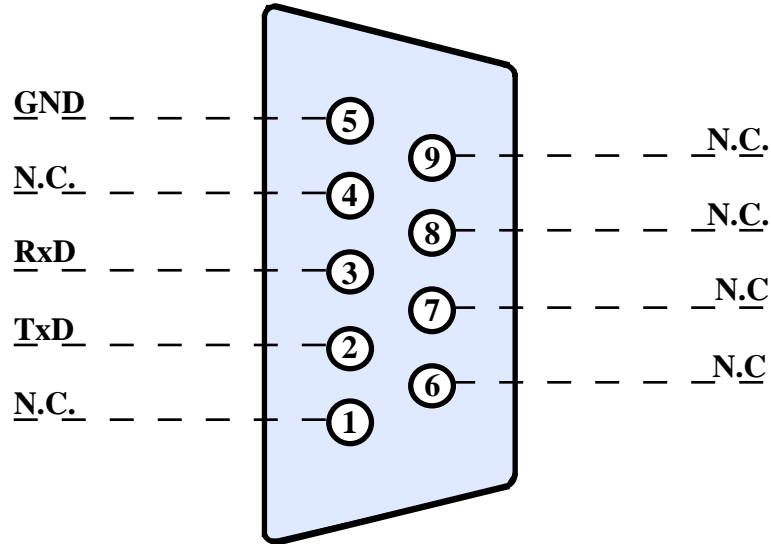

FIGURE 4: CN5 - RS 232 SERIAL LINE CONNECTOR

Signals description:

- RxD** = I - Serial line RS 232 Receive Data.
- TxD** = O - Serial line RS 232 Transmit Data.
- GND** = - Ground signal.
- N.C.** = - Not connected.

CN3 - TTL I/O CONNECTOR FOR PORT 0 AND 2

CN3 is a 20 pins, male, vertical, low profile connector, 2.54 mm pitch. Through CN3 the Mini Module on board signals and the external world are connected.

As the signals may vary according to the Mini Module installed, the following figure shows the socket pin number connected to the connector pin number. The table in the following page describes the signal physically connected to CN3 according to the Mini Module installed.

There is also the correspondance to **I/O ABACO®** standard connector used on **grifo®** cards.

Signals layout has been designed to reduce noise and interference and so to warrant a good connection performance.

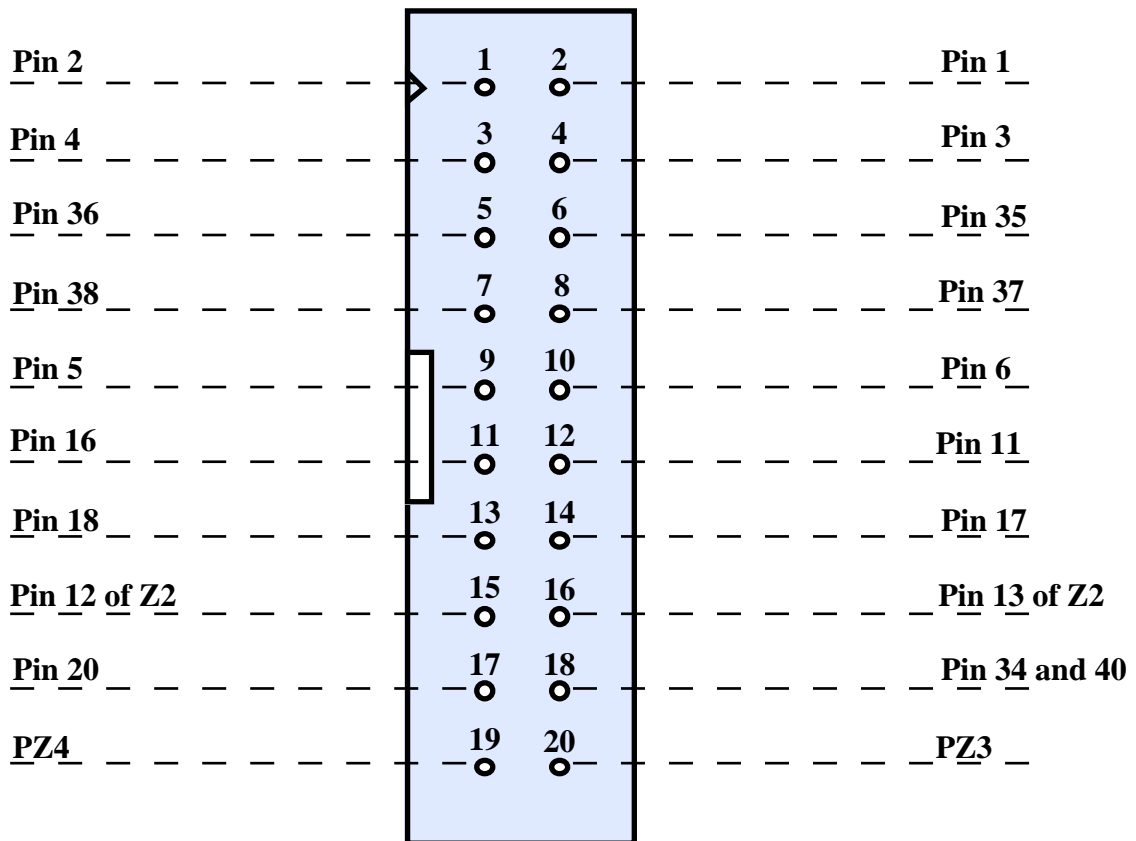

FIGURE 5: CN3 - TTL I/O CONNECTOR FOR PORT 0 AND 2

Signals description:

Correspondance between pins of Mini Module installed on Z1 or Z2 and signals available on CN3 is shown in following table.

PIN Z1 or Z2	I/O ABACO®	GMM 5115	GMM AC2	CAN GM1	CAN GM2
1	PA.0	-	P0.0	-	-
2	PA.1	-	P0.1	-	-
3	PA.2	-	P0.2	-	-
4	PA.3	-	P0.3	-	-
5	PC.6	-	P2.6	-	-
6	PC.7	-	P2.7	-	-
11	PC.5	DSW1.6	P2.5	/INT	/INT
12 (Z2)	PC.0	P2.0	P2.0	SCL	SCL
13 (Z2)	PC.1	P2.1	P2.1	SDA	SDA
16	PC.4	DSW1.7	P2.4	P2.4	DSW1.7
17	PC.3	Common DSW1.6, DSW1.7 and DSW1.8	P2.3	P2.3	Common DSW1.7 and DSW1.8
18	PC.2	DSW1.8	P2.2	P2.2	DSW1.8
20	N.C.	Gnd	Gnd	Gnd	Gnd
34	+5 Vdc	+5 Vdc	+5 Vdc	+5 Vdc	+5 Vdc
35	PA.4	-	P0.4	-	-
36	PA.5	-	P0.5	-	-
37	PA.6	-	P0.6	-	-
38	PA.7	-	P0.7	-	-
40	+5 Vdc	-	+5 Vdc	-	-

FIGURE 6: CORRESPONDANCE BETWEEN PINS OF Z1 OR Z2 AND MINI MODULES SIGNALS ON CN3

CN4 - TTL I/O CONNECTOR FOR PORT 1, P3.2÷7 AND P4.0÷1

CN4 is a 20 pins, male, vertical, low profile connector, 2.54 mm pitch. Through CN4 the Mini Module on board signals and the external world are connected.

As the signals may vary according to the Mini Module installed, the following figure shows the socket pin number connected to the connector pin number. The table in the following page describes the signal physically connected to CN4 according to the Mini Module installed.

There is also the correspondance to **I/O ABACO®** standard connector used on **grifo®** cards.

Signals layout has been designed to reduce noise and interference and so to warrant a good connection performance.

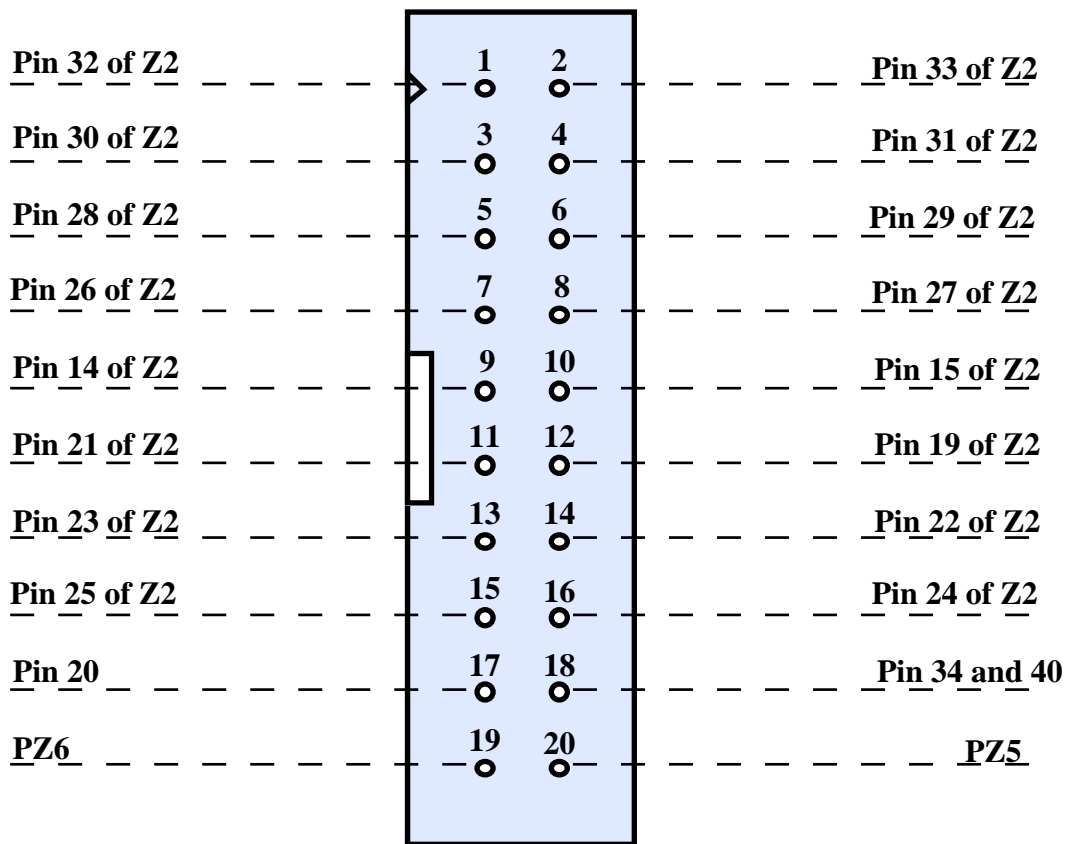

FIGURE 7: CN4 - TTL I/O CONNECTOR FOR PORT 1, P2.3÷7 AND P4.0÷1

Signals description:

Correspondance between pins of Mini Module installed on Z1 or Z2 and signals available on CN4 is shown in following table.

PIN Z2	I/O ABACO®	GMM 5115	GMM AC2	CAN GM1	CAN GM2
14	PC.6	P4.0	P4.0	CAN Low	CAN Low
15	PC.7	P4.1	P4.1	CAN High	CAN High
19	PC.5	P3.7	P3.7	P3.7	P3.7
21	PC.4	P3.6	P3.6	P3.6	P3.6
22	PC.3	P3.5	P3.5	P3.5	P3.5
23	PC.2	P3.4	P3.4	P3.4	P3.4
24	PC.1	P3.3	P3.3	P3.3	P3.3
25	PC.0	P3.2	P3.2	P3.2	P3.2
26	PA.7	P1.7	P1.7	P1.7	P1.7
27	PA.6	P1.6	P1.6	P1.6	P1.6
28	PA.5	P1.5	P1.5	P1.5	P1.5
29	PA.4	P1.4	P1.4	P1.4	P1.4
30	PA.3	P1.3	P1.3	P1.3	P1.3
31	PA.2	P1.2	P1.2	P1.2	P1.2
32	PA.1	P1.1	P1.1	P1.1	P1.1
33	PA.0	P1.0	P1.0	P1.0	P1.0

FIGURE 8: CORRESPONDANCE BETWEEN PINS OF Z2 AND MINI MODULES SIGNALS ON CN4

POWER SUPPLY

GMM TST board is provided with an efficient circuitry that allows to solve in an efficient and comfortable way the problem to supply the board in any use condition.

This section is based on the famous and efficient 7805 that allows to supply the board with a voltage in the range 7÷12 Volt, both AC and DC, without any polarity distinction through the PCB mounting socket CN1. The presence of a diode rectifier between CN1 and 7805 creates a voltage difference of about 0.6 Volts between the ground of an eventual DC supply input and the +5 Vdc of **GMM TST**.

RESET KEY

P1 reset key of **GMM TST** board allows the user to reset the Mini Module and restarting it in a general clearing condition.

The main purpose of this key is to come out of infinite loop conditions, useful especially during debug and develop phases, or to ensure a particular initial status. Please see figure 11 for an easy localization of this contact.

I/O CONNECTION

To prevent possible connecting problems between **GMM TST** and the external systems, the user has to read carefully the information of the previous paragraphs and he must follow these instructions:

- For RS 232 and CAN communication signals the user must follow the standard rules of these protocols.
- For all TTL signals the user must follow the rules of this electric standard. The connected digital signal must be always referred to card digital ground (GND). For TTL signals, the 0 Vdc level corresponds to logic state "0", while 5Vdc level corresponds to logic state "1".

BUZZER

An autoscillatin capacitive buzzer is installed on **GMM TST**, it generates a continuous sound at about 1 KHz by simply driving it with a Mini Module TTL signal.

Connection is made on pin 15 of Z1 (please see specific paragraph to know which microcontroller pin is connected).

COLOURED BUTTONS

GMM TST is provided with 6 buttons differentiated by their colour and connected to 6 corresponding LEDs with the same colour.

The purpose of this section is, for example, to set particular starting or working conditions of the application program, in addition to being able to perform demonstrations and analysis of any application system.

LCD DISPLAY AND KEYBOARD

GMM TST is provided with an LCD display featuring 2 rows of 20 characters and adjustable backlighting and a matrix keyboard with 4 rows by 4 columns featuring 16 keys.

Backlighting can be adjusted using trimmer RV1.

The two devices are totally independent and are driven through I/O TTL signals of Mini Module installed on socket Z1.

These devices allow to develop user interface applications much easier and more quickly.

For further information please read the chapter “SOFTWARE DESCRIPTION”.

VISUAL FEEDBACK

GMM TST board is provided with three LEDs:

LED	MEANING
L1	If ON, indicates the presence of +5 Vdc stabilized voltage.
L2	If ON, indicates that signal on pin 12 of Z1 is at low level (zero volt) or that button T1 is pressed.
L3	If ON, indicates that signal on pin 13 of Z1 is at low level (zero volt) or that button T2 is pressed.

FIGURE 9: VISUAL FEEDBACK TABLE

The main purpose of these LEDs is to give a visual indication of the Mini Module status, making easier the operations of system working verify. To easily locate these LEDs on the board, please refer to figure 11.

JUMPERS

GMMTST features 1 jumper that allows to perform configurations of the board working modalities. It allows to select the source for Mini Module A/D converter reference voltage (Vref). Here follows a more detailed description.

JUMPER	CONNECTION	PURPOSE	DEF.
J1	position 1-2	Connects pin 7 of Z1 and Z2 to +2.5 Vdc constant stabilized voltage.	*
	position 2-3	Connects pin 7 of Z1 and Z2 to pod PZ1.	

FIGURE 10: JUMPERS SUMMARIZING TABLE

The * means default connection.

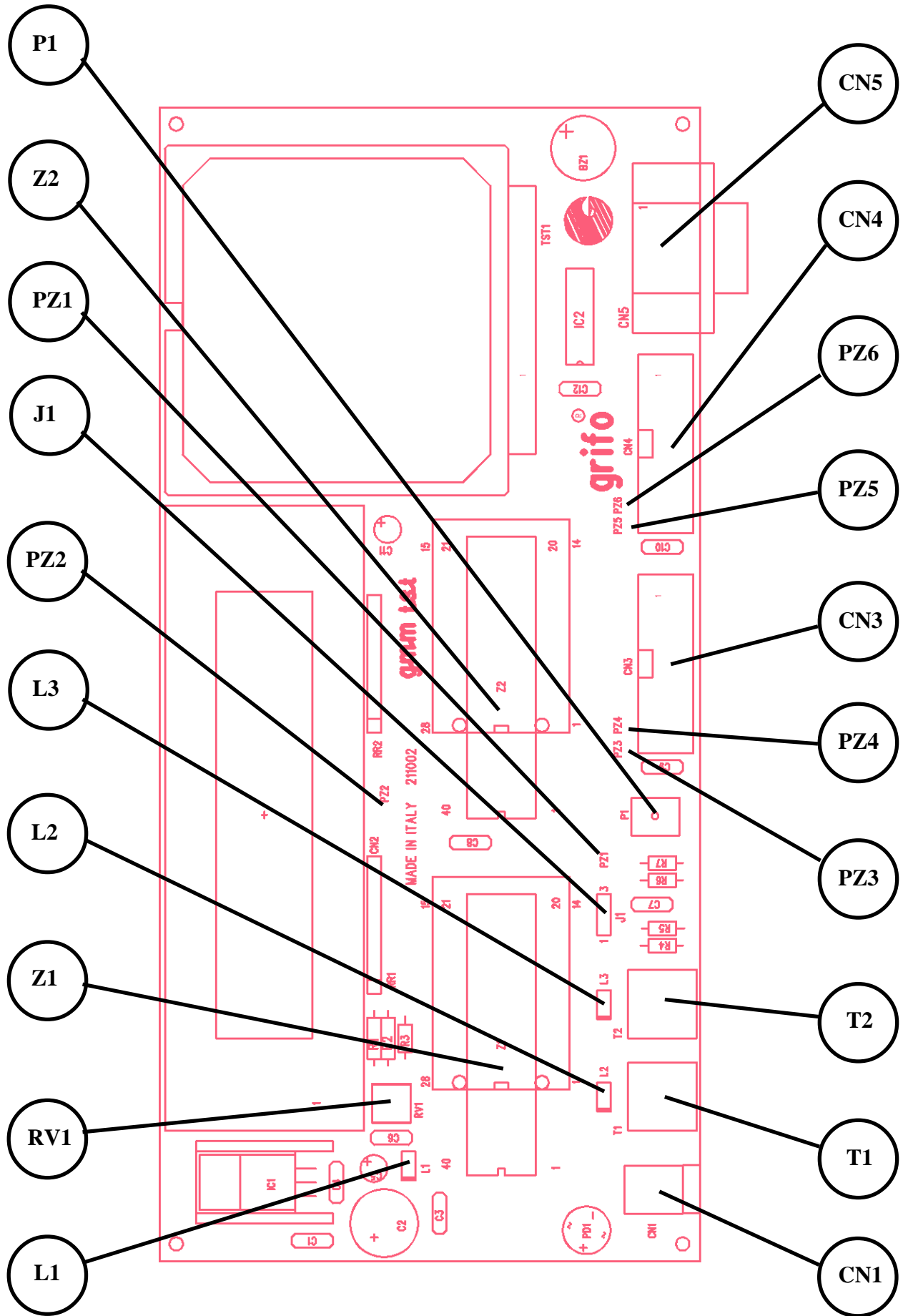

FIGURE 11: JUMPERS, CONNECTORS, LEDs, BUTTONS, ETC. LOCATION

SOFTWARE DESCRIPTION

The following devices can be accessed through the TTL I/O signals of socket Z1 only. This means that they are completely independent from the connections made on socket Z2. In addition they are independent each other.

Some Mini Modules may not allow to use the above mentioned devices.

LCD DISPLAY 20X2 WITH BACKLIGHTING

The display installed on **GMM TST** is a **SDEC LMC-SSC2A20** or compatible.

Please refer to the electric diagram for more information about the connection of display and socket Z1 and refer to table of figure 12 to know which TTL I/O signals are to be used according to the Mini Module installed.

For further information about the display working mode please refer to the data sheet in appendix A of this manual.

MATRIX KEYBOARD 4X4

Keyboard installed on **GMM TST** features 4 columns each one connected to 4 rows that make a total of 16 keys.

Please refer to the electric diagram for more information about the connection of keyboard and socket Z1 and refer to table of figure 12 to know which TTL I/O signals are to be used according to the Mini Module installed.

AUTO-OSCILLATING BUZZER

GMM TST features an auto-oscillating buzzer that can be driven simply by a TTL I/O signal of Mini Module installed on socket Z1. It is enough to set the corresponding signal to 0 (set bit to 0) to activate the buzzer and to set to 1 (set bit to 1) to deactivate it.

Please refer to the electric diagram for more information about the connection of buzzer and socket Z1 and refer to table of figure 12 to know which TTL I/O signals are to be used according to the Mini Module installed.

LEDS AND BUTTONS

GMM TST features two LEDs, called L2 and L3, red and green, that can be driven through I/O TTL signals of Mini Module installed on socket Z1. Each LED is connected to a push button, respectively T1 and T2, to turn on a LED it is enough to set to 0 the corresponding signal (set bit to 0) or press the corresponding button while to turn it off it is enough to set the signal to 1 and release the button. Push button status is readable through a read operation from the bit that drives the corresponding LED; in detail when button is pressed the signal results low (bit is equal to 0), viceversa if the button is released the signal will be high (bit is equal to 1).

Please refer to the electric diagram for information about the connection of LEDs and button and socket Z1 and to figure 12 to know the TTL I/O signals to use according to the Mini Module installed.

Socket Z1	GMM 5115	GMM AC2	CAN GM1	CAN GM2
12	P2.0	P2.0	P2.0	P2.0
13	P2.1	P2.1	P2.1	P2.1
14	P4.0	P4.0	CAN Low	CAN Low
15	P4.1	P4.1	CAN High	CAN High
19	P3.7	P3.7	P3.7	P3.7
21	P3.6	P3.6	P3.6	P3.6
22	P3.5	P3.5	P3.5	P3.5
23	P3.4	P3.4	P3.4	P3.4
24	P3.3	P3.3	P3.3	P3.3
25	P3.2	P3.2	P3.2	P3.2
26	P1.7	P1.7	P1.7	P1.7
27	P1.6	P1.6	P1.6	P1.6
28	P1.5	P1.5	P1.5	P1.5
29	P1.4	P1.4	P1.4	P1.4
30	P1.3	P1.3	P1.3	P1.3
31	P1.2	P1.2	P1.2	P1.2
32	P1.1	P1.1	P1.1	P1.1
33	P1.0	P1.0	P1.0	P1.0

FIGURE 12: CONNECTION BETWEEN MINI MODULES AND SOME PINS OF Z1

ELECTRIC DIAGRAM

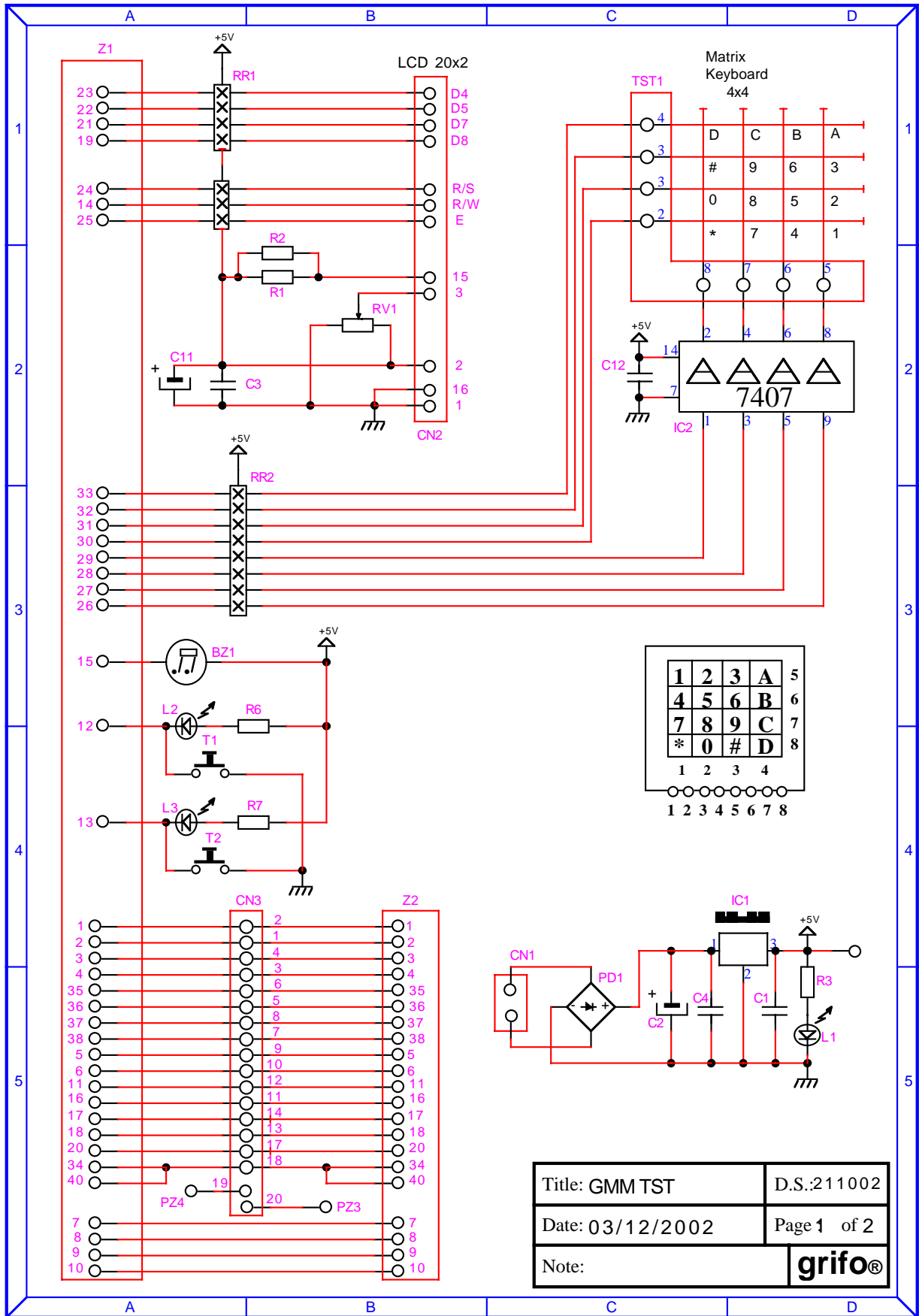

FIGURE 13: GMM TST ELECTRIC DIAGRAM (PART 1)



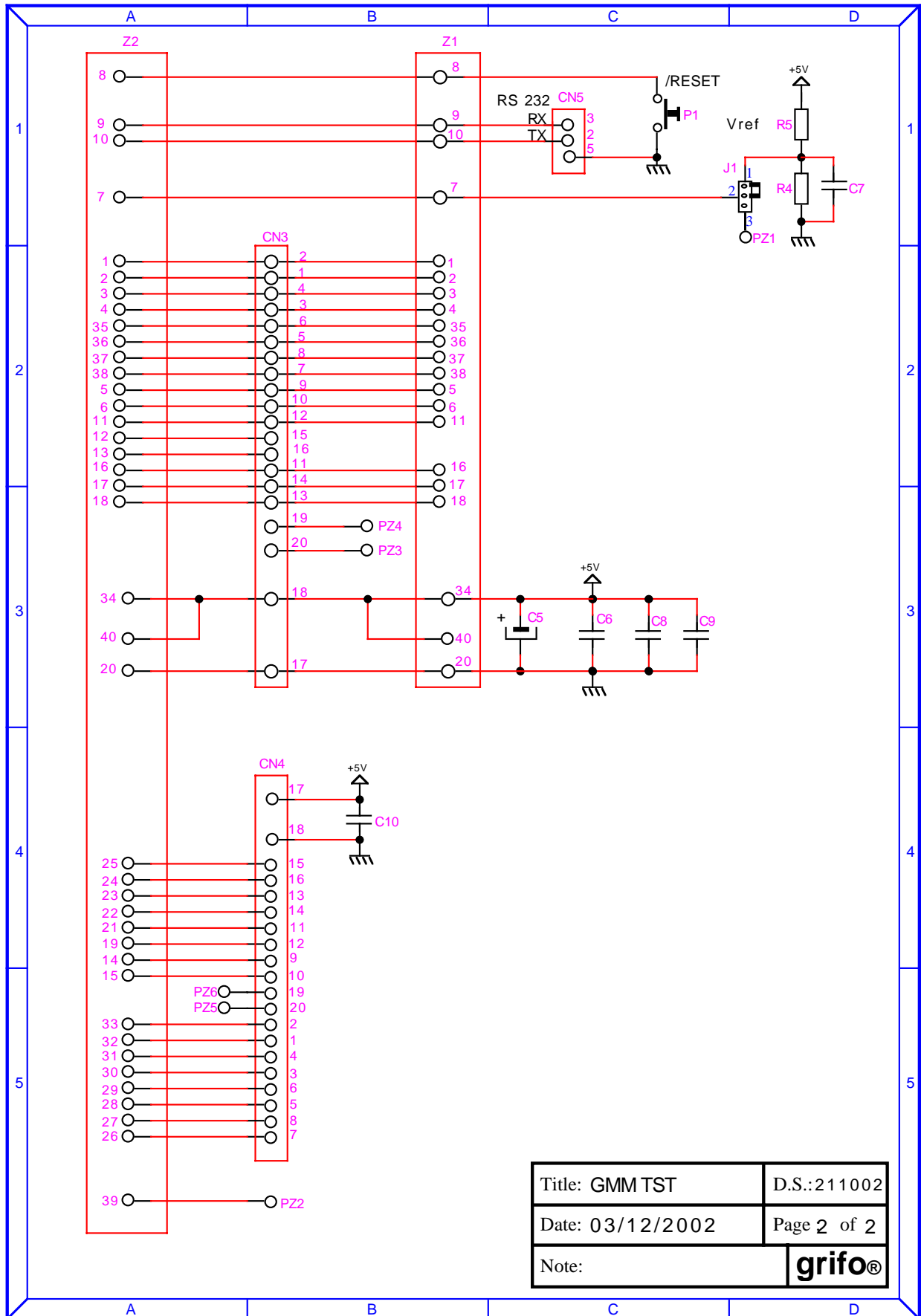

FIGURE 14: GMM TST ELECTRIC DIAGRAM (PART 2)



SDEC

DOT MATRIX LIQUID CRYSTAL DISPLAY MODULE

LMC-SSC2A20 Serial USER' MANUAL

LMC-SSC2A20DRG-01	LMC-SSC2A20DRY-01
LMC-SSC2A20DEGB-01	LMC-SSC2A20DEYW-01
LMC-SSC2A20DLGY-01	LMC-SSC2A20DLYY-01

PROPOSED BY		APPROVED
Design	Approved	

SDEC TECHNOLOGY CORP.

5. Absolute Maximum Ratings

ITEM	SYMBOL	MIN.	TYPE	MAX.	UNIT
OPERATING TEMPERATURE	TOP	0/-20	-	+50/+70	°C
STORAGE TEMPERATURE	TST	-10/+30	-	+60/+80	°C
INPUT VOLTAGE	VI	VSS	-	VDD	V
SUPPLY VOLTAGE FOR LOGIC	VDD-VSS	-	5.0	6.5	V
SUPPLY VOLTAGE FOR LCD	VDD-AVO	-	-	6.5	V
STATIC ELECTRICITY	Be sure that you are grounded when handling LCM.				

6. Electrical Characteristics

ITEM	SYN	CONDITION	MIN.	TYPE	MAX.	UNIT
SUPPLY VOLTAGE FOR LOGIC	VDD-VSS	-	4.5	5.0	5.5	V
SUPPLY VOLTAGE FOR LCD	VDD-AVO	Ta= 0/-20 °C Tb= 25°C Ta= +50/+70 °C	-	4.8/5.0 4.4 4.1/3.9	-	V
INPUT HIGH VOLTAGE	VIH	-	2.2	-	VDD	V
INPUT LOW VOLTAGE	VIL	-	0	-	0.6	V
OUTPUT HIGH VOLTAGE	VOH	-	2.4	-	-	V
OUTPUT LOW VOLTAGE	VOL	-	-	-	0.4	V
SUPPLY CURRENT	IDD	VDD=+5V	-	3.0	4.5	mA

7. Optical Characteristics

ITEM	SYM	CONDITION	MIN.	TYPE	MAX.	UNIT
VIEW ANGLE (V)	∠c	CR=∅	-10	-	40	deg.
VIEW ANGLE (H)	∠p	CR=∅	-30	-	30	deg.
CONTRAST RATIO	CR	-	-	5	-	-
RESPONSE TIME	TON	-	-	180	230	ms
RESPONSE TIME	TOFF	-	-	100	150	ms

8. Optical Definitions

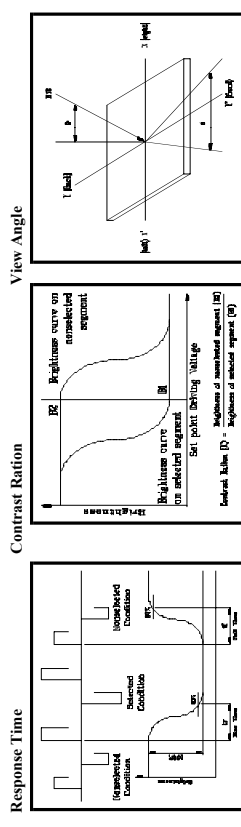

9. Display Address

Line 1	80	81	82	83	84	85	86	87	88	89	8A	8B	8C	8D	8E	8F	90	91	92	93
Line 2	C0	C1	C2	C3	C4	C5	C6	C7	C8	C9	CA	CB	CC	CD	CE	CF	D0	D1	D2	D3
Line 3																				
Line 4																				

1. Mechanical Specification

ITEM	STANDARD VALUE	UNIT
NUMBER OF CHARACTERS	20 CHARACTERS X 2 LINES	-
CHARACTER FORMAT	5 X 8 DOTS	-
MODULE DIMENSION	115.0 (W) X 36.0 (H) X 10.5 (D) 115.0 (W) X 36.0 (H) X 15.0 (T)	mm
VIEWING DISPLAY AREA	83.0 (W) X 18.6 (H)	mm
ACTIVE DISPLAY AREA	73.5 (W) X 11.5 (H)	mm
CHARACTER SIZE	3.20 (W) X 5.55 (H)	mm
CHARACTER PITCH	3.70 (W) X 5.95 (H)	mm
DOT SIZE	0.60 (W) X 0.65 (H)	mm
DOT PITCH	0.65 (W) X 0.70 (H)	mm
LMC-SSC2A20DRG-01	STN., Gray., 1/16 Duty., 6 O'clock	
LMC-SSC2A20DRY-01	STN., Yellow Green., 1/16 Duty., 6 O'clock	
LMC-SSC2A20DEGB-01	STN., Gray., 1/16 Duty., 6 O'clock, EL Backlight (color is Blue)	
LMC-SSC2A20DEWB-01	STN., Yellow Green., 1/16 Duty., 6 O'clock, EL Backlight (color is White)	
LMC-SSC2A20DGV-01	STN., Gray., 1/16 Duty., 6 O'clock, LED Backlight	
LMC-SSC2A20DXY-01	STN., Yellow Green., 1/16 Duty., 6 O'clock, LED Backlight	
EL Use Inverter Type	SPEC1002A	
Inverter Input	V	40 mA
Inverter Output	V	AC 90 ~ 700 Hz
Backlight Half-Lift Time	3,000	HR.
LED Backlight Color	Yellow Green	
Backlight Input	V	140 mA
Backlight Half-Lift Time	50,000	HR.

2. Mechanical Diagram

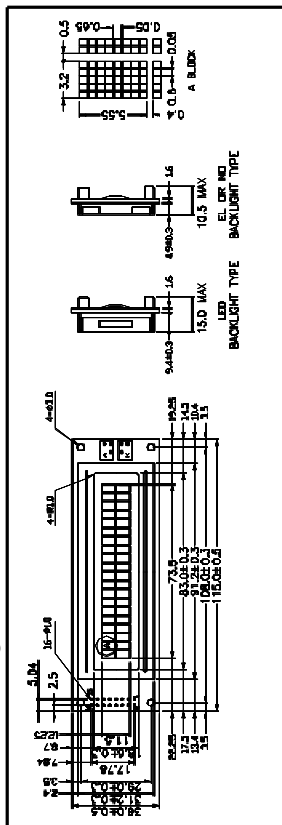

3. Interface Pin Connections

NO	SYMBOL	LEVEL	FUNCTION
1	VSS	-	GND (0V)
2	VDD	H/L	DC +5V
3	VO	H/L	Contrast Adjust
4	RS	H/L	Register select
5	R/W	H/L	Read/Write
6	E	H, H→L	Enable signal
7	DB0	H/L	Data Bit 0
8	DB1	H/L	Data Bit 1
9	DB2	H/L	Data Bit 2
10	DB3	H/L	Data Bit 3
11	DB4	H/L	Data Bit 4
12	DB5	H/L	Data Bit 5
13	DB6	H/L	Data Bit 6
14	DB7	H/L	Data Bit 7
15	A(+)	DC+5V	LED Backlight +
16	K(-)	0V	LED Backlight -

4. Block Diagram

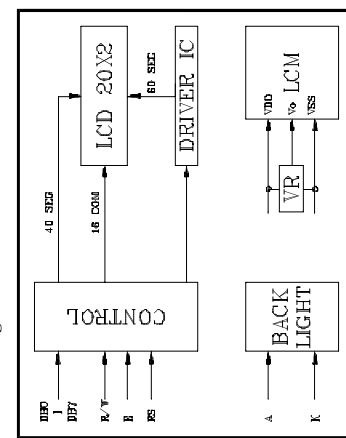

12. Initialization of LCM

The LCM automatically initializes (reset) when power is turned on using the internal reset circuit. If the power supply conditions for correctly operating of the internal reset circuit are not met, initialization by instruction is required. Use the procedure is next page for initialization.

Internal Power Supply reset

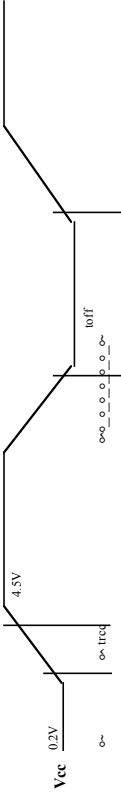

(Note 1) 10 ms *trf, *X0.1 ms , toff *Y1 ms.

(Note 2) toff stipulates the time of power OFF for momentary power supply dip or when power supply cycles ON and OFF.

Item	Symbol	Test condition	Limit (Min.)	Limit (Max.)	Unit
Power supply rise time	trcc	-	0.1	10	ms
Power supply off time	toff	-	-	-	ms

1) 8 Bit Interface

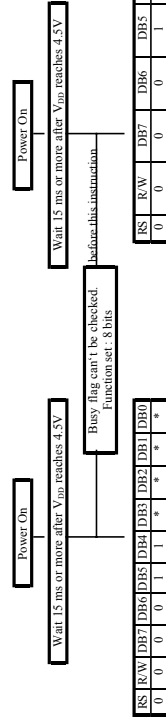

2) 4 Bit Interface

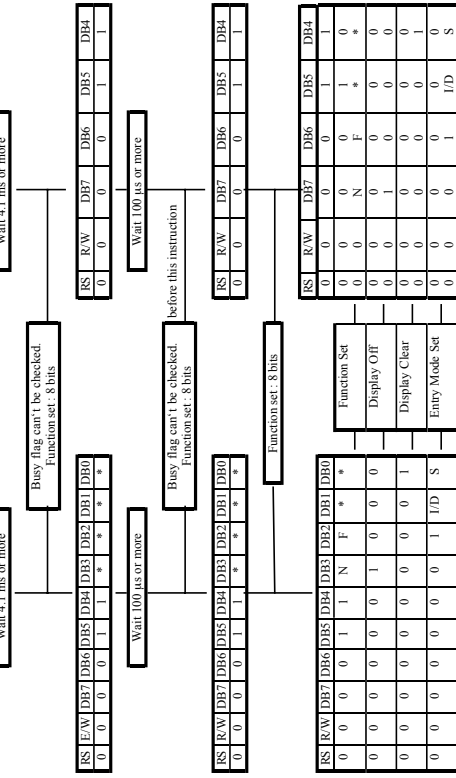

- Busy flag is checked after instructions are completed. If busy flag isn't checked, the waiting time between instructions should be longer than execution time of these instructions.

10. Interface to MPU

10.1 Interface to Z-80 CPU

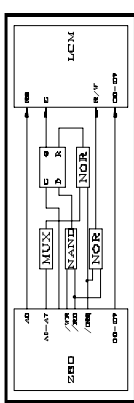

10.2 Interface to MC6800 CPU

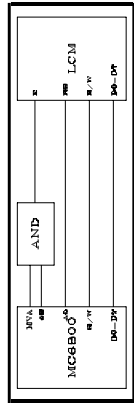

10.3 Interface to 4-bit CPU (HMC543C)

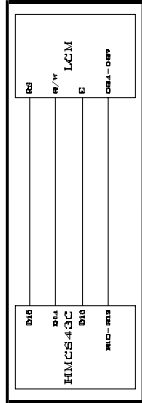

10.4 Interface to HD6805 MP

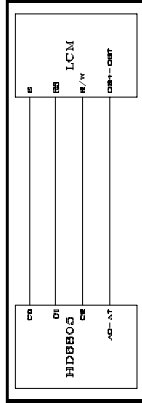

11. Timing Control

11.1 Write and Read Operation

Write Operation

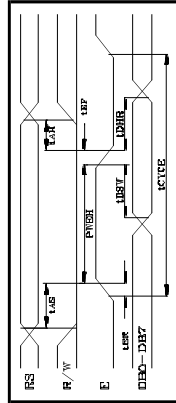

Read Operation

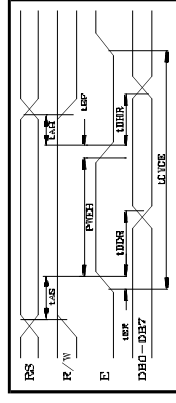

Item	Symbol	Limit (Min.)	Limit (Max.)	Unit
Enable Cycle Time	tCYCE	1000	-	ns
Enable Pulse Width (High level)	PWEH	450	-	ns
Enable Rise/Fall Time	tER, tEF	-	25	ns
Address Set-Up Time (RS,R/W,E)	tAS	100	-	ns
Address Hold Time	tAH	10	-	ns
Data Set-Up Time	tDSW	100	-	ns
Data Delay Time	tDDR	-	190	ns
Data Hold Time	tDHR	-	-	ns

11.2 Busy flag check timing

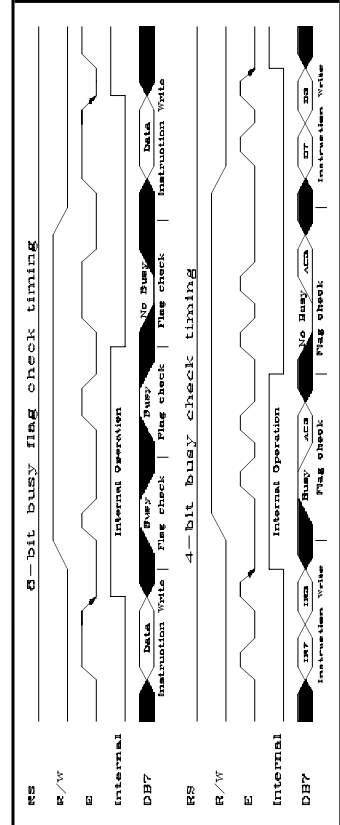

15. Software Example

15.1 8-bit operation (8 bits 2 lines)

Function	R	R	R	D	D	D	D	D	D	D	D	D	D	D	D	Display	Description
	S	w	7	6	5	4	3	2	1	0							
Power on delay	0	0	0	0	0	0	0	0	0	0	0	0	0	0	0		Initialization. No display appears.
Function set	0	0	0	0	1	1	0	0	x	x							Sets to 8-bit operation and selects 2-line display and 5x7 dots character font. (Note: number of display lines and character fonts cannot be changed after this.)
Display OFF	0	0	0	0	0	0	1	0	0	0							Turn off display.
Display ON	0	0	0	0	0	0	1	1	0	0							Turn on display and cursor
Entry Mode Set	0	0	0	0	0	0	0	0	1	1	0						Set mode to increment the address by one and to shift the cursor to the right, at the time of write, to the DD/CG RAM display.
Write data to CG/DDRAM	1	0	0	1	0	1	0	0	1	1	S						Write "S". Cursor incremented by one and shift to right.
Write data to CG/DDRAM	1	0	0	1	0	0	0	0	1	1	S						Write "D", "E", and "C".
Set DD RAM	0	0	1	1	0	0	0	0	0	0							Set RAM address so that the cursor is repositioned at the head of the second line.
Write data to CG/DDRAM	*																Write "C", and "R".
Cursor or display shift	0	0	0	0	1	0	0	x	x	S/DEC							Shift only the cursor position to the left.
Write data to CG/DDRAM	*																Write "O, L/TD,".
Entry Mode Set	0	0	0	0	0	1	1	1	S/DEC								Set display mode shift at the time during writing operation.
Write data to CG/DDRAM	1	0	0	1	1	1	0	0	0	0							Write "x". Cursor incremented by one and shift to right. (The display move to left.)
Write data to CG/DDRAM	*																Write other characters.
Return Home	0	0	0	0	0	0	0	0	1	0							Return both display and cursor to the original position (Set address to zero).

15.2 4-bit operation (4-bit, 1 line)

Function	RS/R	D7	D6	D5	D4	Display	Description
	W						
power on delay							Initialization. No display appears.
Function set	0	0	0	1	0		Sets to 4-bit operation. In this case, operation is handled as 8-bits by initialization, and only this instruction completes with one write.
Function set	0	0	0	0	1		Sets 4-bit operation and selects 1-line display and 5x7 dot character font on and resetting is needed. (number of display lines and character fonts cannot be changed hence after.)
Display ON/OFF Control	0	0	0	0	0		Turn on display and cursor.
Entry Mode Set	0	0	0	1	0		Set mode to increment the address by one and to shift the cursor to the right, at the time of write, to the DD/CG RAM display.
Write data to CG/DDRAM	1	0	0	1	0	1	Write "S". Cursor incremented by one and shift to right.
Return Home	1	0	0	0	1	1	Write "S". Cursor incremented by one and shift to right.

same as 8-bit operation

PAGE 7 (LMC-SSC2A20-01 Serial)

16. Reliability Condition

PAGE 5 (LMC-SSC2A20-01 Serial)

13. Instruction Set

FUNCTION	R	R	R	D	D	D	D	D	D	D	D	D	D	D	D	EXECU. TIME* (MAX.)
	S	w	7	6	5	4	3	2	1	0						
Clear Display	0	0	0	0	0	0	0	0	0	1	x					1.64ms
Return Home	0	0	0	0	0	0	0	0	0	1	x					1.64ms
Entry mode set	0	0	0	0	0	0	1	/	S							40eg
Display ON/OFF control	0	0	0	0	0	1	D	C	B							40eg
Cursor or Display shift	0	0	0	0	1	/	/	x	S	R						40eg
Function Set	0	0	0	0	1	D	N	F	x	L						40eg
Set CG RAM address	0	0	0	1	ACG											40eg
Set DD RAM address	0	0	1	ADD												40eg
Read busy flag & address	0	1	B	AC												1 eg
Write Data to CG/DDRAM	1	0	WRITE DATA													40eg
Read Data for CG/DDRAM	1	1	READ DATA													40eg

14. User Font Patterns (CG RAM Character)

Character Code (DD RAM data)	CG RAM Address	Character Pattern (CG RAM data)
H: 7,6,5,4,3,2,1,0	5,4,3,2,1,0	H: 7,6,5,4,3,2,1,0
0000x000	000 001 010 000 011 100 101 110 111	xxx 111110 xxx 10001 xxx 10001 xxx 11110 xxx 10100 xxx 10010 xxx 10001 xxx 00000
0000x001	000 001 010 000 1 100 101 110 111	xxx 10001 xxx 10110 xxx 11110 xxx 11111 xxx 00110 xxx 00100 xxx 00000
0000x111	000 001 010 111 011 100 101 110 111	----- 000 001 010 111 011 100 101 110 111

PAGE 6 (LMC-SSC2A20-01 Serial)



17.5 Minor Defect

Except the Major defects above, all cosmetic defects are classified as minor defects.

Item No.	Item to be Inspected	Inspection Standard			Classification of defects	
		Zone size (mm)	Acceptable Qty			
1.	Spot defect (Defects in spot from)	£X0.5	A	B	Minor	
			Acceptable (clutering of spot not allowed)			
			1	2		
			0	1		
Remarks : for dark/white spot, size £X defined as £X1/2(X+Y)						
2.	Line defect (Defects in line form)	L	Acceptable Qty		Minor	
			Length	Zone		
				A		B
			W	Acceptable		
				table		
			L>2.5	0		
2						
Remarks: The total of spot defect and line defect shall not exceed four.						
3.	Orientation defect (such as misalignment of L/C)	Not allowed inside viewing area (Zone A or Zone B)			Minor	
4.	Polarizing	17.5.4.1 Polarizer Position			Minor	
		1. Shifting in Position Should not exceed the glass outline dimension.				
		2. Incomplete covering of the viewing area due to Shifting is not allowed.				
		17.5.4.2 Scratches, bubble or dent on Glass/ Polarizer/Reflector, Bubble between Polarizer & Reflector/Glass:				
Size (mm)		Acceptable Qty				
		Zone				
		A	B	C		
£X0.20		Acceptable		Acceptable		
0.20<£X0.50		3		table		
0.50<£X1.00		2				
£X1.00		0				

Viewing Angle	Horizontal £X	Vertical £X	TN Type		STN Type	
			Normal Temp.	Wide Temp.	Normal Temp.	Wide Temp.
Operating Temperature	30±X	30±X	30±X	30±X	30±X	30±X
	10±X	30±X	-10±X	40±X	-10±X	40±X
Storage Temperature (Power Off)	-10 to 70±J	-25 to 80±J	0 to 50±J	*-20 to 70±J	*-30 to 80±J	240 Hours
	-20 to 80±J	-35 to 90±J	240 Hours	@-65±J	@-75±J	240 Hours
Low Temperature (Power Off)	240 Hours	240 Hours	240 Hours	240 Hours	240 Hours	240 Hours
	@-20±J	@-35±J	@-15±J	@-25±J	@-25±J	240 Hours
High Temperature (Power On)	240 Hours	240 Hours	240 Hours	240 Hours	240 Hours	240 Hours
	@-70±J	@-80±J	@-60±J	@-70±J	@-70±J	240 Hours
Low Temperature (Power On)	240 Hours	240 Hours	240 Hours	240 Hours	240 Hours	240 Hours
	@-10±J	@-25±J	@-10±J	@-20±J	@-20±J	240 Hours
High Temperature & High Humidity	55±0%RH	75±0%RH	45±0%RH	65±0%RH	65±0%RH	240 Hours
	240 Hours	240 Hours	240 Hours	240 Hours	240 Hours	240 Hours
Thermal Shock	A	60min@-20±J	60min@-35±J	60min@-20±J	60min@-30±J	240 Hours
	B	5min@25±J	5min@25±J	5min@25±J	5min@25±J	240 Hours
	C	60min@70±J	60min@90±J	60min@70±J	60min@80±J	240 Hours
Expected Lift		50,000 Hours	50,000 Hours	50,000 Hours	50,000 Hours	50,000 Hours

Wide temp. version may not available for some products, Please consult our sales engineer or representative.

17. Functional Test & Inspection Criteria

17.1 Sample plan

Sample plan according to MIL-STD-105D level 2, and acceptance/rejection criteria is.

Base on : Major defect : AQL 0.65 Minor defect : AQL 2.5

17.2 Inspection condition

Viewing distance for cosmetic inspection is 30cm with bare eyes, and under an environment of 800 lus (20W) light intensity. All direction for inspecting the sample should be within 45° against perpendicular line.

17.3 Definition of Inspection Zone in LCD

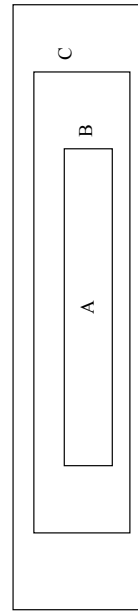

Zone A : Character / Digit area

Zone B : Viewing area except Zone A (Zone A + Zone B = minimum Viewing area)

Zone C : Outside viewing area (invisible area after assembly in customer's product)

Note : As a general rule, visual defects in Zone C are permissible, when it is no trouble for quality and assembly of customer's product.

17.4 Major Defect

All functional defects such as open (or missing segment), short, contrast differential, excess power consumption, smearing, leakage, etc. and overall outline dimension beyond the drawing. Are classified as major defects.



		Higher 4-bit (D4 to D7) of Character Code (Hexadecimal)																			
		0	1	2	3	4	5	6	7	8	9	A	B	C	D	E	F				
Lower 4-bit (D0 to D3) of Character Code (Hexadecimal)	0	User chr 0	!		0	1	2	3	4	5	6	7	8	9	A	B	C	D	E	F	
	1	User chr 1	!	!	!	!	!	!	!	!	!	!	!	!	!	!	!	!	!	!	!
	2	User chr 2	!	!	!	!	!	!	!	!	!	!	!	!	!	!	!	!	!	!	!
	3	User chr 3	!	!	!	!	!	!	!	!	!	!	!	!	!	!	!	!	!	!	!
	4	User chr 4	!	!	!	!	!	!	!	!	!	!	!	!	!	!	!	!	!	!	!
	5	User chr 5	!	!	!	!	!	!	!	!	!	!	!	!	!	!	!	!	!	!	!
	6	User chr 6	!	!	!	!	!	!	!	!	!	!	!	!	!	!	!	!	!	!	!
	7	User chr 7	!	!	!	!	!	!	!	!	!	!	!	!	!	!	!	!	!	!	!
	8	User chr 0	!	!	!	!	!	!	!	!	!	!	!	!	!	!	!	!	!	!	!
	9	User chr 1	!	!	!	!	!	!	!	!	!	!	!	!	!	!	!	!	!	!	!
	A	User chr 2	!	!	!	!	!	!	!	!	!	!	!	!	!	!	!	!	!	!	!
	B	User chr 3	!	!	!	!	!	!	!	!	!	!	!	!	!	!	!	!	!	!	!
	C	User chr 4	!	!	!	!	!	!	!	!	!	!	!	!	!	!	!	!	!	!	!
	D	User chr 5	!	!	!	!	!	!	!	!	!	!	!	!	!	!	!	!	!	!	!
	E	User chr 6	!	!	!	!	!	!	!	!	!	!	!	!	!	!	!	!	!	!	!
	F	User chr 7	!	!	!	!	!	!	!	!	!	!	!	!	!	!	!	!	!	!	!



APPENDIX B: ALPHABETICAL INDEX

B

BACKLIGHTING 16

BUTTONS 13, 16

BUZZER 12, 16

C

CAN 12

CARD VERSION 1

CONNECTORS 4

CN1 6

CN3 8

CN4 10

CN5 7

CPU 4

CURRENT 4

D

DEVICES 4

DIAGRAM 18

DISPLAY 13, 16

DSW 9

E

ELECTRIC DIAGRAM 18

I

I/O 8, 10, 12, 16

J

JUMPERS 14

K

KEYBOARD 16

L

LCD 13, 16

LEDS 13, 16

P

P1 12

PORT 8, 9, 10, 11

POWER SUPPLY 4, 6, 12

R

RELATIVE HUMIDITY 4

RESET 12

RS 232 7, 12

S

SIZE 4

T

TEMPERATURE RANGE 4

TTL 8, 10, 12, 16

V

VAC 6, 12

VDC 6, 12

VISUAL FEEDBACK 13

W

WEIGHT 4