

IBC 01

Interface Block Communication

TECHNICAL MANUAL

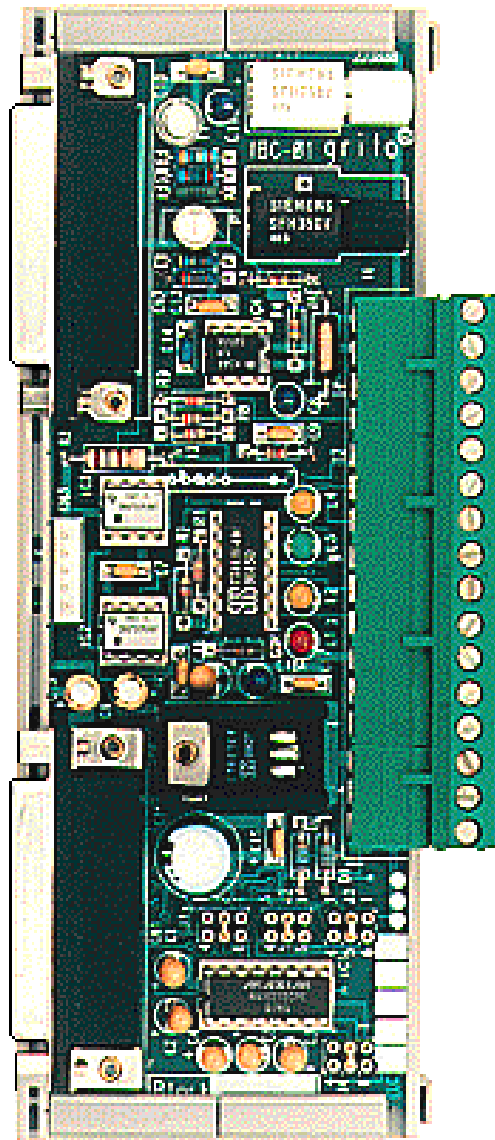

grifo[®]
ITALIAN TECHNOLOGY

Via dell' Artigiano, 8/6
40016 San Giorgio di Piano
(Bologna) ITALY
E-mail: grifo@grifo.it



<http://www.grifo.it> <http://www.grifo.com>
Tel. +39 051 892.052 (a. r.) FAX: +39 051 893.661

IBC 01 Edition 5.10 Rel. 04 October 1999

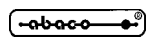
, GPC[®], grifo[®], are trade marks of grifo[®]

IBC 01

Interface Block Communication

TECHNICAL MANUAL

Serial communication protocols conversion/
extension module; 2 RS 232 serial lines; 1 RS 422
serial line; 1 optical fiber serial line; Selectable
DTE/DCE interface; container **DIN 46277-1 and
3** rails compliant

grifo[®]
ITALIAN TECHNOLOGY

Via dell' Artigiano, 8/6
40016 San Giorgio di Piano
(Bologna) ITALY
E-mail: grifo@grifo.it



<http://www.grifo.it> <http://www.grifo.com>
Tel. +39 051 892.052 (a. r.) FAX: +39 051 893.661

IBC 01

Edition 5.10

Rel. 04 October 1999

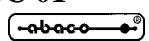
, GPC[®], grifo[®], are trade marks of grifo[®]

DOCUMENTATION COPYRIGHT BY grifo®, ALL RIGHTS RESERVED

No part of this document may be reproduced, transmitted, transcribed, stored in a retrieval system, or translated into any language or computer language, in any form or by any means, either electronic, mechanical, magnetic, optical, chemical, manual, or otherwise, without the prior written consent of **grifo®**.

IMPORTANT

Although all the information contained herein have been carefully verified, **grifo®** assumes no responsibility for errors that might appear in this document, or for damage to things or persons resulting from technical errors, omission and improper use of this manual and of the related software and hardware.

grifo® reserves the right to change the contents and form of this document, as well as the features and specification of its products at any time, without prior notice, to obtain always the best product.

For specific informations on the components mounted on the card, please refer to the Data Book of the builder or second sources.

SYMBOLS DESCRIPTION

In the manual could appear the following symbols:



Attention: Generic danger



Attention: High voltage

Trade Marks

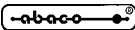
, **GPC®**, **grifo®** : are trade marks of **grifo®**.

Other Product and Company names listed, are trade marks of their respective companies.

GENERAL INDEX

| | |
|---|----|
| INTRODUCTION | 1 |
| CARD VERSION | 1 |
| GENERAL FEATURES | 2 |
| RS 232 SECTION | 3 |
| RS 422 SECTION | 3 |
| OPTICAL FIBER SECTION | 3 |
| COMMUNICATION SPEED | 3 |
| TECHNICAL FEATURES | 4 |
| GENERAL FEATURES | 4 |
| PHISYCAL FEATURES | 4 |
| ELECTRIC FEATURES | 4 |
| INSTALLATION | 6 |
| CONNECTIONS | 6 |
| OP1 AND OP2 - OPTICAL FIBER CONNECTORS | 6 |
| CN1 - MAIN RS 232 SERIAL INTERFACE CONNECTOR | 8 |
| CN2 - AUXILIARY RS 232 SERIAL INTERFACE CONNECTOR | 9 |
| CN3 - RS 422 SERIAL INTERFACE CONNECTOR | 10 |
| CN4 - QUICK RELEASE SCREW CONNECTOR | 11 |
| JUMPERS | 14 |
| INTRODUCTION | 14 |
| J1 - CN1 DTE/DCE INTERFACE SELECTION | 14 |
| J4 - CN2 DTE/DCE INTERFACE SELECTION | 15 |
| J2 - INTERFACE TYPE SELECTION | 16 |
| J3 - INTERFACE TYPE SELECTION | 16 |
| EXAMPLES OF CONNECTIONS | 18 |
| CONNECTION BETWEEN CN1 RS 232 AND CN2 RS 232 | 18 |
| CONNECTION BETWEEN CN1 RS 232 AND CN3 RS 422 | 18 |
| CONNECTION BETWEEN CN1 RS 232 AND OPTICAL FIBER OP1 - OP2 | 18 |
| CONNECTION BETWEEN CN3 RS 422 AND OPTICAL FIBER OP1 - OP2 | 18 |
| CONNECTION BETWEEN CN2 RS 232 AND CN3 RS 422 | 19 |
| CONNECTION BETWEEN CN2 RS 232 AND OPTICAL FIBER OP1 - OP2 | 19 |
| CONNECTION BETWEEN OPTICAL FIBER OP1 AND OP2 | 19 |
| LEDS VISUALIZATION | 20 |
| POWER SUPPLY | 20 |
| P1 - ON BOARD TRIMMER | 20 |
| EXTERNAL DEVICES FOR IBC 01 | 21 |
| APPENDIX A: ALPHABETICAL INDEX | A1 |

FIGURE INDEX

| | |
|--|-----------|
| FIGURE 1: CARD PHOTO | 5 |
| FIGURE 2: COMPONENTS MAP | 7 |
| FIGURE 3: CN1 - RS 232 MAIN CONNECTOR | 8 |
| FIGURE 4: CN2 - RS 232 AUXILIARY CONNECTOR | 9 |
| FIGURE 5: CN3 - RS 422 CONNECTOR | 10 |
| FIGURE 6: CN4 - INTERFACE TO ALL THE SIGNALS | 11 |
| FIGURE 7: RS 422 CONNECTION EXAMPLE | 12 |
| FIGURE 8: BLOCK DIAGRAM | 13 |
| FIGURE 9: J1 CONNECTIONS TO CONFIGURE CN1 AS DTE | 14 |
| FIGURE 10: J1 CONNECTIONS TO CONFIGURE CN1 AS DCE | 14 |
| FIGURE 11: J4 CONNECTIONS TO CONFIGURE CN2 AS DTE | 15 |
| FIGURE 12: J4 CONNECTIONS TO CONFIGURE CN2 AS DCE | 15 |
| FIGURE 13: JUMPER J2 | 16 |
| FIGURE 14: JUMPER J3 | 16 |
| FIGURE 15: JUMPERS, LEDs, CONNECTORS, ETC. LOCATION | 17 |
| FIGURE 16: LEDs MEANING TABLE | 20 |

INTRODUCTION

The use of these devices has turned - IN EXCLUSIVE WAY - to specialized personnel.

The purpose of this handbook is to give the necessary information to the cognizant and sure use of the products. They are the result of a continual and systematic elaboration of data and technical tests saved and validated from the manufacturer, related to the inside modes of certainty and quality of the information.

The reported data are destined- IN EXCLUSIVE WAY- to specialized users, that can interact with the devices in safety conditions for the persons, for the machine and for the environment, impersonating an elementary diagnostic of breakdowns and of malfunction conditions by performing simple functional verify operations , in the height respect of the actual safety and health norms.

The informations for the installation, the assemblage, the dismantlement, the handling, the adjustment, the reparation and the contingent accessories, devices etc. installation are destined - and then executable - always and in exclusive way from specialized warned and educated personnel, or directly from the TECHNICAL AUTHORIZED ASSISTANCE, in the height respect of the manufacturer recommendations and the actual safety and health norms.

The devices can't be used outside a box. The user must always insert the cards in a container that respect the actual safety normative. The protection of this container is not threshold to the only atmospheric agents, but specially to mechanic, electric, magnetic, etc. ones.

To be on good terms with the products, is necessary guarantee legibility and conservation of the manual, also for future references. In case of deterioration or more easily for technical updates, consult the AUTHORIZED TECHNICAL ASSISTANCE directly.

To prevent problems during card utilization, it is a good practice to read carefully all the informations of this manual. After this reading, the user can use the general index and the alphabetical index, respectly at the begining and at the end of the manual, to find information in a faster and more easy way.

CARD VERSION

The present handbook is reported to the **IBC 01** module release **220888** and later. The validity of the bring informations is subordinate to the number of the card release. The user must always verify the correct correspondence among the two denotations. On the card the release number is present in more points both board printed diagram (serigraph) and printed circuit (for example near SFH750V optical fiber connector).

GENERAL FEATURES

IBC 01 (Interface BLOCK Communication) is a BLOCK serie module that allows many serial communication interfacing combinations.

Every module is provided with two RS 232 serial lines, one RS 422 serial line and an optical fiber serial line, that can be combined simply by moving opportunly four set of jumpers.

To take the maximum advantage from the many features of the module, it is provided with all the connectors needed to interface it to the external world and with a visualization section, made of four LEDs, to watch its status in real time. The complete dotation of the system is:

- Two 25 pins female D connectors.
- One 16 pins quick release screw terminal connector.
- Two low cost plastic optical fiber connectors.
- One 5 pins low profile connector
- Four LEDs to visualize in real time the status of the connections.
- Stabilized power supply circuitry.

The main purposes of **IBC 01** module are:

- RS 232 repeater; this allows to double the length reachable with this protocol.
- RS 422 serial communication; the maximum distance reachable with this protocol is 1500 meters. It is also possible a cluster configuration for distributed systems.
- Optical fiber serial communication; this low cost communication solution allows to reach 50 meters of distance and performs a galvanic isolation of the units. The configuration allows the fibers to cross zones affected by a very strong electromagnetic pollution, for example near big electric engines or other powerful noise generators.

In order to simplify the identification of many IBC 01 modules installed in the same electrical control panel, a label, preceded by the BLOCK indication, has been made on the serigraph, so that the User can mark the device as preferred.

The module is secured in a plastic mount for connection to standard **DIN 46277-1** and **46277-3** omega rails, thereby dispensing with the need of a rack and allowing a less costly mounting direct to the electrical control panel.

RS 232 SECTION

IBC 01 is provided with two independent sections for interfacing to RS 232 serial communication lines. One of these is the primary serial line, that is the line which can be switched directly to any of the remaining communication sections. The signals of these lines are connected to the 25 pins female D connectors and consist of the RxD and TRxD (reception and transmission) signals, therefore no hardware handshake is present.

RS 422 SECTION

The RS 422 serial communication section installed on **IBC 01** module is a complete differential serial device for interfacing the TxD and RxD communication lines. These signals are connected to a 5 pins low profile connector featuring the **Abaco®** standard pin out.

OPTICAL FIBER SECTION

A low cost optical fiber communication section is installed on **IBC 01** module. Also this section is provided only with **RxD** and **TxD** (reception and transmission) signals, that are connected to comfortable **ESKA 4001** type plastic optical fiber connectors, measuring 34 mm of external diameter and 1 mm of internal diameter.

COMMUNICATION SPEED

All the serial communication section on **IBC 01** module can work at 19200 Baud, also in very noisy environments. Higher speeds may be reached but should be tested directly on the application.

TECHNICAL FEATURES

GENERAL FEATURES

Lines number:
2 RS 232 lines
1 RS 422 lines
1 Optical fiber line

PHISYCAL FEATURES

Size: 168 x 72 x 45 mm

Weight: 132 g

Connectors:
CN1: 25 pins female D connector
CN2: 25 pins female D connector
CN3: 5 pins, vertical, low profile connector
CN4: 16 pins, quick release, screw terminal connector
OP2: Optical fiber, SFH750V transmission connector
OP2: Optical fiber, SFH750V or SFH350 reception connector

Optical fiber: ESKA 4001 type, in plastic, measuring 3 mm of external diameter and 1 mm of internal diameter

Temperature range: from 0 to 50 centigrad degrees

Relative humidity: from 20% to 90% (without condense)

ELECTRIC FEATURES

Power supply: +5 Vdc stabilized or from 8 to 12 Vdc

Consumption: 70 mA

Current supplied on +5 Vdc: 100 mA max

INSTALLATION

In this chapter there are all information for a right installation and correct use of the card. The User can find the location and functions of each connectors, LEDs, jumpers and some explanatory diagram.

CONNECTIONS

The **IBC 01** module has a set of connectors that can be linked to other devices or directly to the field. In this paragraph there are connectors pin out, a brief signals description, connectors location (see figure 15) and some electrical diagrams.

OP1 AND OP2 - OPTICAL FIBER CONNECTORS

The **IBC 01** module implements also a low cost, 3 mm diameter, plastic optical fiber ranging 50 meters as maximum distance between terminals.

The transmitter is contained in a low cost plastic connector called Siemens SFH750, whose working status is shown by the green LED L3.

The receiver, contained in a low cost plastic connector like the transmitter, normally is a Siemens SFH250 but it is also possible to mount an SFH350 if the User requests it in the ordering phase. Also the receiver's working status is shown by a LED, yellow, called L2.

Connecting the optical fiber to the **OP1** and **OP2** connector must be executed in strict respect of the following specifications:

- Cut the optical fiber with a sharpened blade, the cut shall be sharp and perpendicular to the fiber axis;
- Open completely the ring nut of the connector;
- Insert the fiber in the connector, exercising a light pressure, so assure the effective contact of the fiber to the end of the connector;
- Close firmly the ring nut of the connector.

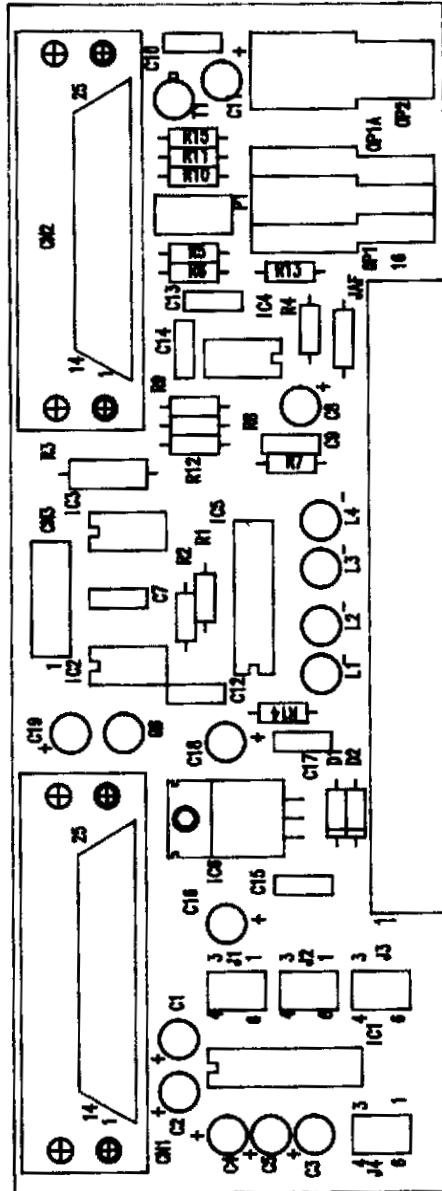

FIGURE 2: COMPONENTS MAP

CN1 - MAIN RS 232 SERIAL INTERFACE CONNECTOR

CN1 is a 25 pins, female, D type connector by which the User can interface to all the signals of the module (one RS 232 interface, one RS 422 interface and one optical fiber interface) having opportunely configured the jumpers to reach the interface desired.

The Jumpers J1 allow to swap quickly the signals on pins 2 and 3 of the CN1 connector, switching the module from DTE to DCE configuration and viceversa. By this feature it is possible to fit immediatly to any need of interfacement.

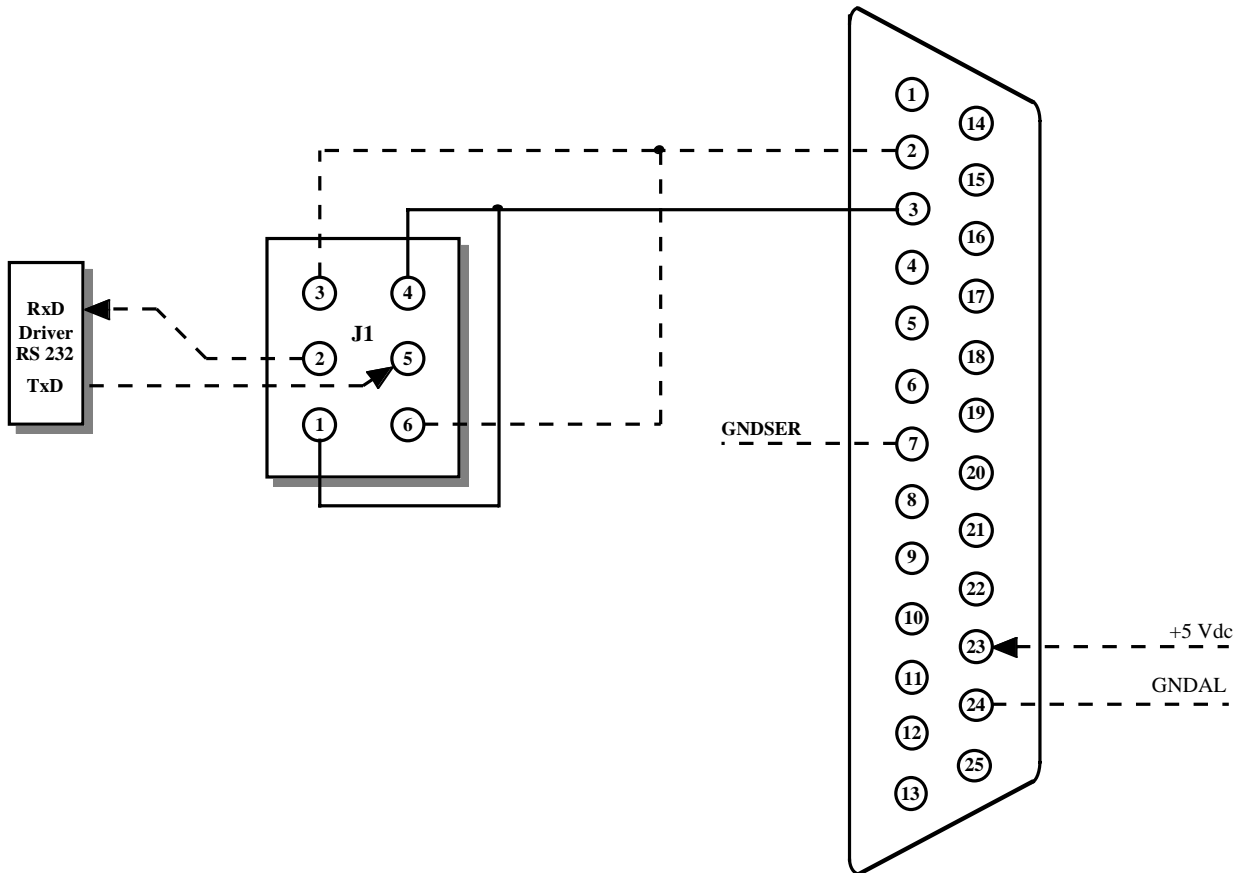

FIGURE 3: CN1 - RS 232 MAIN CONNECTOR

Signals description:

| | | | |
|---------------|---|---|------------------------------------|
| TxD | = | O | - RS 232 serial transmit signal |
| RxD | = | I | - RS 232 serial receive signal |
| GNDSER | = | | - RS 232 serial line ground signal |
| +5 Vdc | = | I | - Stabilized supply of the module |
| GNDAL | = | | - Stabilized supply ground signal |

The remaining pins are not connected.

CN2 - AUXILIARY RS 232 SERIAL INTERFACE CONNECTOR

CN2 is a 25 pins, female, D type connector with characteristics similar to CN1.

The main difference between this connector and CN1 is the absence of the possibility to connect to the other serial communication sections by Jumpers J2 and J3, but only by a wire rap bridging or wire connections. The only direct connection allowed by the Jumpers is to the RS 232 serial line of CN1. The Jumpers J4 allow to swap quickly the signals on pins 2 and 3 of the CN2 connector, switching the module from DTE to DCE configuration and viceversa. By this feature it is possible to fit immediatly to any need of interfacement.

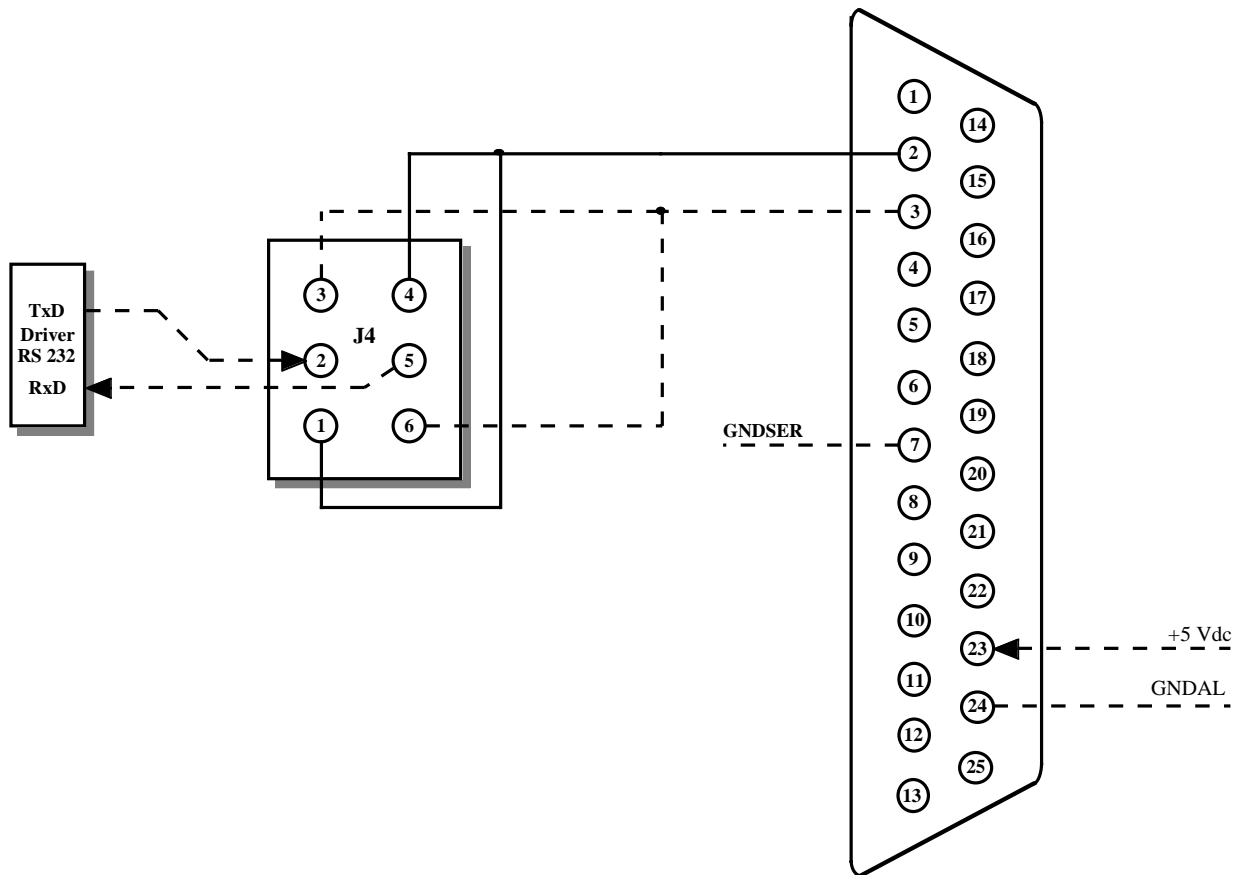

FIGURE 4: CN2 - RS 232 AUXILIARYCONNECTOR

Signals description:

- TxD** = O - RS 232 serial transmit signal
- RxD** = I - RS 232 serial receive signal
- GNDSER** = - RS 232 serial line ground signal
- +5 Vdc** = I - Stabilized supply of the module
- GNDAL** = - Stabilized supply ground signal

The remaining pins are not connected.

CN3 - RS 422 SERIAL INTERFACE CONNECTOR

CN3 is a 5 pins, vertical, low profile connector where the RS 422 serial line signals are connected. The pin out of this connector follows the **Abaco**[®] standard disposition, in order to easy the connection to other boards rovided with this kind of serial communicatoin interface.

The pin out of this connector follows the **Abaco**[®] standard disposition, in order to easy the connection to other boards rovided with this kind of serial communicatoin interface.

If the **IBC01** module is connected as transmitter at an extremity of the RS 422 network, an oportune termination resistor must be connected as a termination resistor, for example on the CN4 connector. The value of the resistor is related to the impedance of the transmission line.

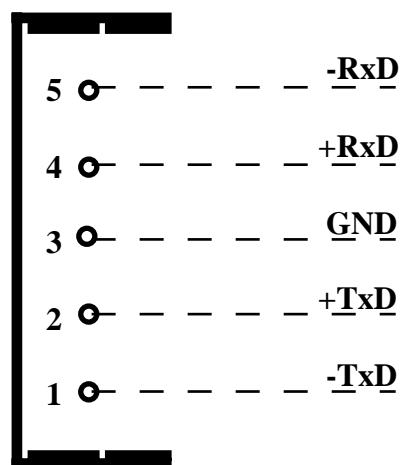

FIGURE 5: CN3 - RS 422 CONNECTOR

Signals description:

| | | | | |
|-------------|---|---|---|---|
| TxD- | = | O | - | Transmit Data Negative: negative line for RS 422 serial differential transmit |
| TxD+ | = | O | - | Transmit Data Positive: positive line for RS 422 serial differential transmit |
| GND | = | | - | Serial line ground signa |
| RxD- | = | I | - | Receive Data Negative: negative line for RS 422 serial differential receive |
| RxD+ | = | I | - | Receive Data Positive: positive line for RS 422 serial differential receive |

| | | | | |
|------------------|---|-----|---|---|
| TxD- | = | O | - | Transmit Data Negative: negative line for RS 422 serial differential transmit |
| TxD+ | = | O | - | Transmit Data Positive: positive line for RS 422 serial differential transmit |
| RxD- | = | I | - | Receive Data Negative: negative line for RS 422 serial differential receive |
| RxD+ | = | I | - | Receive Data Positive: positive line for RS 422 serial differential receive |
| TxD O.F. | = | O | - | Optical fiber section transmit signal (TTL) |
| RxD O.F. | = | I | - | Optical fiber section receive signal (TTL) |
| Pin 3 CN2 | = | I/O | - | Receive/transmit signal (according to J4) of the RS 232 auxiliary serial line |
| Pin 2 CN2 | = | O/I | - | Transmit/receive signal (according to J4) of the RS 232 auxiliary serial line |
| Pin 3 CN1 | = | I/O | - | Receive/transmit signal (according to J1) of the RS 232 primary serial line |
| Pin 2 CN1 | = | O/I | - | Transmit/receive signal (according to J1) of the RS 232 primary serial line |

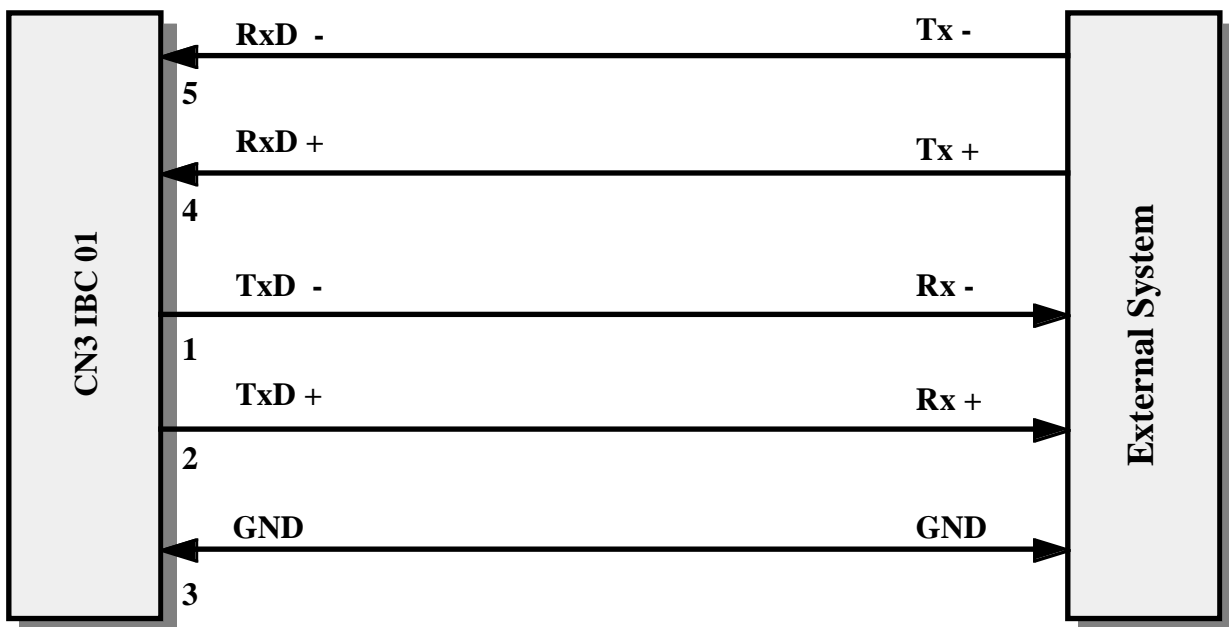

FIGURE 7: RS 422 CONNECTION EXAMPLE

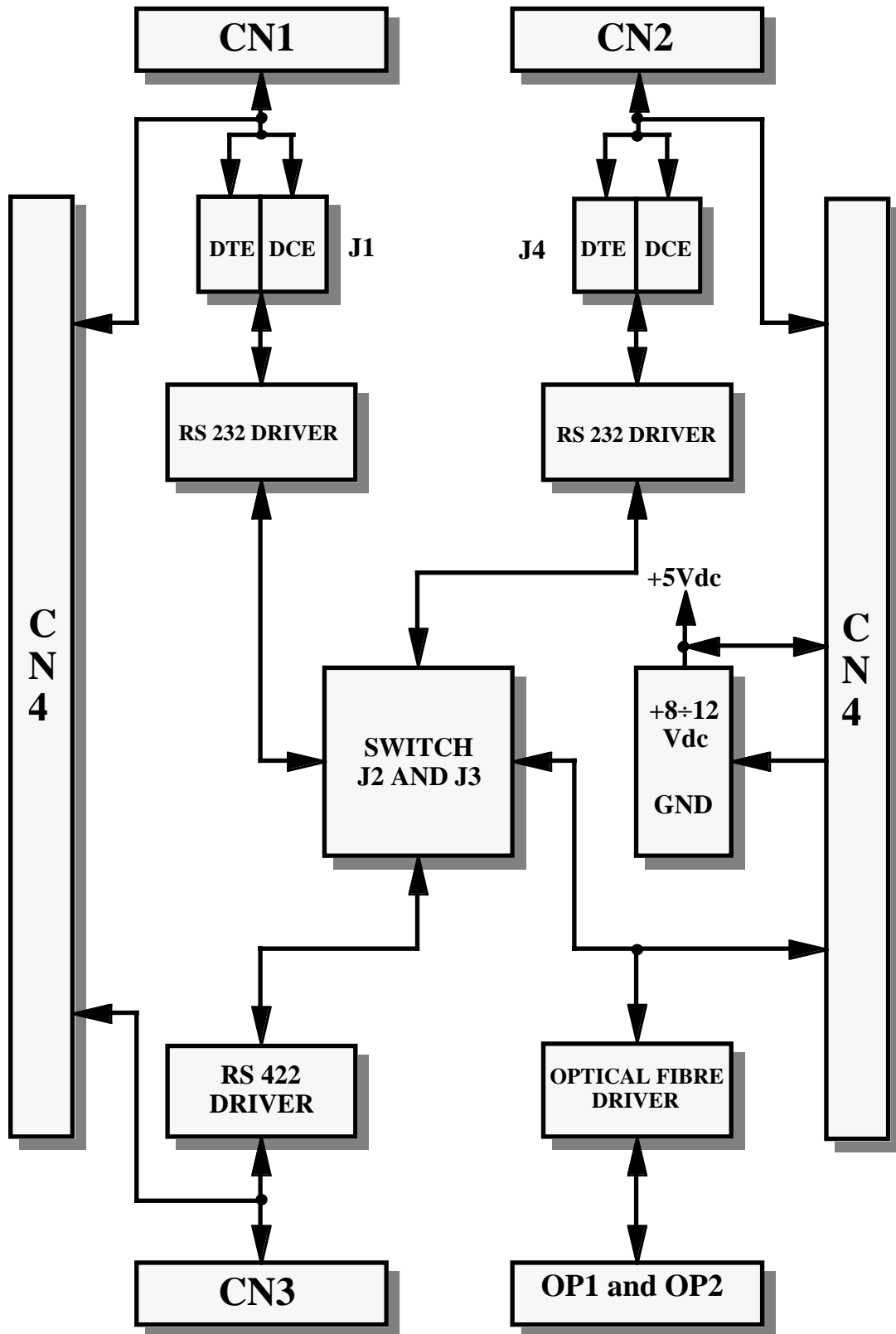

FIGURE 8: BLOCK DIAGRAM

JUMPERS

INTRODUCTION

This chapter shows the possible connections for the 4 sets of jumpers (2x3 pins) called J1, J2, J3 and J4 providing also a description for the signals connected.

To simplify the comprehension of their use, here follow both a generic description for every contact and some examples of connection.

To easily locate these devices on the board please refer to figure 15.

J1 - CN1 DTE/DCE INTERFACE SELECTION

Jumper J1 allows the User to select the type of pin out on CN1 25 pins female D connector.

Valid connections for the jumper are two, that configure CN1 for a Data Terminal Equipment or a Data Communication Equipment pin out. In detail:

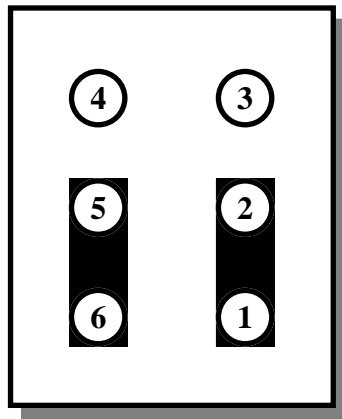

FIGURE 9: J1 CONNECTIONS TO CONFIGURE CN1 AS DTE

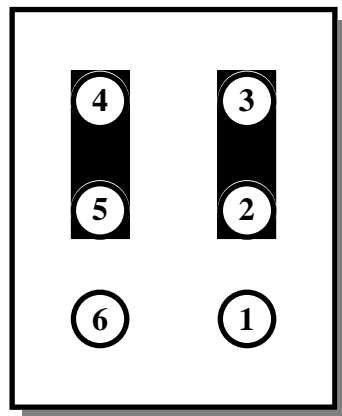

FIGURE 10: J1 CONNECTIONS TO CONFIGURE CN1 AS DCE

The default connection is: CN1 (primary RS 232 interface) configured as DCE

J4 - CN2 DTE/DCE INTERFACE SELECTION

Jumper J4 allows the User to select the type of pin out on CN2 25 pins female D connector. Valid connections for the jumper are two, that configure CN2 for a Data Terminal Equipment or a Data Communication Equipment pin out. In detail:

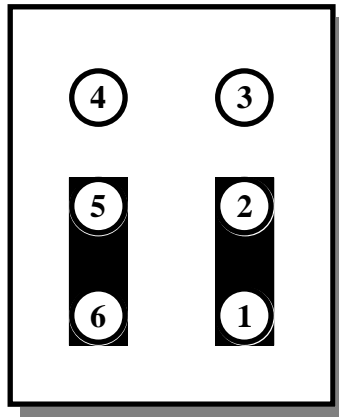

FIGURE 11: J4 CONNECTIONS TO CONFIGURE CN2 AS DTE

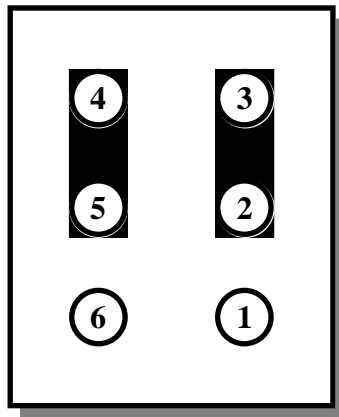

FIGURE 12: J4 CONNECTIONS TO CONFIGURE CN2 AS DCE

The default connection is: CN2 (auxiliary RS 232 interface) configured as DTE

J2 - INTERFACE TYPE SELECTION

Jumper J2 (matched with J3) allows the User to select the interface type by which to use the **IBC 01** module. In detail J2 and J3 determine which of the four serial communication sections to connect together. All the signals shown are TTL. Here follows a description of the signals connected on J2:

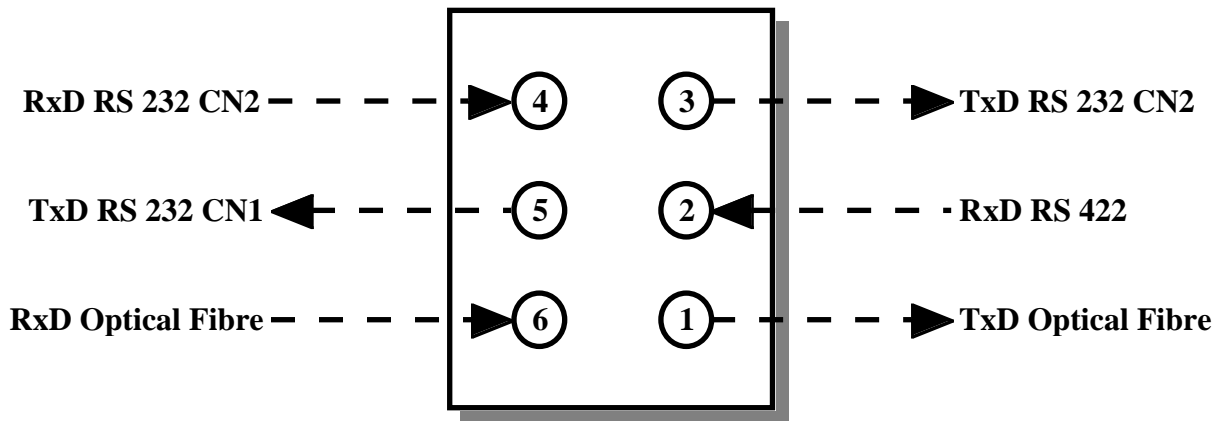

FIGURE 13: JUMPER J2

J3 - INTERFACE TYPE SELECTION

Jumper J3 (matched with J2) allows the User to select the interface type by which to use the **IBC 01** module. In detail J2 and J3 determine which of the four serial communication sections to connect together. All the signals shown are TTL. Here follows a description of the signals connected on J3:

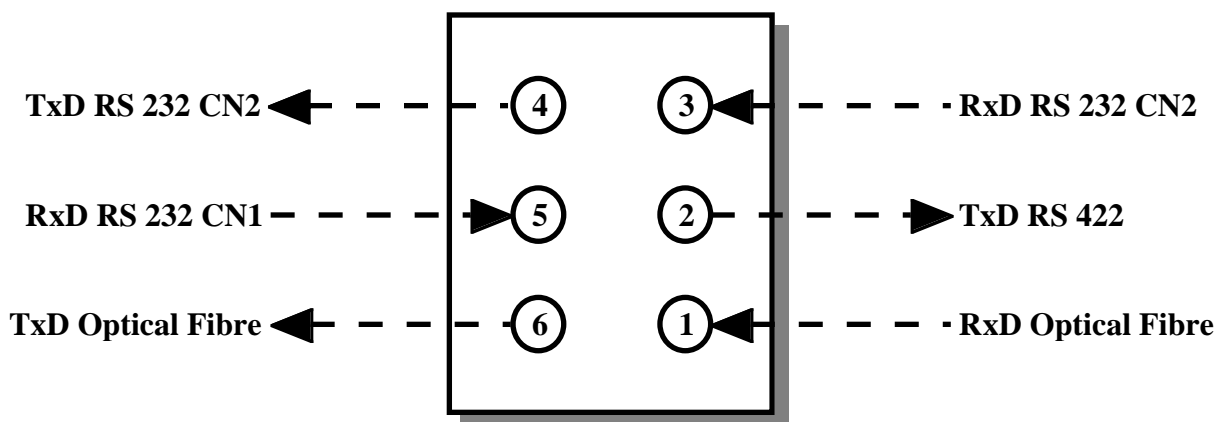

FIGURE 14: JUMPER J3

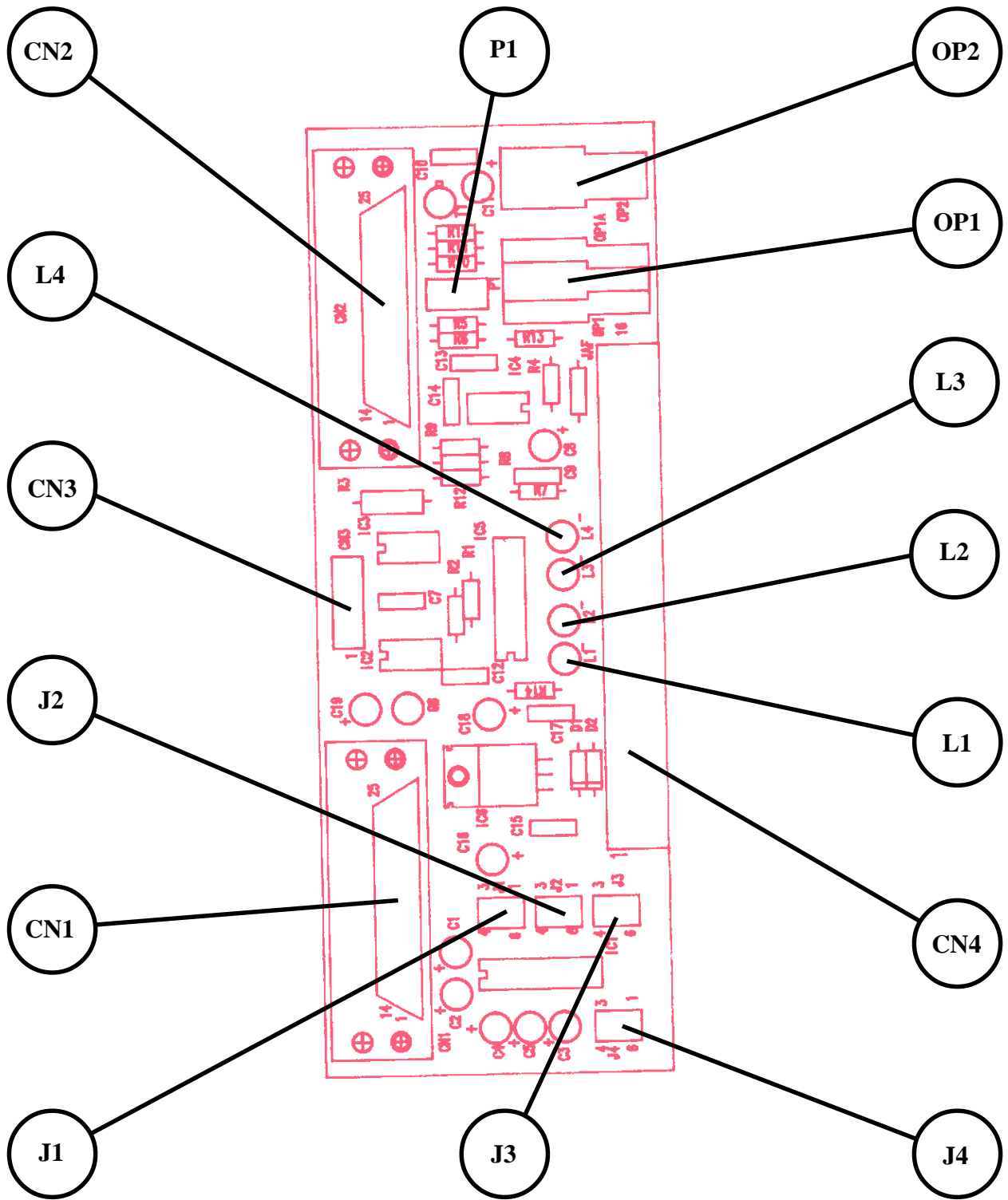

FIGURE 15: JUMPERS, LEDs, CONNECTORS, ETC. LOCATION

EXAMPLES OF CONNECTIONS

Here follow all the connections normally used on the **IBC 01** module obtained configuring opportunely jumpers J2 and J3.

As the User can see in figure 8, the receipt and transmit section of any serial line on the module are independent, allowing many possible combinations.

The board supports also particular combinations not configurable using the jumpers, that can be obtained, for example, using the wire rap technique. In such cases the User should only be careful to the direction and type of the signals involved.

EXAMPLE - CONNECTION BETWEEN CN1 RS 232 AND CN2 RS 232

This connection creates essentially an RS 232 repeater, to extend the maximum distance reachable by this protocol. It can be obtained with this connections:

J2 connected in position 4-5
J3 connected in position 4-5

EXAMPLE - CONNECTION BETWEEN CN1 RS 232 AND CN3 RS 422

This connection creates essentially a converter between the main RS 232 serial line and the RS 422 differential serial line. It can be obtained with this connections:

J2 connected in position 2-5
J3 connected in position 2-5

EXAMPLE - CONNECTION BETWEEN CN1 RS 232 AND OPTICAL FIBER OP1 - OP2

This connection creates essentially a converter between the main RS 232 serial line and the optical fiber serial line. It can be obtained with this connections:

J2 connected in position 5-6
J3 connected in position 5-6

EXAMPLE - CONNECTION BETWEEN CN3 RS 422 AND OPTICAL FIBER OP1 - OP2

This connection creates essentially a converter between the RS 422 serial line and the optical fiber serial line. It can be obtained with this connections:

J2 connected in position 1-2
J3 connected in position 1-2

EXAMPLE - CONNECTION BETWEEN CN2 RS 232 AND CN3 RS 422

This connection creates essentially a converter between the auxiliary RS 232 serial line and the RS 422 differential serial line. It can be obtained with this connections:

J2 connected in position 2-3

J3 connected in position 2-3

EXAMPLE - CONNECTION BETWEEN CN2 RS 232 AND OPTICAL FIBER OP1 - OP2

This connection creates essentially a converter between the auxiliary RS 232 serial line and the optical fiber serial line. It can be obtained with this connections:

J2 connected in position 1-4 and 3-6

alternatively

J3 connected in position 1-4 and 3-6

This connection must be performed using the wire rap technique.

EXAMPLE - CONNECTION BETWEEN OPTICAL FIBER OP1 AND OP2

This connection creates essentially an optical fiber serial line repeater. It can be obtained with this connections:

J2 connected in position 1-6

alternatively

J3 connected in position 1-6

This connection allows the User to create a full duplex, 100 meters long optical fiber serial connection just employing two **IBC 01** modules.

LEDS VISUALIZATION

IBC 01 module is provided with four status LEDs that visualize the working conditions set by the User configuring the jumpers.

A red LED, if ON, indicates the presence of the power supply voltage (+5 Vdc); a green and a yellow LEDs indicate respectively transmit and receive in the optical fiber serial line; a yellow LED indicates the use of the main RS 232 serial line.

| LED | INDICATION |
|-----------------|--|
| L1 - Red LED | If ON, indicates the presence of the module's power supply |
| L2 - Yellow LED | If ON, indicates data receive in progress on the optical fiber line |
| L3 - Green LED | If ON, indicates data transmit in progress on the optical fiber line |
| L4 - Yellow LED | If ON, indicates data receive or transmit in progress on the main RS 232 serial line (CN1) |

FIGURE 16: LEDS MEANING TABLE

POWER SUPPLY

The **IBC 01** module can be supplied in two ways:

- A) Stabilized +5V dc voltage that can be provided to the module by pins 23 and 24 of the serial interface D connector or accessing directly pins 16 and 15 of CN4 connector.
- B) 8 ÷ 12 Vdc, not necessarily stabilized direct current, that must be provided directly on pins 14 and 15 of CN4.

The presence of power supply is always signaled by the above mentioned L1 red LED.

P1 - ON BOARD TRIMMER

The **IBC 01** module is provided with an on-board trimmer, called **P1**, connected to the receive section of the optical fiber line. The purpose of this trimmer is to set the threshold of the receive comparator, this means to decide the sensibility of the optical fiber receiver (SFH250 or SFH350).

This trimmer can be accessed only by **grifo**® technical personnel.

EXTERNAL DEVICES FOR IBC 01

IBC 01 can be connected to a wide range of **grifo®** cards and to many system of other companies. Hereunder these cards are listed, for further information please call **grifo®**.

QTP 22

Quick Terminal Panel 22 keys

Intelligent user panel equipped with alphanumeric LCD or fluorescent display (40x1, 40x2 or 40x4 characters); RS 232, RS 422-485 or Current Loop serial lines; serial EEPROM for set-up and messages; Possibility of re-naming the 22 keys and name panel by inserting label with new name into the proper slot ; 22 LEDs with blinking attribute and Buzzer manageable by software ; built-in 24 Vac power supply; RTC option, reader of magnetic badge and relays.

QTP 24

Quick Terminal Panel 24 keys

Intelligent user panel equipped with Fluorescent 20x2 or LCD display, LEDs backlit, 20x2 or 20x4 characters; RS 232, RS 422-485 or Current Loop serial lines; serial EEPROM for set-up and messages; Possibility of re-naming keys, LEDs and panel name by inserting label with new name into the proper slot ; 24 keys and 16 LEDs with blinking attribute and Buzzer manageable by software ; built-in power supply; RTC option, reader of magnetic badge and relays.

QTP G26

Quick Terminal Panel LCD Graphic

Intelligent user panel equipped with graphic LCD display 240x120 pixels, LEDs backlit; 1RS 232 line , additional RS 232, RS 422-485 or Current Loop lines; serial EEPROM for set-up; 256K EPROM, FLASH and EEPROM; RTC and 128K RAM; primary graphic object; Possibility of re-naming keys, LEDs and panel name by inserting label with new name into the proper slot , 16 keys and 16 LEDs, Buzzer, built-in power supply.

IPC 51

Intelligent Pheripheral Controller

This Intelligent peripheral card acquires 8 temperature sensors PT 100 type or thermo couple J, K, S, T type; BUS interfacing or through RS 232, RS 422-485 or Current Loop line; 16 Bits + sign A/D section; 5 or 8 conversion per second; 0,1 °C resolution.

UAR 24

Universal Analog Regulator

This Intelligent peripheral card acquires 2 temperature sensors PT 100 type or 2 thermo couple J, K, S, T type; 4 3 A relays output; 2 D/A outputs 12 bits 0÷10 Vdc each; BUS interfacing or through RS 232, RS 422-485 or Current Loop line; 16 Bits + sign A/D section



APPENDIX A: ALPHABETICAL INDEX

A**ABACO® 10****B****BLOCK DIAGRAM 13****C****CARD VERSION 1****COMMUNICATION SPEED 3****CONNECTORS 2, 4, 6, 17****CONSUMPTION 4****CONVERTER 18, 19****CURRENT SUPPLIED 4****E****ESKA 4001 4****EXAMPLES 18****EXTERNAL DEVICES 21****F****FEATURES 4****G****GENERAL FEATURES 2****I****INSTALLATION 6****INTRODUCTION 1****J****JUMPERS 6, 8, 9, 14, 17, 18****J1 14****J2 16, 18, 19****J3 16, 18, 19****J4 15****L****LEDS 2, 6, 17****LEDS VISUALIZATION 20****O****OPTICAL FIBER 2, 3, 4, 6, 11, 18, 20****P****P1 20****POWER SUPPLY 4, 11, 20**

R

RELATIVE HUMIDITY 4

REPEATER 2, 18, 19

RS 232 2, 3, 4, 8, 9, 11, 14, 15, 18, 19

RS 422 2, 3, 4, 10, 11, 18, 19

S

SFH250 20

SFH350 4, 20

SFH750V 4

SIZE 4

STABILIZED SUPPLY 8, 9, 11

T

TEMPERATURE RANGE 4

THRESHOLD 20

TRIMMER 20

TTL 12, 16

W

WEIGHT 4