

MB3 01

Mother Board ABACO® 3 slot

TECHNICAL MANUAL

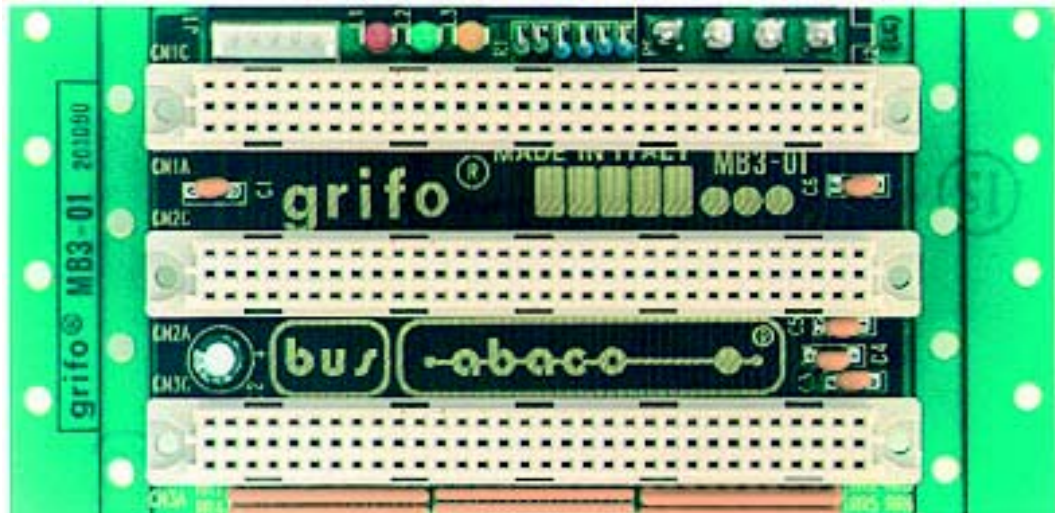

grifo®
ITALIAN TECHNOLOGY

Via dell' Artigiano, 8/6
40016 San Giorgio di Piano
(Bologna) ITALY
E-mail: grifo@grifo.it



<http://www.grifo.it> <http://www.grifo.com>
Tel. +39 051 892.052 (a. r.) FAX: +39 051 893.661

MB3 01

Rel. 5.10

Rel. 11 April 2003

®, GPC®, **grifo**®, are trade marks of **grifo**®



MB3 01

Mother Board ABACO® 3 slot

TECHNICAL MANUAL

Size **160x65x30** mm for **3 HE** racks; slots pitch **4 TE**; double row of holes for mounting pitch **3 TE**; Mother Boards featuring **3 ABACO® BUS** slots for Eurocard standard 100x160 mm size boards with **DIN 41612 A+C** type C connectors; **3 LEDs** for showing status of power supplies; **noise filters** on supply lines; termination resistors on BUS lines to warrant correct working in case of lines not connected or driven by CMOS; low profile connector for **remote connection of LEDs and RESET key**; AMP connector for power supply voltages **+5 Vdc, +12 Vdc and -12 Vdc** remote connection.

grifo®
ITALIAN TECHNOLOGY

Via dell' Artigiano, 8/6
40016 San Giorgio di Piano
(Bologna) ITALY
E-mail: grifo@grifo.it



<http://www.grifo.it> <http://www.grifo.com>
Tel. +39 051 892.052 (a. r.) FAX: +39 051 893.661

MB3 01

Rel. 5.10

Rel. 11 April 2003

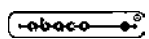
, GPC®, grifo®, are trade marks of grifo®

DOCUMENTATION COPYRIGHT BY grifo®, ALL RIGHTS RESERVED

No part of this document may be reproduced, transmitted, transcribed, stored in a retrieval system, or translated into any language or computer language, in any form or by any means, either electronic, mechanical, magnetic, optical, chemical, manual, or otherwise, without the prior written consent of **grifo®**.

IMPORTANT

Although all the information contained herein have been carefully verified, **grifo®** assumes no responsibility for errors that might appear in this document, or for damage to things or persons resulting from technical errors, omission and improper use of this manual and of the related software and hardware.

grifo® reserves the right to change the contents and form of this document, as well as the features and specification of its products at any time, without prior notice, to obtain always the best product.

For specific informations on the components mounted on the card, please refer to the Data Book of the builder or second sources.

SYMBOLS DESCRIPTION

In the manual could appear the following symbols:



Attention: Generic danger



Attention: High voltage

Trade Marks

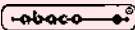
, **GPC®**, **grifo®** : are trade marks of **grifo®**.

Other Product and Company names listed, are trade marks of their respective companies.

GENERAL INDEX

INTRODUCTION	1
CARD VERSION	1
GENERAL FEATURES	2
TECHNICAL FEATURES OF MB3 01	4
GENERAL FEATURES OF MB3 01	4
PHYSICAL FEATURES OF MB3 01	4
ELECTRIC FEATURES OF MB3 01	4
INSTALLATION	6
CONNECTIONS	6
J1 - REMOTE CONNECTION OF RESET KEY AND LEDS	6
J2 - POWER SUPPLY CONNECTOR	8
TERMINATION RESISTORS	9
CN1÷CN3 - ABACO® BUS CONNECTORS	10
VISUAL SIGNALATIONS	12
EXTERNAL CARDS	13
APPENDIX A: ALPHABETICAL INDEX	A-1

FIGURE INDEX

FIGURE 1: BLOCK DIAGRAM	3
FIGURE 2: CARD PHOTO	5
FIGURE 3: J1 - CONNECTOR FOR REMOTE RESET KEY AND LEDs	6
FIGURE 4: CONNECTORS AND LEDs LOCATION	7
FIGURE 5: J2 - POWER SUPPLY CONNECTOR	8
FIGURE 6: COMPONENTS MAP	9
FIGURE 7: CN1÷CN3 - ABACO® BUS CONNECTORS	10
FIGURE 8: VISUAL SIGNALATIONS TABLE	12
FIGURE 9: LEDs CONNECTION DIAGRAM	12
FIGURE 10: POSSIBLE CONNECTIONS DIAGRAM	15

INTRODUCTION

The use of these devices has turned - IN EXCLUSIVE WAY - to specialized personnel.

The purpose of this handbook is to give the necessary information to the cognizant and sure use of the products. They are the result of a continual and systematic elaboration of data and technical tests saved and validated from the manufacturer, related to the inside modes of certainty and quality of the information.

The reported data are destined- IN EXCLUSIVE WAY- to specialized users, that can interact with the devices in safety conditions for the persons, for the machine and for the environment, impersonating an elementary diagnostic of breakdowns and of malfunction conditions by performing simple functional verify operations , in the height respect of the actual safety and health norms.

The information for the installation, the assemblage, the dismantlement, the handling, the adjustment, the reparation and the contingent accessories, devices etc. installation are destined - and then executable - always and in exclusive way from specialized warned and educated personnel, or directly from the TECHNICAL AUTHORIZED ASSISTANCE, in the height respect of the manufacturer recommendations and the actual safety and health norms.

The devices can't be used outside a box. The user must always insert the cards in a container that respect the actual safety normative. The protection of this container is not threshold to the only atmospheric agents, but specially to mechanic, electric, magnetic, etc. ones.

To be on good terms with the products, is necessary guarantee legibility and conservation of the manual, also for future references. In case of deterioration or more easily for technical updates, consult the AUTHORIZED TECHNICAL ASSISTANCE directly.

To prevent problems during card utilization, it is a good practice to read carefully all the information of this manual. After this reading, the user can use the general index and the alphabetical index, respectly at the begining and at the end of the manual, to find information in a faster and more easy way.

CARD VERSION

The present handbook is reported to **MB3 01** module release **260196** and later. The validity of the bring information is subordinate to the number of the module release. The user must always verify the correct correspondence among the two denotations. On the module the release number is present in more points both board printed diagram (serigraph) and printed circuit (for example between CN1 and CN2 on both the sides).

GENERAL FEATURES

Back panel **MB3 01** has been designed in order to provide the user supports for interfacement to **BUS ABACO®** cards.

They feature all the fastening for mounting on every rack for three units (3 HE) and three slots for interfacement to **BUS ABACO®** cards.

MB3 01 is suitable for applications that require up to three **BUS ABACO®** cards in a reduced room and with optimization of total system costs.

Should the modules be too few or too many for the application, any other model of back panel from **grifo®** listing can be used.

Mother board is provided with a connector to remote the reset key and the LEDs that indicate the presence of supply voltages.

This feature allows to install LEDs and reset key also at distance from the electronic cards, for example in the front panel of a rack.

Overall features are:

- Size **160x65x30** mm for **3 HE** racks
- Slots pitch **4 TE**
- Double row of holes for mounting pitch **3 TE**
- Mother Boards featuring **3 ABACO® BUS** slots for Eurocard standard 100x160 mm size boards with **DIN 41612 A+C** type C connectors
- **3 LEDs** for showing status of power supplies
- **Noise filters** on supply lines
- Termination resistors on BUS lines to warrant correct working in case of lines not connected or driven by CMOS
- Low profile connector for **remote connection of LEDs and RESET key**
- AMP connector for power supply voltages **+5 Vdc, +12 Vdc and -12 Vdc** remote connection

Here follow the block diagrams of the cards.

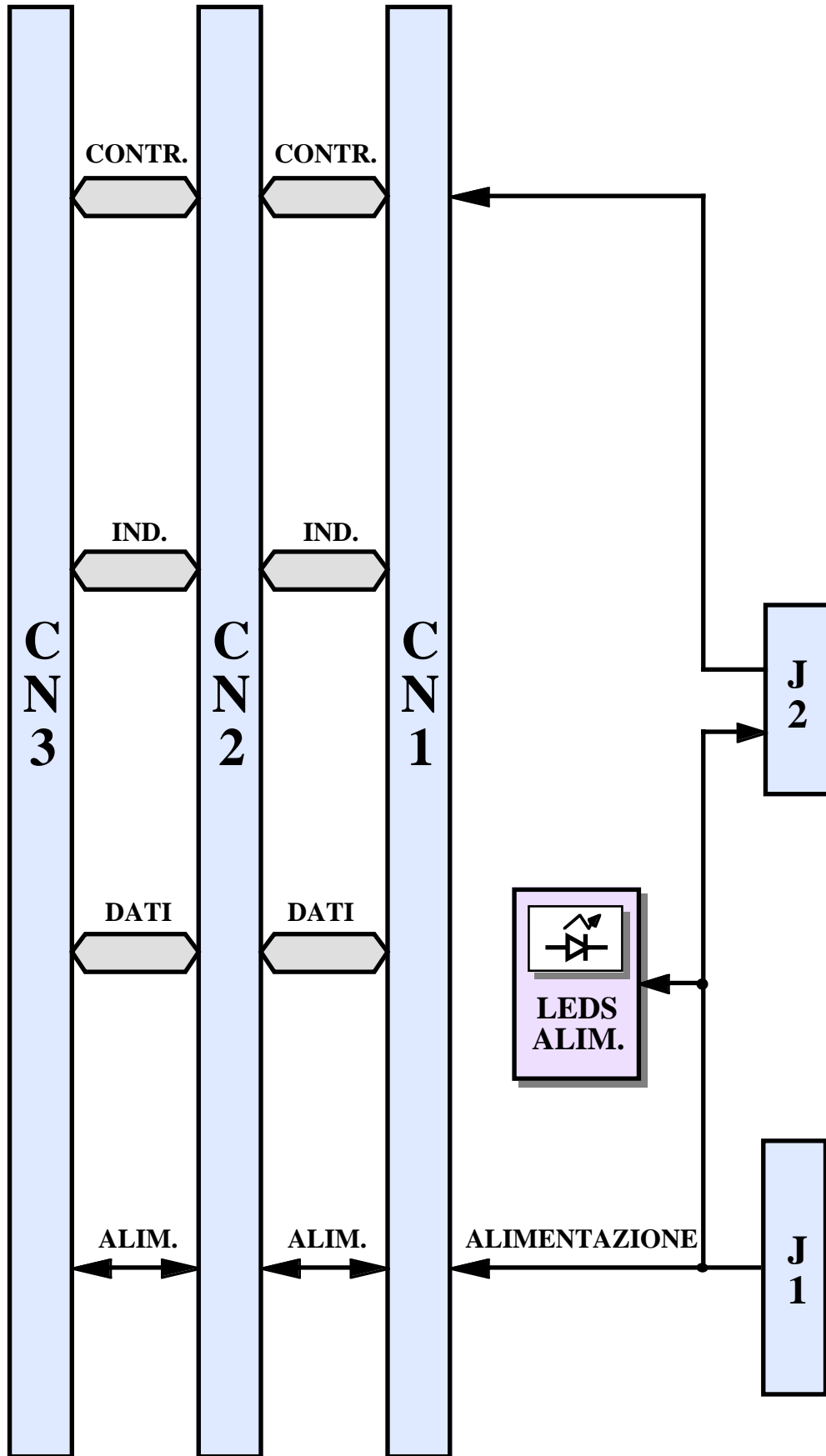

FIGURE 1: BLOCK DIAGRAM

TECHNICAL FEATURES OF MB3 01

GENERAL FEATURES OF MB3 01

BUS type:	BUS ABACO®
Devices:	3 slots for BUS ABACO® 1 local reset key 1 connectors for remote reset key and LEDs 3 LEDs to visualize power supply status
BUS line type:	termination by resistors
Power supply:	provided with noise reduction filters

PHYSICAL FEATURES OF MB3 01

Size:	130 x 65 x 80 mm, for rack 3 HE
Slots pitch:	4 TE
Mounting:	double row of holes pitch 3 TE, diameter 2.5 mm
Weight:	90 g
Connectors:	J1: 5 pins, male, vertical, low profile connector J2: 4 pins AMP MATE N LOK, male vertical CN1÷CN3: 64 pins DIN 41612 A+C type C, vertical, female
Temperature range:	0÷70 °C
Relative humidity:	20%÷90% (without condense)

ELECTRIC FEATURES OF MB3 01

Power supply:	+5 Vdc 15 mA
	+12 Vdc 15 mA
	-12 Vdc 15 mA

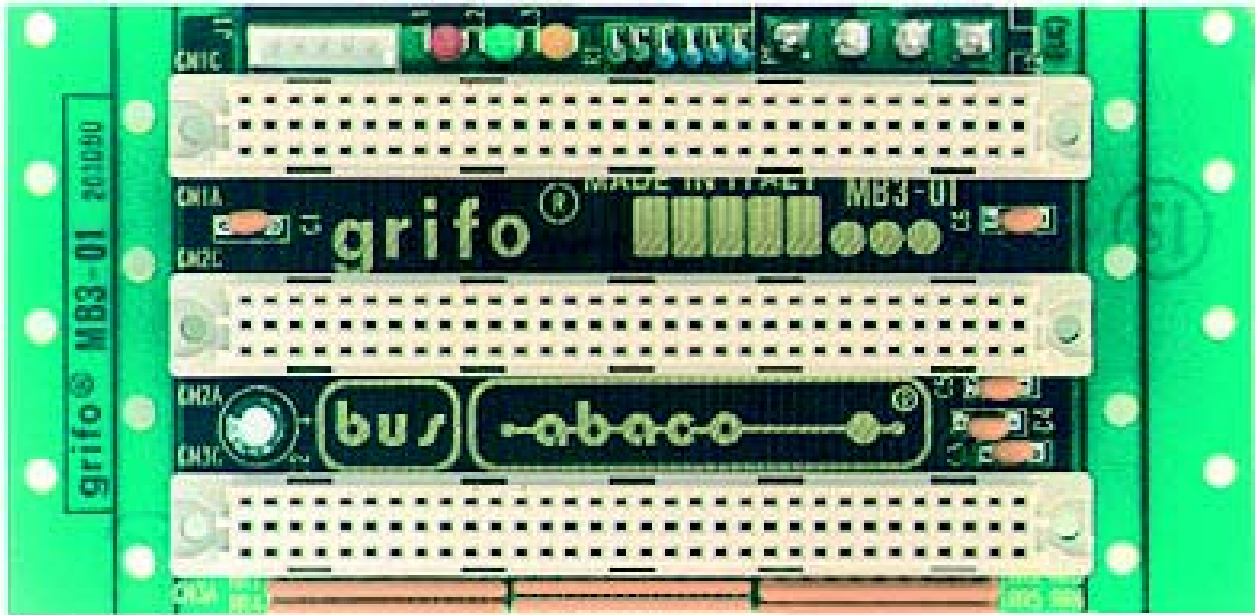

FIGURE 2: CARD PHOTO

INSTALLATION

In this chapter there are the information for a right installation and correct use of the card. The user can find the location and functions of each connectors and LEDs and some explanatory diagrams.

CONNECTIONS

The **MB3 01** module is provided respectively with 5 connectors that can be linkeded to control system cards or directly to the field, according to system requirements. In this paragraph there are connectors pin out, a short signals description (including the signals direction) and connectors location (please refer to figure 4).

Following figures show the frontal view of connectors; they can be easily recognized because they reproduce exactly the shape of the connectors and also thanks to the serigraph on the board.

J1 - REMOTE CONNECTION OF RESET KEY AND LEDS

J1 is a 5 pins, vertical, low profile, male connector, ptch 2.54 mm.

It allows to connect remotely a reset key and up to three LEDs that indicate the power supplies presence. For further information please see the specific paragraphs and the electric diagrams in the following pages.

Female connector can be made using the separated sets of pieces ordereable from **grifo**[®]: code **CS5 AUX** (5 pins female connector) and code **CSF Cable** (set of crimped cables, one meter long).

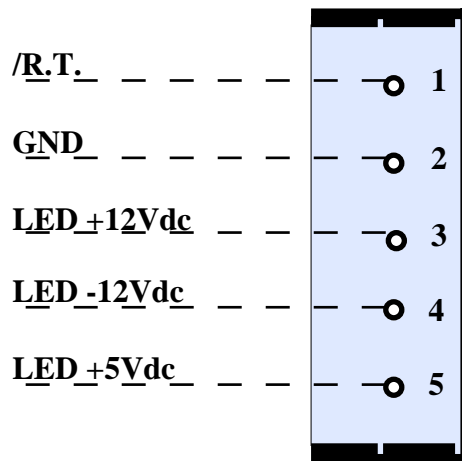

FIGURE 3: J1 - CONNECTOR FOR REMOTE RESET KEY AND LEDS

Signals description:

- /R.T.** = I - RESET key.
- GND** = - Ground.
- LED +12Vdc** = O - Anod of LED that signals the presence of +12 Vdc.
- LED -12Vdc** = O - Cathod of LED that signals the presence of -12 Vdc.
- LED +5Vdc** = O - Anod of LED that signals the presence of +5 Vdc.

As shown in figure 9, LEDs can be connected directly to mother board, which has its drop resistors.

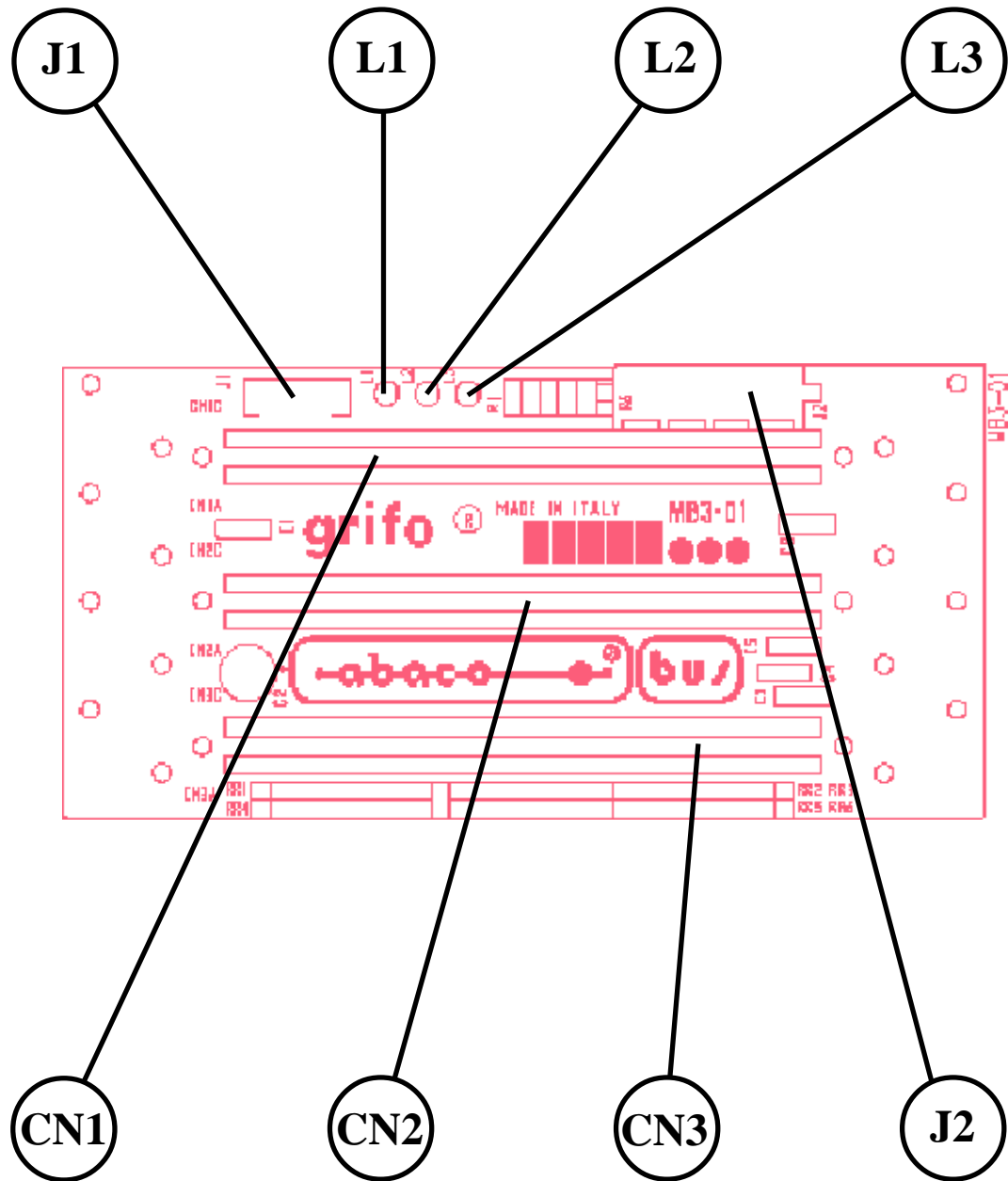

FIGURE 4: CONNECTORS AND LEDs LOCATION

J2 - POWER SUPPLY CONNECTOR

J2 is a 4pins AMP MATE N LOK connector, vertical, male, pitch 6.35 mm.

Any external power source, like for example a power supply, can provide standard supply voltages to **ABACO**® slots through J2. Pin out of this connector is standard, so replacing present mother board with another one provided with a greater number of slots is not a problem.

Female connector can be made using the kit orderable from **grifo**® with codes **CS4 POWER** (set of 4 pins plug containers) and **CSP Pins** (set of pins to crimp to wire and insert in the container) or, purchasing directly from AMP catalog, part numbers **350779-1** (connector plug AMPMATENLOK 4 pins) and **350536-1** (socket contacts to crimp).

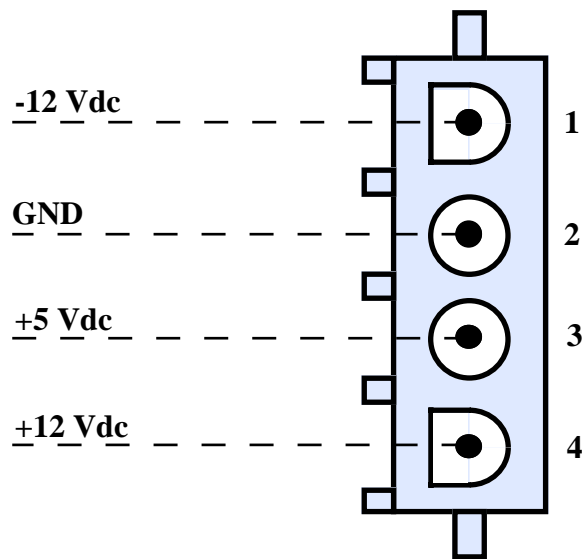

FIGURE 5: J2 - POWER SUPPLY CONNECTOR

Signals description:

+12Vdc	=	I - Supply voltage +12 Vdc for BUS ABACO ®.
-12Vdc	=	I - Supply voltage -12 Vdc for BUS ABACO ®.
+5Vdc	=	I - Supply voltage +5 Vdc for BUS ABACO ®.
GND	=	- Ground.

Please remember that only the boards to install can determine which supply voltages should be provided, in fact mother board does not require any supply, it just indicates presence of voltages. Also power to provide must be calculated summing the power required by the boards to install, considering that on board visualization requires additional 15 mA and eventual remote visualization would require another additional 15 mA.

Please remark also that **MB' 01** is provided with noise reduction filters on all the supply lines, made by tracks shielding and several capacitors.

These capacitors will have to be loaded during power on, this produces a peak of current that the generator must be able to provide.

TERMINATION RESISTORS

A very important feature of **MB3 01** mother boards is that all the signals of **ABACO® BUS** are provided with a termination resistor.

This feature minimizes the eventual effects due to signals that otherwise would remain floating and in the meantime it warrants the functionality and the perfect interfacing to all the **grifo®** industrial boards listing. Thanks to the termination resistors in fact, also boards provided with CMOS BUS interfaces can be connected, obtaining an overall reduction of the power consumption for the application system.

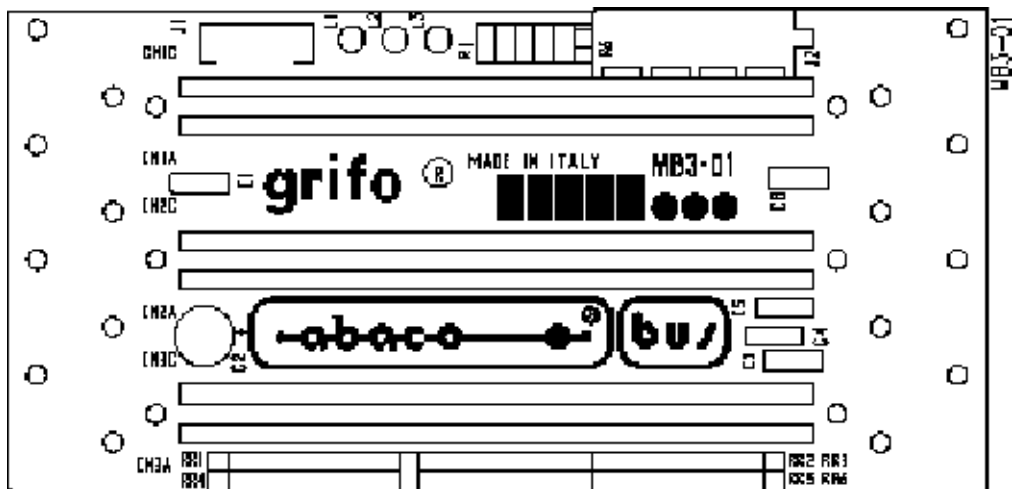

FIGURE 6: COMPONENTS MAP

CN1÷CN3 - ABACO® BUS CONNECTORS

CN1÷CN3 are 64 pins DIN 41612 A+C type C female connectors, to interface with the industrial **ABACO® BUS**.

Here follows the standard 8 bits and 16 bits **ABACO® BUS** pin-out.

Please remark that all the signals here described are TTL, except for the power supplies.

A 16 bit BUS	A 8 bit BUS	PIN	C 8 bit BUS	C 16 bit BUS
GND	GND	1	GND	GND
+5 Vdc	+5 Vdc	2	+5 Vdc	+5 Vdc
D0	D0	3	-	D8
D1	D1	4	-	D9
D2	D2	5	-	D10
D3	D3	6	/INT	/INT
D4	D4	7	/NMI	/NMI
D5	D5	8	/HALT	D11
D6	D6	9	/MREQ	/MREQ
D7	D7	10	/IORQ	/IORQ
A0	A0	11	/RD	/RDLDS
A1	A1	12	/WR	/WRLDS
A2	A2	13	/BUSAK	D12
A3	A3	14	/WAIT	/WAIT
A4	A4	15	/BUSRQ	D13
A5	A5	16	/RESET	/RESET
A6	A6	17	/M1	/IACK
A7	A7	18	/RFSH	D14
A8	A8	19	/MEMDIS	/MEMDIS
A9	A9	20	VDUSEL	A22
A10	A10	21	/IEI	D15
A11	A11	22	-	-
A12	A12	23	CLK	CLK
A13	A13	24	-	/RDUDS
A14	A14	25	-	/WRUDS
A15	A15	26	-	A21
A16	-	27	-	A20
A17	-	28	-	A19
A18	-	29	/R.T.	/R.T.
+12 Vdc	+12 Vdc	30	-12 Vdc	-12 Vdc
+5 Vdc	+5 Vdc	31	+5 Vdc	+5 Vdc
GND	GND	32	GND	GND

FIGURE 7: CN1÷CN3 - ABACO® BUS CONNECTORS

Signals description:

8 bits CPU

A0-A15	=	O	- Address BUS
D0-D7	=	I/O	- Data BUS
/INT	=	I	- Interrupt request
/NMI	=	I	- Non Maskable Interrupt
/HALT	=	O	- Halt state
/MREQ	=	O	- Memory Request
/IORQ	=	O	- Input Output Request
/RD	=	O	- Read cycle status
/WR	=	O	- Write cycle status
/BUSAK	=	O	- BUS Acknowledge
/WAIT	=	I	- Wait
/BUSRQ	=	I	- BUS Request
/RESET	=	O	- Reset
/M1	=	O	- Machine cycle one
/RFSH	=	O	- Refresh for dynamic RAM
/MEMDIS	=	I	- Memory Display
/VDUSEL	=	O	- VDU Selection
/IEI	=	I	- Interrupt Enable Input
CLK	=	O	- System clock
/R.T.	=	I	- Reset button
+5 Vdc	=	I	- Power supply at +5 Vdc
+12 Vdc	=	I	- Power supply at +12 Vdc
-12 Vdc	=	I	- Power supply at -12 Vdc
GND	=		- Ground signal

16 bits CPU

A16-A22	=	O	- Address BUS
D8-D15	=	I/O	- Data BUS
/RD UDS	=	O	- Read Upper Data Strobe
/WR UDS	=	O	- Write Upper Data Strobe
/IACK	=	O	- Interrupt Acknowledge
/RD LDS	=	O	- Read Lower Data Strobe
/WR LDS	=	O	- Write Lower Data Strobe

NOTE

Directionality indications as above stated are referred to a master (**GPC®**) board and have been kept untouched to avoid ambiguity in case of multi-boards systems.

ABACO® BUS is not multimaster. Please remark that only one CPU intelligent control board can be installed in the **ABACO®** BUS chain.

VISUAL SIGNALATIONS

MB3 01 module is provided with three LEDs for visual signalations as described here:

LED	COLOUR	DESCRIPTION
LD1	Red	When lit, indicates the presence of +5 Vdc power supply.
LD2	Green	When lit, indicates the presence of -12 Vdc power supply.
LD3	Yellow	When lit, indicates the presence of +12 Vdc power supply.

FIGURE 8: VISUAL SIGNALATIONS TABLE

The main purpose of these LEDs is to provide a visual indication of supply normalized voltages, making easier to verify the working status of the system. In addition, connector J1 allows to remote these signalations and install them, for example, on an indicator board, etc. LEDs can be connected directly from the boards, in fact this latter features also the drop resistors.

To easily locate the visual signalations, please refer to figure 4.

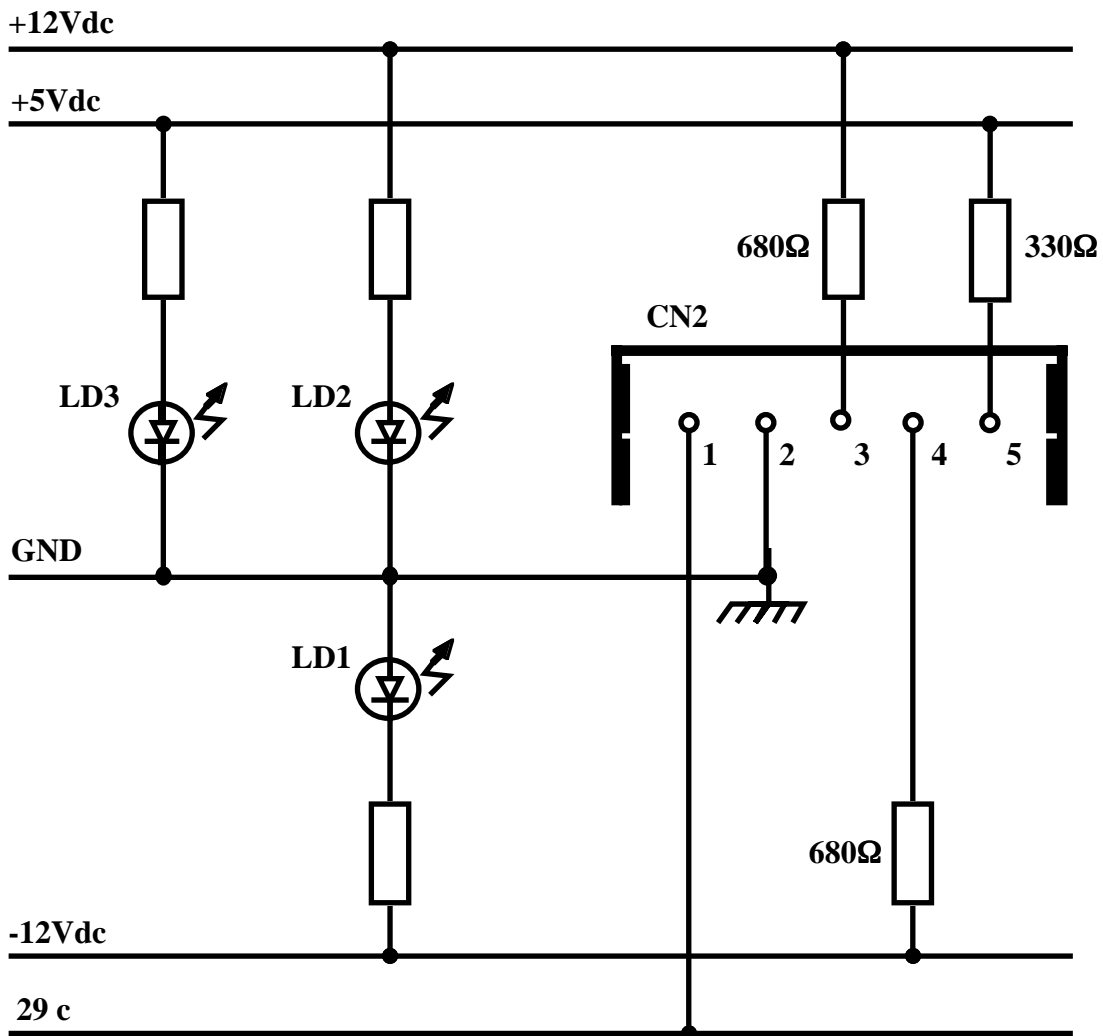

FIGURE 9: LEDs CONNECTION DIAGRAM

EXTERNAL CARDS

MB3 01 mother board can interface to most of **grifo**® industrial boards. Their main purpose is to perform a digital Input/Output interfacement between CPU (**GPC**®) cards in EUROCARD format installed on an electric rack provided with Ω rails and the external world.

Please remark that **ABACO**® BUS is not multimaster, so there must be only one **GPC**® card installed on the BUS.

Here is reported an illustrative list of cards capable to interact with **MB3 01** mother board with a short description of their features; for further information please request the specific documentation.

EXA 01

Extension Card **ABACO**®

Rigid extension for industrial BUS **Abaco**®. Keeps the card to examine out of the rack and connected; jumpers to dock the instrumentation and to segment the signals to be examined; LEDs to visualize power supply.

SPB 04-SPB 08

Switch Power BUS 4-8 slots

Motherboard featuring 4-8 slots of **ABACO**® industrial BUS; pitch 4 TE; standard power supply connectors; termination resistances; connector type F for **SPC xxx** supply ; holes for rack docking.

SBP 02-xx

Switch BLOCK Power xx version

Low cost switching power supply able to generate voltage from +5 to +40 Vdc and current up to 2.5 A; Input from 12 to 24 Vac; Connection for DIN C Type and Ω rails.

JMS 34

Jumbo Multifunction Support for Axis control

Generic peripheral axis control card. 3 optocoupled acquisition channels, with 16 bits bidirectional counter, for incremental encoder. 4 12bits ± 10 Vdc D/A channels. 8 Opto-in; 8 NPN Opto-output 40Vdc 500 mA. All I/O lines displayed with LEDs.

IPC 52

Intelligent Peripheral Controller, 24 analogic input

This intelligent peripheral card acquires 24 independent analogic input lines: 8 PT 100 or PT 1000 sensors, 8 J,K,S,T termocouples, 8 analog input ± 2 Vdc or $4 \div 20$ mA; 16 bits + sign A/D section; 0.1 °C resolution; 32K RAM for local data logging; buzzer; 16 TTL I/O lines; 5 or 8 conversion per second; facility of networking up to 127 IPC 52 cards using serial line. BUS interfacing or through RS 232, RS 422, RS 485 or current loop line. Only 5Vdc power supply.

GPC® 188F

General Purpose Controller 80C188

80C188 μ P 20MHz; 1 RS 232 line; 1 RS 232, RS 422-485 or Current Loop line; 24 TTL I/O lines; 1MEPROM or 512K FLASH; 1M RAM Lithium battery backed; 8K serial EEPROM; RTC; Watch Dog; 8 Dip switch; 3 Timer Counter; 8 13 bit A/D lines; Power failure; activity LEDs; single power supply +5Vdc.

GPC® 150

General Purpose Controller 84C15

Microprocessor Z80 at 16 MHz; implementation completely CMOS; 512K EPROM or FLASH; 512K SRAM; RTC; Back-Up through external Lithium battery; 4M serial FLASH; 1 serial line RS 232 plus 1 RS 232 or RS 422-485 or current loop; 40 I/O TTL; 2 timer/counter; 2 watch dog; dip switch; EEPROM; A/D converter with resolution 12 bit; activity LED.

GPC® 15R

General Purpose Controller 84C15

84C15 μ P, 10÷16 MHz; 1 RS 232 line; 1 RS 232 or RS 422-485 or C. L. line; 16÷24 TTL I/O lines; 16 Opto-in; 8 Relays; 4 Opto Coupled Timers Counters; 512K EPROM or FLASH; 512K RAM and RTC backed; 8K serial EEPROM; 8K Backed RAM modul; Buzzer; 1 Activity LED; Watch dog; 4÷12 readable DIPs; LCD Interface.

GPC® 15A

General Purpose Controller 84C15

Full CMOS card, 10÷20 MHz 84C15 CPU; 512K EPROM or FLASH; 128K RAM; 8K RAM and RTC backed; 8K serial EEPROM; 1 RS 232 line; 1 RS 232 line or RS 422-485 or Current Loop line; 32 or 40 TTL I/O lines; CTC; Watch dog; 2 Dip switches; Buzzer.

GPC® 550

General Purpose Controller 80C552

Microprocessor 80C552 at 22 MHz. 32K EPROM; 32 K SRAM; 32 K EEPROM or SRAM; RTC; serial EEPROM; 1 line RS 232 + 1 RS 232 or RS 422-485 or current loop; 40 I/O TTL; 2 PWM lines; 16 bits timer/counter; watch dog; dip switch; 8 A/D lines with resolution 10 bit; interface for BUS **ABACO®**; galvanucally isolated CAN serial line. Unique power supply +5 Vdc; EUROCARD format.

LDA 01

Low cost Digital to Analog converter 12 bits

2 D/A converter resolution 12 bit; 8 open collector da 45 Vdc transistor outputs, 500 mA, optocoupled; data view by LED; selectable analog output: 0÷5, 0÷10, ± 5 and ± 10 Vdc; gain and offset regulation; 8 or 16 bit BUS; extended addressing.

LAD 12

Low cost Analog to Digital conv. 12 bits

Dual slope 16 lines A/D converter; 12 bit + sign conversion; 12,5 conversions per second rate; range $\pm 2,048$ Vdc or 0÷20 mA; automatic running mode; 1 LED, 2 TTL input lines; 8 bit Bus; front panel.

LAD 15

Low cost Analog to Digital conv. 15 bits

Dual slope 16 lines A/D converter; 15 bit + sign conversion; 2,5 conversions per second rate; range $\pm 3,2768$ Vdc or 0÷20 mA; automatic running mode; 2 LEDs; 2 TTL input lines; 8 bit Bus; front panel.

CI/O R16

16 Coupled Input Output Relé

16 optocoupled input with π -filter; input voltage 24 Vdc. 16 micro-relays 1 A with disturb suppression by MOV 24 Vac. I/O visualized through LEDs; 8 bit BUS; standard addressing.

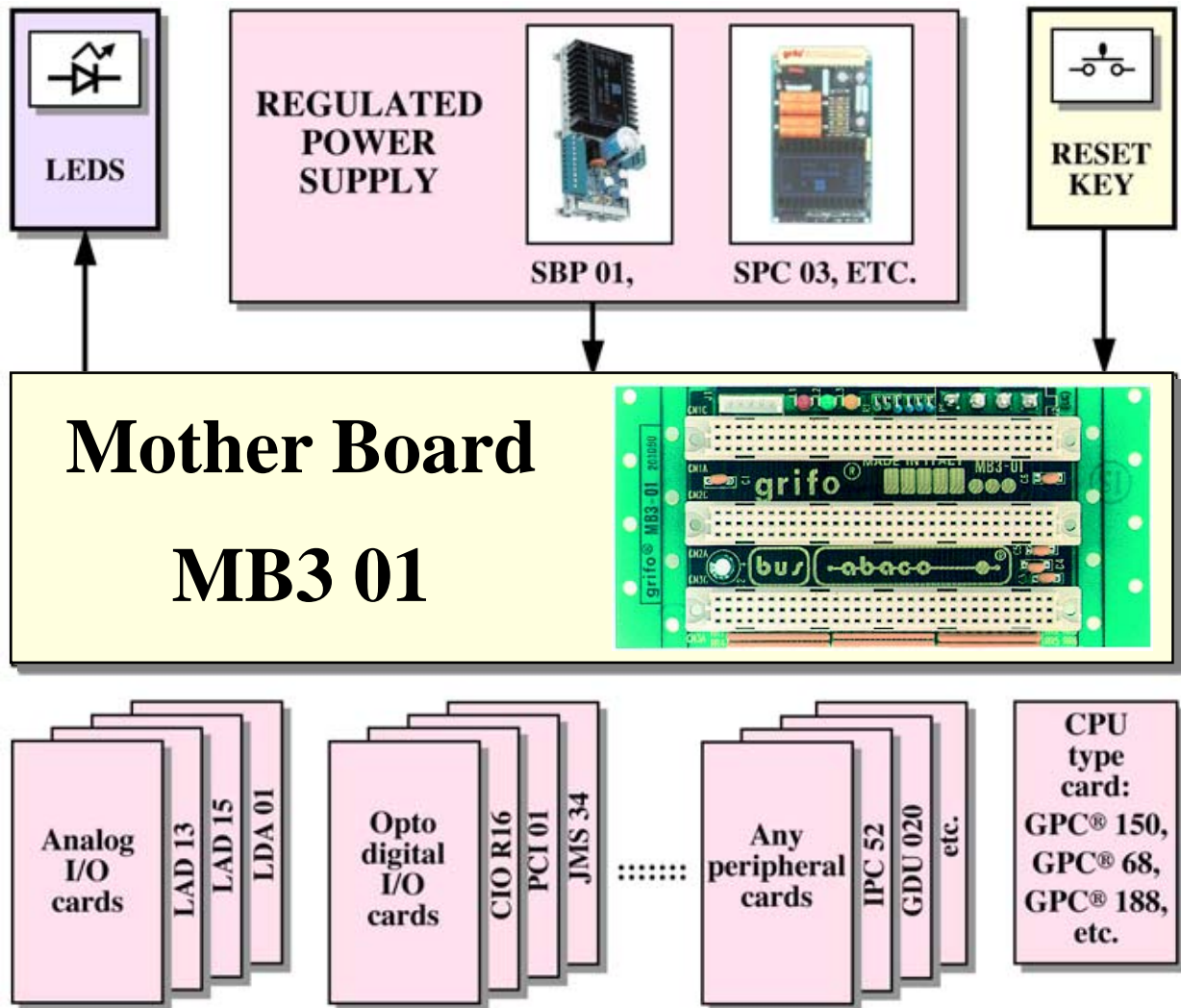

FIGURE 10: POSSIBLE CONNECTIONS DIAGRAM

PCI 01

32 Peripheral Coupled Input

16 optocoupled input with π -filter; input voltage 24 Vdc; I/O visualized through LEDs; 8 or 16 bit BUS; standard addressing.

PIO 01

Peripheral Input/Output

96 I/O TTL signals grouped in 12 ports 8 bit wide; 6 standard 20 pins I/O connectors; 4 PPI 82C55 drive the signals; Watch dog with intervention time and modality selectable.

UCC 08

UART Communication Card 8 linee

8 independent serial lines RS 232 or RS 422-485. Each line: 4 chars buffer; asynchronous communication; Baud rate (50 up to 38.4K baud), parity, stop bit and data bit are software selectable; 3 Dip Switch; 8 bit BUS; extended addressing.

SPC 03.5S

Switch Power Card +5 Vdc

Europe format switching power supply capable to provide +5 Vdc to a load of 4 A; input voltage 12÷24 Vac; power-failure; connector for back-up battery; standard connector for mother board **SPB 0x**.

SPC 512

Switch Power Card +5 Vdc +12 Vdc

Europe format switching power supply capable to provide +5 Vdc 5A and +12 Vdc 2.5 A; input voltage 12÷24 Vac; power-failure; connector for back-up battery; standard connector for mother board **SPB 0x**.

APPENDIX A: ALPHABETICAL INDEX

SYMBOLS**+12VDC 8****+5VDC 8****-12VDC 8****/R.T. 6****A****ABACO® BUS 4, 10****C****CONNECTORS 4****CN1÷CN3 10****J1 6****J2 8****D****DEVICES 4****E****EXTERNAL CARDS 13****L****LEDS 6, 12****M****MOUNTING 4****P****POWER SUPPLY 4, 8****R****RELATIVE HUMIDITY 4****RESET 6****RESISTORS 4, 9****S****SIZE 4****SLOTS PITCH 4**

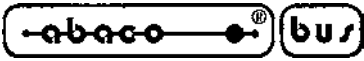

grifo®

ITALIAN TECHNOLOGY

T

TEMPERATURE RANGE 4

TERMINATION 4, 9

W

WEIGHT 4

