

SBP 05 SBP 10

Switching Block Power 5 A
Switching Block Power 10 A

TECHNICAL MANUAL

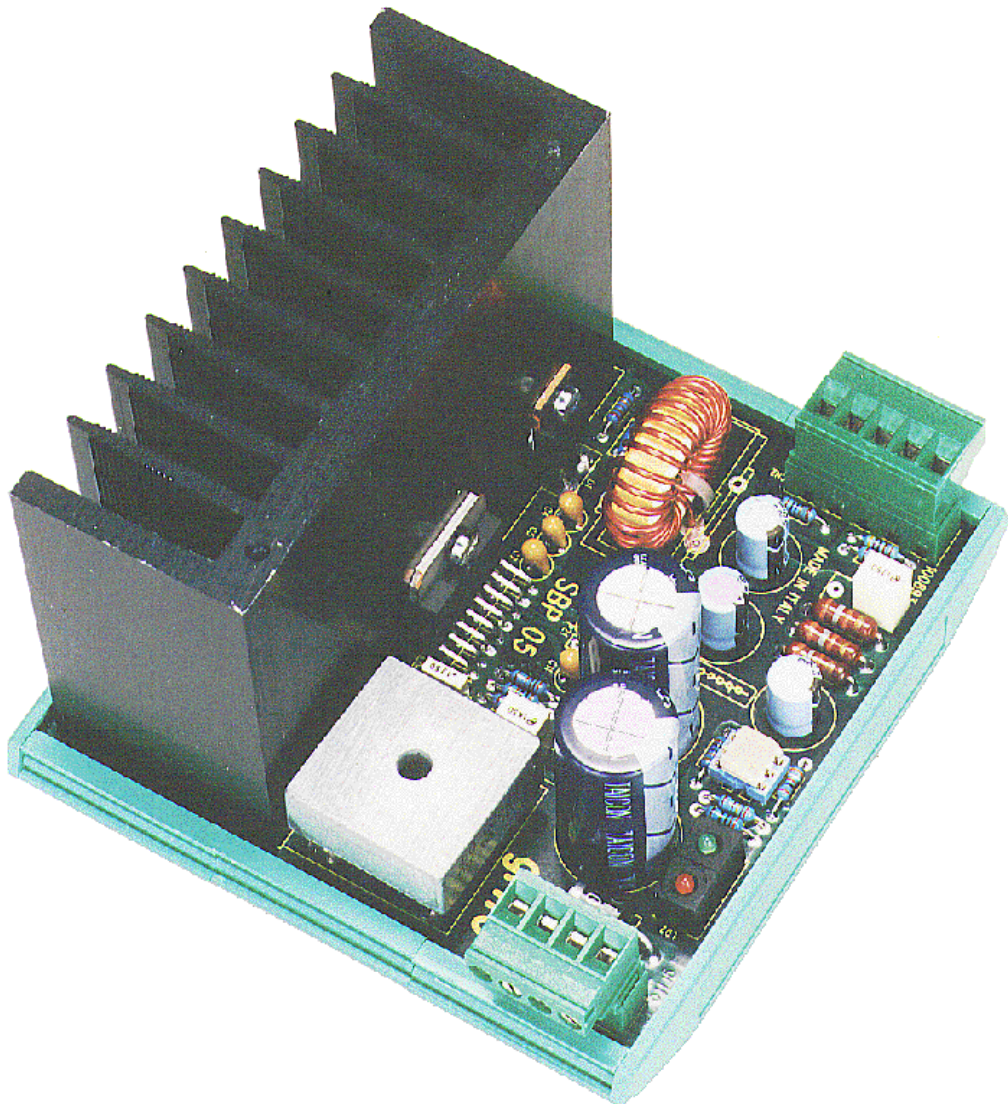

grifo[®]
ITALIAN TECHNOLOGY

Via dell' Artigiano, 8/6
40016 San Giorgio di Piano
(Bologna) ITALY
E-mail: grifo@grifo.it



<http://www.grifo.it> <http://www.grifo.com>
Tel. +39 051 892.052 (a. r.) FAX: +39 051 893.661

SBP 05, SBP 10 Edition 5.00 Rel. 19 March 2002

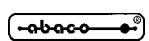
, GPC[®], grifo[®], are trade marks of grifo[®]

SBP 05

SBP 10

Switching Block Power 5 A
Switching Block Power 10 A

TECHNICAL MANUAL

BLOCK format, measuring **120x110x100 mm**, complete of plastic container for omega rails DIN 247277-1 and 247277-3; electrical connection by two comfortable **screw terminal**, quick release, 4 and 5 pins connectors; two **LEDs** which indicate the presence of the generated voltage and possible **failure**; noises reduction **filters** on the inputs and outputs; huge **heat sink** that ensures the correct functionality even with heavy external environment conditions; **protection** on over temperature, insufficient input voltage, over load and short circuit; average efficiency of **80%**; input for auxiliary voltage from a 24 Vdc battery for **UPS** function; required voltage variable in the range 10÷33 Vac or 13÷46 Vdc according to the model; generated voltages: variable according with selected model (see following table):

Model	Output voltage - current
SBP 05	5 Vdc - 5 A
SBP 05.12	12 Vdc - 5 A
SBP 05.15	15 Vdc - 5 A
SBP 05.24	24 Vdc - 5 A
SBP 10	5 Vdc - 10 A
SBP 10.12	12 Vdc - 10 A
SBP 10.15	15 Vdc - 10 A
SBP 10.24	24 Vdc - 10 A

grifo[®]

ITALIAN TECHNOLOGY

Via dell' Artigiano, 8/6
40016 San Giorgio di Piano
(Bologna) ITALY

E-mail: grifo@grifo.it

<http://www.grifo.it>

<http://www.grifo.com>

Tel. +39 051 892.052 (a. r.) FAX: +39 051 893.661

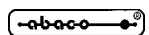

SBP 05, SBP 10 Edition 5.00 *Rel. 19 March 2002*

, GPC[®], grifo[®], are trade marks of grifo[®]

DOCUMENTATION COPYRIGHT BY grifo®, ALL RIGHTS RESERVED

No part of this document may be reproduced, transmitted, transcribed, stored in a retrieval system, or translated into any language or computer language, in any form or by any means, either electronic, mechanical, magnetic, optical, chemical, manual, or otherwise, without the prior written consent of **grifo®**.

IMPORTANT

Although all the information contained herein have been carefully verified, **grifo®** assumes no responsibility for errors that might appear in this document, or for damage to things or persons resulting from technical errors, omission and improper use of this manual and of the related software and hardware.

grifo® reserves the right to change the contents and form of this document, as well as the features and specification of its products at any time, without prior notice, to obtain always the best product.

For specific informations on the components mounted on the card, please refer to the Data Book of the builder or second sources.

SYMBOLS DESCRIPTION

In the manual could appear the following symbols:



Attention: Generic danger



Attention: High voltage

Trade Marks

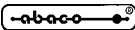
 , GPC®, **grifo®** : are trade marks of **grifo®**.

Other Product and Company names listed, are trade marks of their respective companies.

GENERAL INDEX

INTRODUCTION	1
CARD VERSION	1
GENERAL FEATURES	2
RECTIFIER SECTION	4
SWITCHING REGULATOR	4
OUTPUT SECTION AND FILTERS	6
TECHNICAL FEATURES	8
GENERAL FEATURES	8
PHYSICAL FEATURES	8
ELECTRIC FEATURES OF SBP 05	8
ELECTRIC FEATURES OF SBP 10	9
INSTALLATION	10
CONNECTIONS	10
CN1 - INPUT VOLTAGE CONNECTOR	10
CN2 - OUTPUT VOLTAGE CONNECTOR	11
OUTPUT VOLTAGE LOAD SENSING	11
VISUAL FEEDBACK	12
PROTECTIONS	12
/RESET AND POWER FAILURE	13
INPUT VOLTAGES AND UPS	14
POWER PROVIDED	14
EXTERNAL DEVICES FOR SBP 05 AND SBP 10	15
BIBLIOGRAPHY	18
APPENDIX A: ALPHABETICAL INDEX	A-1

FIGURE INDEX

FIGURE 1: CARD PHOTO OF SBP 05	3
FIGURE 2: BLOCK DIAGRAM	5
FIGURE 3: COMPONENTS MAP	6
FIGURE 4: PHOTO OF SBP 10	7
FIGURE 5: CN1 - INPUT VOLTAGE CONNECTOR	10
FIGURE 6: CN2 - OUTPUT VOLTAGE CONNECTOR	11
FIGURE 7: VISUAL FEEDBACK TABLE	12
FIGURE 8: LEDs, CONNECTORS, VOLTAGES, ETC. LOCATION	13
FIGURE 9: POWER FOR EACH MODEL TABLE	14
FIGURE 10: POSSIBLE CONNECTIONS DIAGRAM	17



INTRODUCTION

The use of these devices has turned - IN EXCLUSIVE WAY - to specialized personnel.

The purpose of this handbook is to give the necessary information to the cognizant and sure use of the products. They are the result of a continual and systematic elaboration of data and technical tests saved and validated from the manufacturer, related to the inside modes of certainty and quality of the information.

The reported data are destined- IN EXCLUSIVE WAY- to specialized users, that can interact with the devices in safety conditions for the persons, for the machine and for the environment, impersonating an elementary diagnostic of breakdowns and of malfunction conditions by performing simple functional verify operations , in the height respect of the actual safety and health norms.

The informations for the installation, the assemblage, the dismantlement, the handling, the adjustment, the reparation and the contingent accessories, devices etc. installation are destined - and then executable - always and in exclusive way from specialized warned and educated personnel, or directly from the TECHNICAL AUTHORIZED ASSISTANCE, in the height respect of the manufacturer recommendations and the actual safety and health norms.

The devices can't be used outside a box. The user must always insert the cards in a container that respect the actual safety normative. The protection of this container is not threshold to the only atmospheric agents, but specially to mechanic, electric, magnetic, etc. ones.

To be on good terms with the products, is necessary guarantee legibility and conservation of the manual, also for future references. In case of deterioration or more easily for technical updates, consult the AUTHORIZED TECHNICAL ASSISTANCE directly.

To prevent problems during card utilization, it is a good practice to read carefully all the informations of this manual. After this reading, the user can use the general index and the alphabetical index, respectly at the begining and at the end of the manual, to find information in a faster and more easy way.

CARD VERSION

The present handbook is reported to the **SBP 05** and **SBP 10** card release **010194** and later. The validity of the bring informations is subordinate to the number of the card release. The user must always verify the correct correspondence among the two denotations. On the card the release number is present in more points both board printed diagram (serigraph) and printed circuit (for example near five pins connector on the component side or under heat sink on the solder side).

GENERAL FEATURES

The **SBP 05** and **SBP 10** modules are complete, low cost, switching power supplies with extremely reduced dimension, that can be used for medium and large loads.

They are provided in a plastic container for a direct mounting on omega rails where it has a front side of only 110 mm, while two quick release screw terminal connectors allow the connections to external circuits. These features simplify and reduce the required time for mounting, installation, replacement and connection of the same card.

The modules, to respect the security norms, provide for a low power supply input which can be alternate or direct; the wide range of this input yields the use of **SBP 05** and **SBP 10** in all the industrial electric panels, by using their standard voltages. There is also an auxiliary input coming from an external battery; in this case, **SBP 05/10** works like an **UPS** (Uninterruptible Power Supply), assuring power to the load, with no discontinuity, even without external mains voltage.

Two **LEDs** inform about the correct working of the power supply. One of them indicates the **failure** and it lights whenever each anomalous condition (over load, insufficient input voltage, high temperature, etc.) cause an interruption of generated power supply.

Proper **heat sink** ensures the 5 or 10 A output current on the connected load, even when the power supply works in external hostile surroundings.

The **SBP 05** and **SBP 10** are available in 4 different models that have different generated voltages:

Model	Output voltage - current	Input voltage
SBP 05	5 Vdc - 5 A	10÷33 Vac or 13÷46 Vdc
SBP 05.12	12 Vdc - 5 A	12÷33 Vac or 17÷46 Vdc
SBP 05.15	15 Vdc - 5 A	14÷33 Vac or 20÷46 Vdc
SBP 05.24	24 Vdc - 5 A	22÷33 Vac or 31÷46 Vdc
SBP 10	5 Vdc - 10 A	10÷33 Vac or 13÷46 Vdc
SBP 10.12	12 Vdc - 10 A	12÷33 Vac or 17÷46 Vdc
SBP 10.15	15 Vdc - 10 A	14÷33 Vac or 20÷46 Vdc
SBP 10.24	24 Vdc - 10 A	22÷33 Vac or 31÷46 Vdc

- BLOCK format, measuring **120x110x100 mm**, complete of plastic container for omega rails DIN 247277-1 and 247277-3
- Electrical connection by two comfortable **screw terminal**, quick release, 4 and 5 pins connectors
- Two **LEDs** which indicate the presence of the generated voltage and possible **failure**
- Noises reduction **filters** on the inputs and outputs
- Huge **heat sink** that ensures the correct functionality even with heavy external environment conditions
- Protection on over temperature, insufficient input voltage, overload and short circuit
- Average efficiency of **80%**
- Input for auxiliary voltage from a 24 Vdc battery, for **UPS** function
- Required voltage: variable according with selected model (see previous table)
- Generated voltages: variable according with selected model (see previous table)

Here follows a description of the board's functional blocks, with an indication of the operations performed by each one. To easily locate these blocks and verify their connections please refer to figure 2.

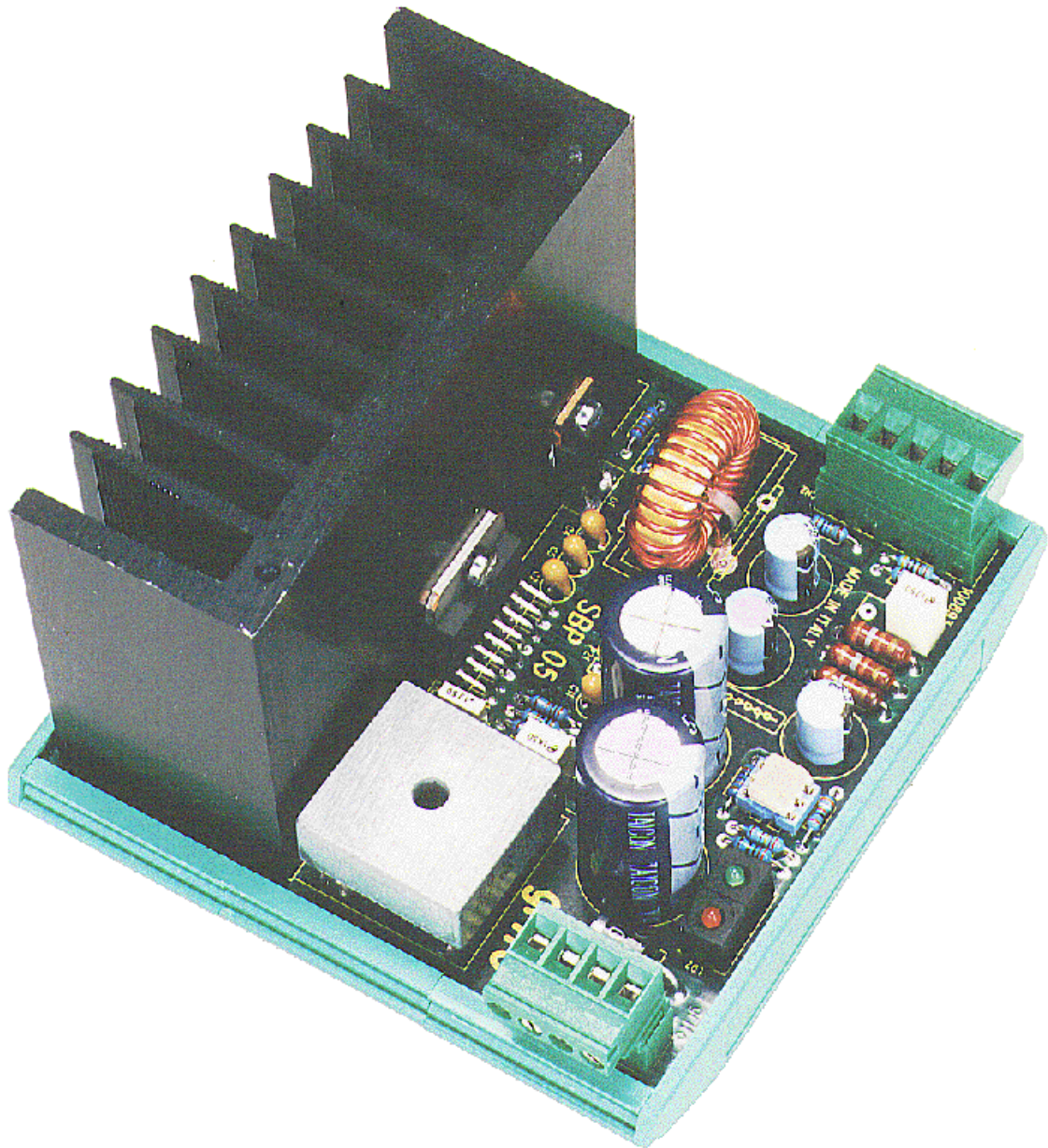

FIGURE 1: CARD PHOTO OF SBP 05

RECTIFIER SECTION

AC voltage in input to **SBP 05/10** is rectified by the specific rectifying section that generates a DC voltage for the switching power supply. Rectifying section is made of a simple bridge rectifier with capacitors that assure a DC voltage erogation in all the operating conditions of the power supply. Components are selected to reduce the value of ripple on the switching input whatever input voltage or output load is present. Rectifier section is always present but, as indicated in the block diagram, is used only in part if a DC voltage is provided as input. In such condition the bridge rectifier is not used and the input voltage is just filtered by the capacitors.

The presence of two different inputs for AC voltage and DC voltage allows the possibility to use the power supply as an UPS (connected, for example, to a battery) and provides the possibility to have output voltage referred to the same potential as input voltage.

Function of rectifier section does not change according to the model but physically it changes; in fact the bridge rectifier on **SBP 10** is mounted directly on the switching supply heat sink to allow sufficient heat dissipation.

SWITCHING REGULATOR

SBP 05 and **SBP 10** power supplies are based on an efficient switching regulator that performs the task to keep the output voltage under control and limit the output current. The main component of this section is the **L4970** power regulator manufactured by SGS. These modules have been designed specifically to build industrial power supplies of middle-high power with best price/performance rate and a good reliability, once matched to some external components. The overall features of switching regulation section are:

- soft start after a power on
- high efficiency, up to 80%
- protection against overcurrent or output short circuit
- protection against overheat
- protection against undervoltage in input
- switching frequency up to 220 KHz
- 0 to 90% duty cycle
- step down regulation
- automatic compensation of voltage drop due to connection cables
- generation of /RESET signal for power failure
- huge heatsink

Also in this section components have been selected to reach maximum efficiency and warrant anyway the maximum output current 5 or 10 A for the selected output voltage.

Some components of the regulation section may vary according to the model selected, so the output voltage selection cannot be made by the customer but must be specified in the order.

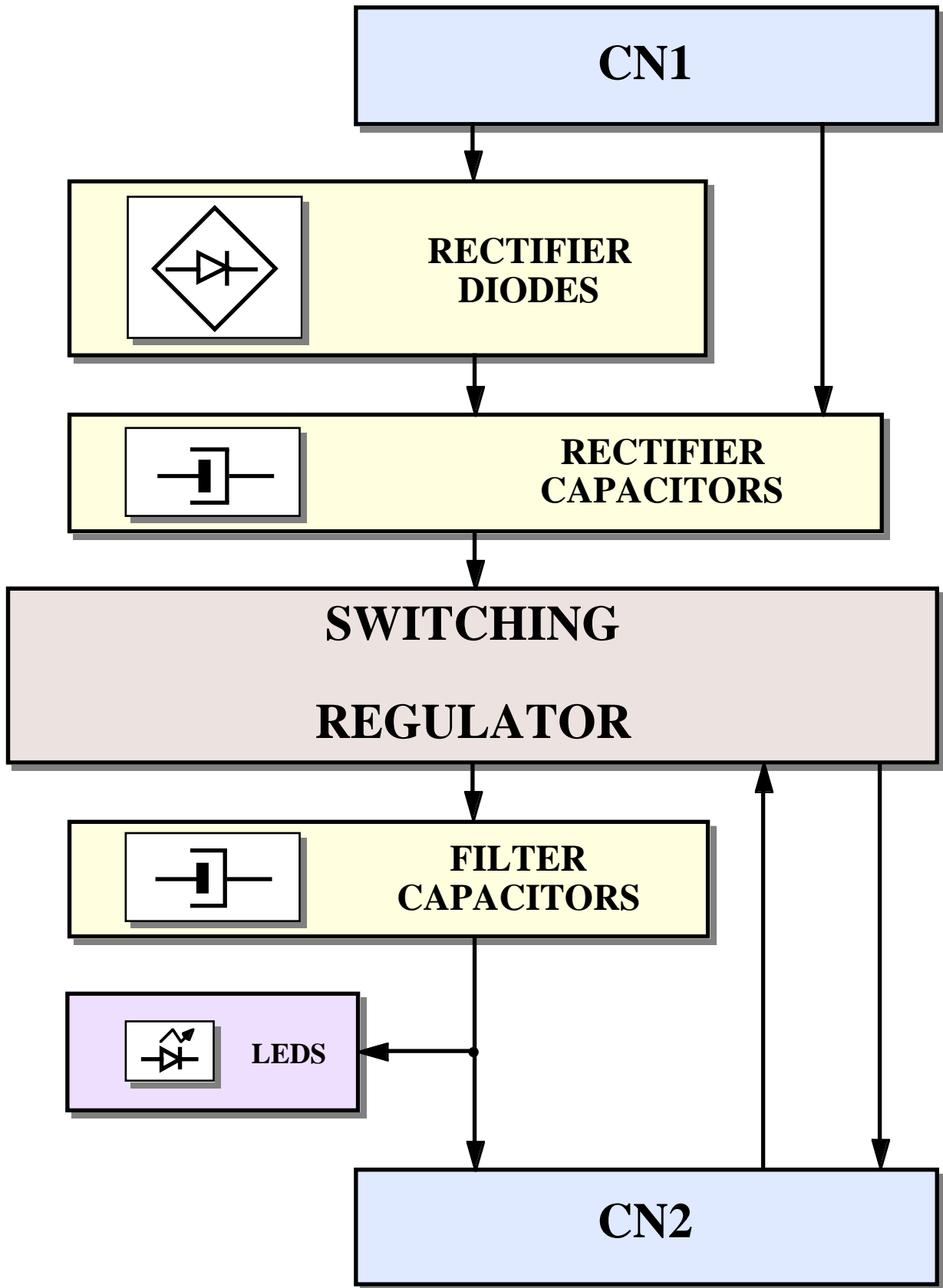

FIGURE 2: BLOCK DIAGRAM

OUTPUT SECTION AND FILTERS

Output section of **SBP 05/10** simply filters the stabilized voltages generated by the switching regulator through specific capacitors (for high and low frequencies) and visualizes the power supply status by two specific status LEDs. Components of this section vary according to the model selected and, as usual, all components have been selected to assure stability of output voltage under any operating condition.

Another feature of output section is a circuitry to warrant a minimum load on output terminals, to avoid instabilities that may appear in case no external load is connected.

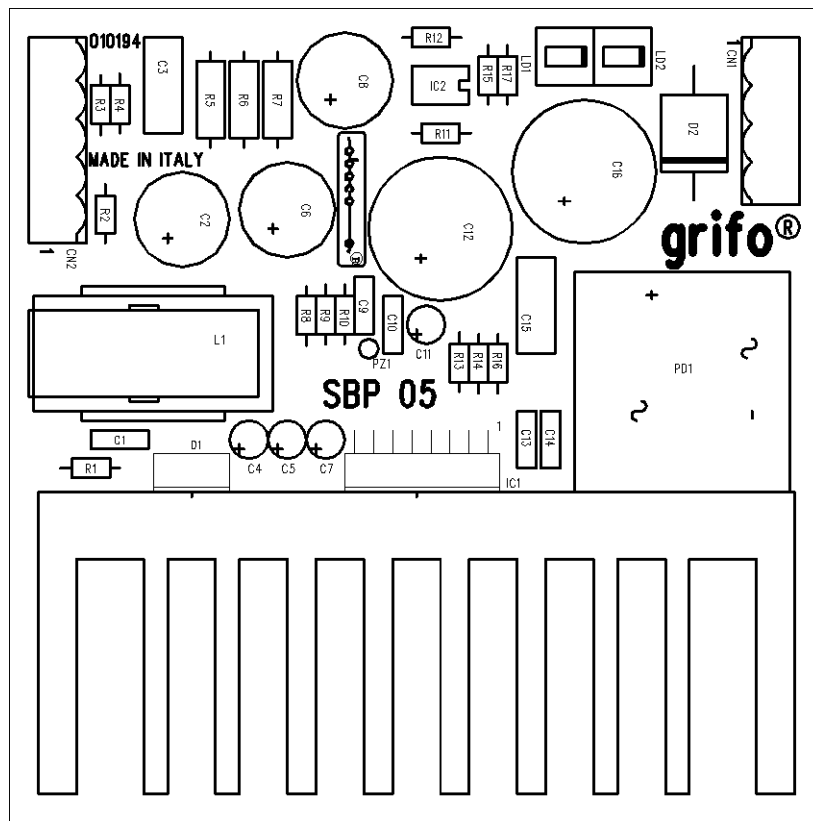

FIGURE 3: COMPONENTS MAP

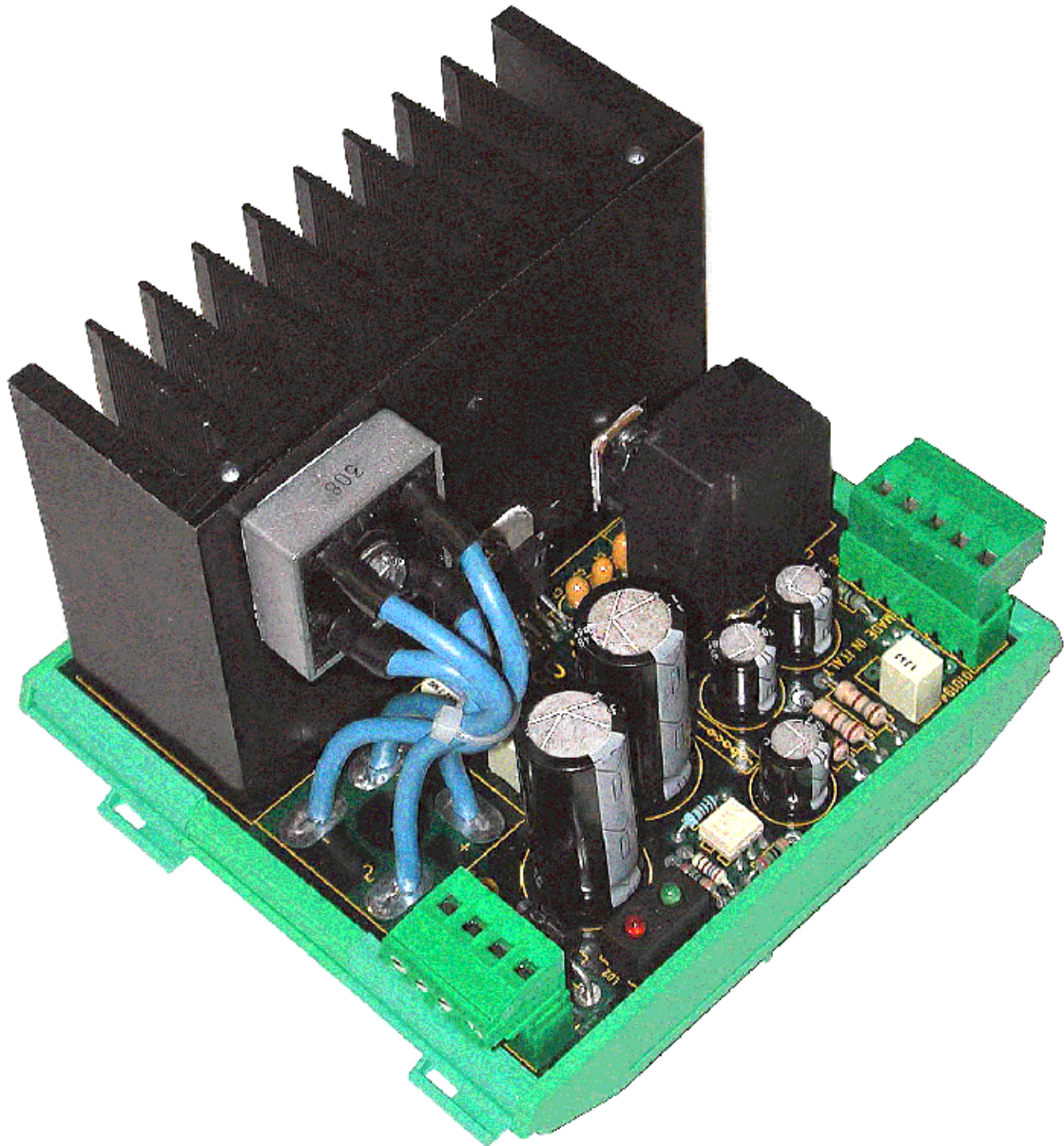

FIGURE 4: PHOTO OF SBP 10

TECHNICAL FEATURES

GENERAL FEATURES

Switching Frequency:	220 KHz
Average efficiency:	80%
Overheat protection:	150 °C, disables output and recovers automatically
Overload protection:	11 A, disables output and recovers automatically
Overload protection:	12 V, disables output and recovers automatically
Visualization:	two status LEDs
Reset signal duration:	10 msec minimum
Input voltage frequency:	50÷60 Hz

PHYSICAL FEATURES

Size:	120 x 110 x 100 mm
Weight:	590 g
Mounting:	Ω rails, DIN 247277-1 and 247277-3
Connectors:	CN1: 4 pins quick release screw terminal connector CN2: 5 pins quick release screw terminal connector
Temperature range:	0÷50 °C
Relative humidity:	20%÷90% (without condense)

ELECTRIC FEATURES OF SBP 05

Input voltages:	SBP 05 = 10÷33 Vac or 13÷46 Vdc
	SBP 05.12 = 12÷33 Vac or 17÷46 Vdc
	SBP 05.15 = 14÷33 Vac or 20÷46 Vdc
	SBP 05.24 = 22÷33 Vac or 31÷46 Vdc

Output voltages:

SBP 05 = 5 Vdc
SBP 05.12 = 12 Vdc
SBP 05.15 = 15 Vdc
SBP 05.24 = 24 Vdc

Output current: 5 A (referred to a 20° C environmental temperature)

ELECTRIC FEATURES OF SBP 10

Input voltages:

SBP 10 = 10÷33 Vac or 13÷46 Vdc
SBP 10.12 = 12÷33 Vac or 17÷46 Vdc
SBP 10.15 = 14÷33 Vac or 20÷46 Vdc
SBP 10.24 = 22÷33 Vac or 31÷46 Vdc

Output voltages:

SBP 10 = 5 Vdc
SBP 10.12 = 12 Vdc
SBP 10.15 = 15 Vdc
SBP 10.24 = 24 Vdc

Output current: 10 A (referred to a 20° C environmental temperature)

INSTALLATION

In this chapter there are the information for a right installation and correct use of the card. The user can find the location and functions of each connector and LEDs and some explanatory diagrams to improve operating conditions etc..

CONNECTIONS

The **SBP 05/10** power supplies have 2 connectors that can be linkeded to other devices or directly to the field, according to system requirements. In this paragraph there are connectors pin out and a short signals description (including the signals direction). To easily locate the connectors please refer to figure 8. Connectors view are reported to the external side of power supply and are easily recognizable through their shape and serigraph.

Quick release connectors ease cabling phase, even with thick cables, and allows a faster (eventual) replacement of the whole power supply in case of damage or maintenance.

CN1 - INPUT VOLTAGE CONNECTOR

CN1 is a 4 pins quick release screw terminal connector 5 mm pitch.

Through CN1 any kind of external generator (like a transformer, a battery, another power supply, etc.) can provide AC or DC input voltage to **SBP 05/10**.

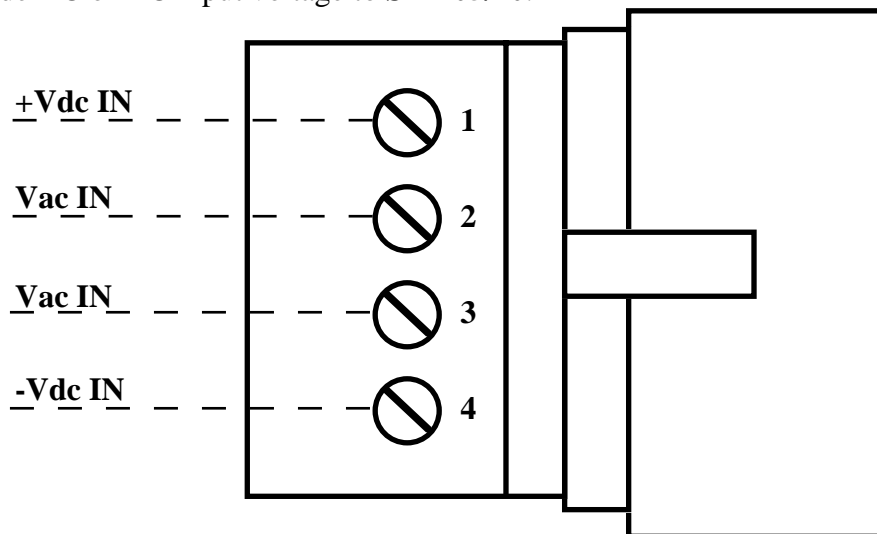

FIGURE 5: CN1 - INPUT VOLTAGE CONNECTOR

Signals description:

Vac IN	=	I	- AC input voltage lines
+Vdc IN	=	I	- Positive terminal of DC input voltage
-Vdc IN	=		- Negative terminal of DC input voltage

Value of input voltage varies in a wide range as described in the previous paragraph “ELECTRIC FEATURES”. Power of input signal must, of course, be enough to provide the required power to output signal as described in the successive paragraph “POWER PROVIDED”.

CN2 - OUTPUT VOLTAGE CONNECTOR

CN2 is a 5 pins screw terminal connector, 5 mm pitch.

CN2 allows to fetch the regulated output voltage to connect it to the external device to supply and the /RESET signal, to indicate whether output voltage is valid or not.

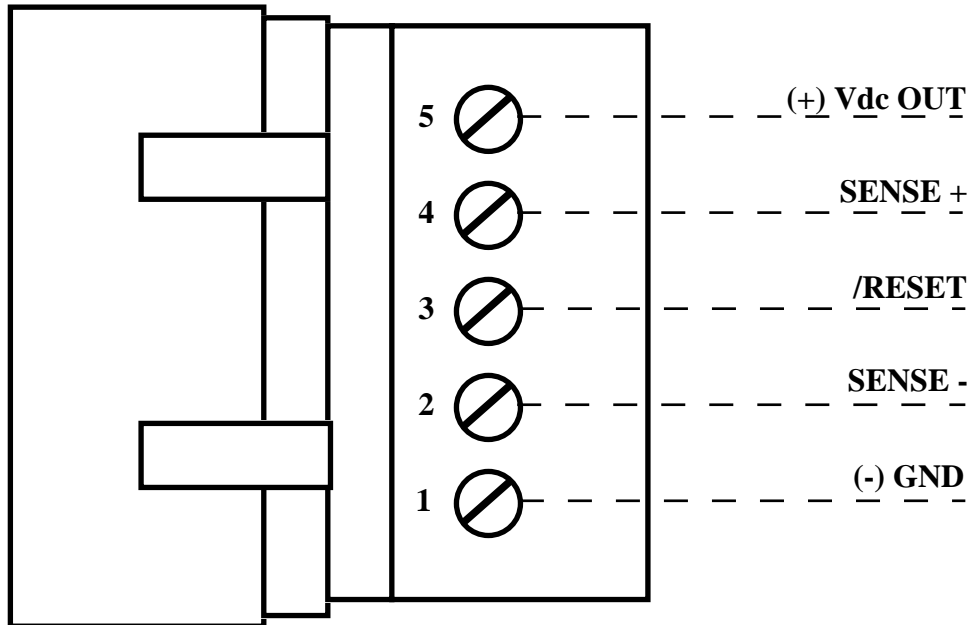

FIGURE 6: CN2 - OUTPUT VOLTAGE CONNECTOR

Signals description:

(+) Vdc OUT	=	O	- Positive terminal of regulated output voltage
(-) GND	=	-	Negative terminal of regulated output voltage
SENSE+	=	I	Positive terminal of sensing signal
SENSE-	=	I	Negative terminal of sensing signal
/RESET	=	O	Valid output voltage signal, in TTL

Value of output voltage varies in a wide range as described in the previous paragraph “ELECTRIC FEATURES”.

OUTPUT VOLTAGE LOAD SENSING

The sensing signals SENSE+ and SENSE- of CN2 must be connected respectively to signals (+) Vdc OUT and (-) GND directly on the load supplied that is on the farthest point from **SBP 05/10**. This feature allows the power supply to compensate autonomously the eventual voltage drop across the connection cables that carry the regulated tension to the load. This connection must be always performed: should this connection be uncomfortable or useless it is possible simply to short circuit pin 1 to pin 2 and pin 4 to pin 5 directly on CN2 screw terminal connector. Figure 8 shows the suggested connection for sensing signals.

VISUAL FEEDBACK

SBP 05/10 is provided with two LEDs to signal status condition, as described in the following table:

LED	COLOUR	DESCRIPTION
LD1	Green	When lit, indicates the presence of regulated output voltage.
LD2	Red	When lit, indicated the intervent of one of the switching supply protections (overload, overheat, short circuit, etc.).

FIGURE 7: VISUAL FEEDBACK TABLE

The main purpose of this LED is to give a visual indication of power supply status, making easier the operations of system working verify.

The LEDs allow, for example, to check:

- Input black out	->	LD1 OFF	LD2 OFF
- Switchin supply protection intervent	->	LD1 OFF	LD2 ON
- All OK	->	LD1 ON	LD2 OFF

To easily locate the LEDs on the board, please refer to figure 8.

PROTECTIONS

Modules **SBP 05/10** feature the typical protections that allow to save them against improper uses and contemporarily assure that the power supply remains in the range of nominal working values. In detail the power supply is provided with 4 different protections:

Overheat	Switching regulation section keeps under control its own working temperature so when this latter exceeds 150 °C it disables the output voltage to allow the temperature to decrease. Output is automatically restored when the temperature value get lower than hysteresis threshold, to prevent instable output conditions.
Overload	Switching reguation section keeps under control output current on CN2 so when current exceeds 11 A it disables the output voltage. After this, current is automatically restored softly. Soft start delay assures a limitation on output current in case the overload condition is still present.
Short circuit	Considered as overlaod condition.
Under Voltage in input	Switching regulation section keeps under control input voltage on CN1 so when this goes under 12 Vdc it disables the output voltage. Output is automatically restored when input voltage exceeds the 1 Vdc hysteresis threshold, to prevent instable output conditions.

After protection intervent, output voltage restore is always performed gradually (soft start), with gradual power increase.

It is always a good idea to consider to put an opportunely dimensioned protection fuse on input voltage, both AC and DC, to keep safe the power source.

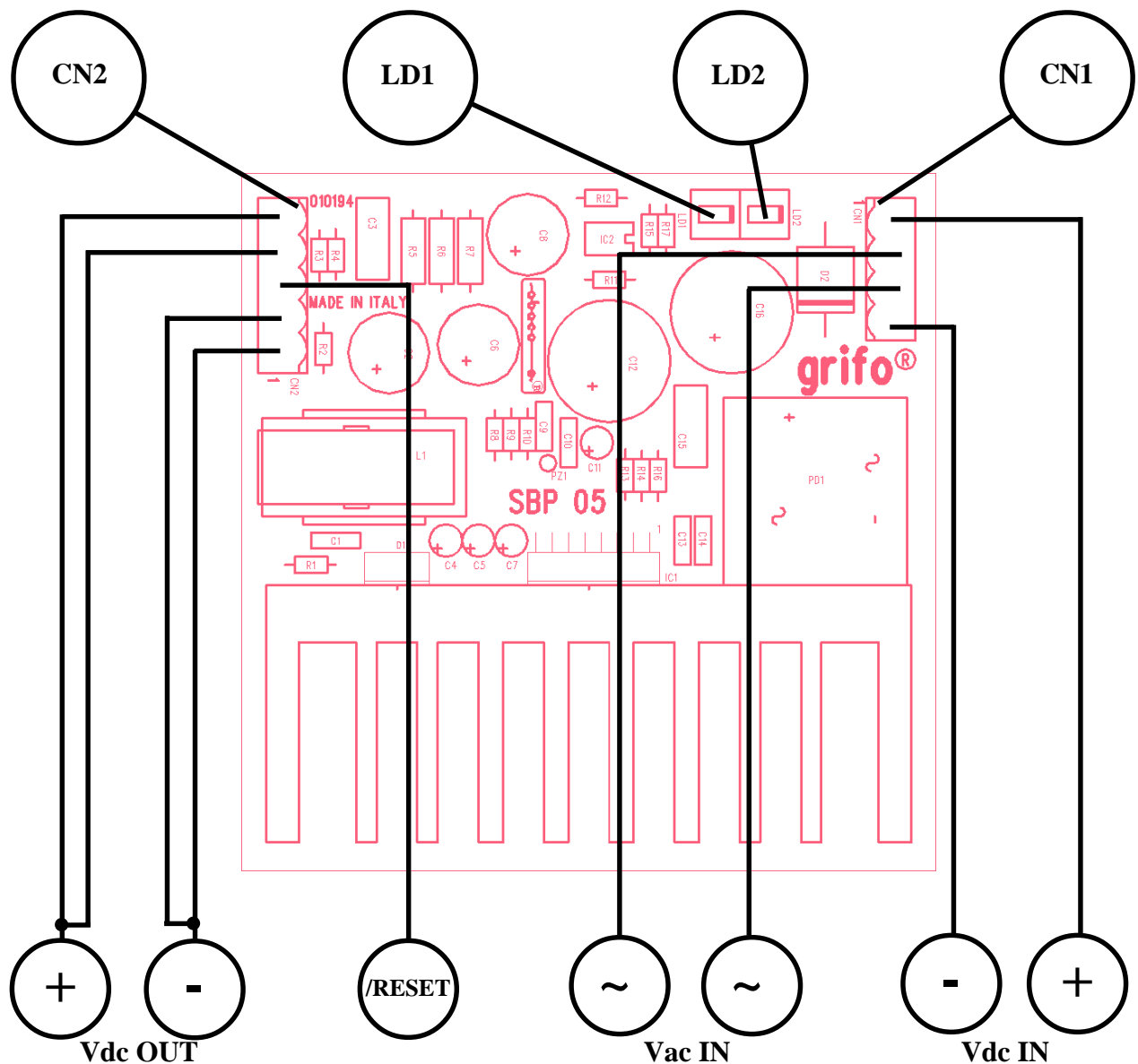

FIGURE 8: LEDs, CONNECTORS, VOLTAGES, ETC. LOCATION

/RESET AND POWER FAILURE

Switching section of models **SBP 05/10** generate a /RESET signal that informs eventual users of regulated output voltage validity. In detail /RESET is an open collector signal that, when closed, connects to negative terminal of output voltage (-) GND. Its status has the following meaning:

- Contact open -> /RESET = (+) Vdc OUT -> Regulated output voltage is valid
- Contact closed -> /RESET = (-) GND -> Regulated output voltage not valid because input voltage is too low or output voltage is out of range

The sections warrants at least 10 msec of duration for the signal (contact closed) to provide enough intervent time to the external circuitry.

Previous description shows that /RESET signal acts also as power failure and can be matched to microprocessor-based boards with the same signal with no problem.

INPUT VOLTAGES AND UPS

Connector CN1 features two pins for AC input voltage and two separated pins for DC input voltage; these should be used only in the possible combinations described here:

- 1) unique AC voltage on pins 2 and 3 of CN1;
- 2) AC voltage on pins 2 and 3 of CN1 and back up DC voltage on pins 1 and 4 of CN1;
- 3) DC voltage on pins 2 and 3 of CN1 and back up DC voltage on pins 1 and 4 of CN1;

Please remark that (-) GND signal of CN2 is physically connected to -Vdc IN signal of CN1 to warrant the same ground potential between output voltage and DC input voltage; differently, in case 3 ground of DC input voltage is not physically connected to ground of regulated output voltage. In fact the two grounds differ of about 1.5 V, typical difference of potential due to the bridge rectifier. In cases 2 and 3 **SBP 05/10** acts as an UPS, that is should the voltage on pins 2 and 3 black out the regulated output voltage is still present through back up input voltage, which is usually provided by an opportune battery.

POWER PROVIDED

Power supply **SBP 05/10** can provide a maximum power that changes according to the model, in fact the module can always provide the maximum output current 5 or 10 A regardless the output voltage selected, as described in the following table:

MODEL	Vac Vdc IN	Power IN	Vdc OUT	Power OUT
SBP 05	10÷33 Vac or 13÷46 Vdc	34.4 W	5 Vdc	25 W
SBP 05.12	12÷33 Vac or 17÷46 Vdc	82.5 W	12 Vdc	60 W
SBP 05.15	14÷33 Vac or 20÷46 Vdc	103.1 W	15 Vdc	75 W
SBP 05.24	22÷33 Vac or 31÷46 Vdc	165.0 W	24 Vdc	120 W
SBP 10	10÷33 Vac or 13÷46 Vdc	68.8 W	5 Vdc	50 W
SBP 10.12	12÷33 Vac or 17÷46 Vdc	165.0 W	12 Vdc	120 W
SBP 10.15	14÷33 Vac or 20÷46 Vdc	206.3 W	15 Vdc	150 W
SBP 10.24	22÷33 Vac or 31÷46 Vdc	330.0 W	24 Vdc	240 W

FIGURE 9: POWER FOR EACH MODEL TABLE

Values of input power reported are referred to average efficiency of power supply (80%) and increased of 10%. For safety it is always opportune to choose a greater power and an input voltage close to the maximum value reported. To obtain maximum output power it is essential to provide an input voltage with the features specified in figure 9 considering that such values are referred to an environmental temperature of 20 °C. Changes of this temperature may influence remarkably both maximum output power and output voltage: the user must employ all techniques to keep temperature in admitted range.

SBP 05/10 features components and circuits designed to reduce noise sensibility and increase efficiency; also, the layout has been carefully tracked to carry the generated power in the best way possible, avoiding mass rings, instability, emissions, etc.

EXTERNAL DEVICES FOR SBP 05 AND SBP 10

The seven models of **SBP 05/10** can supply most of **grifo®** cards, or many systems of other companies. Most common applications are to provide power supply to mother boards, galvanically isolated input and output sections, or to many **GPC® xxx** control cards. As an example here is reported a list with a short description of overall performances; for further information please consult specific documentation.

MB3 01 , MB4 01 , MB8 01 , WMB 12 , WMB 16 , MMB 21

Mother Board 3, 4, 8, 12, 16, 21 slots

Motherboard with 3, 4, 8, 12, 16, or 21 slots of **ABACO®** industrial BUS industriale; slot pitch 4 or 5 TE; standardized power supply connectors; LEDs for supply visual feed back; local reset key; termination resistors on signals; holes for docking to rack 3 HE.

ABB 03

ABACO® Block BUS 3 slots

3 slots **ABACO®** mother board; 4 TE pitch connectors; **ABACO®** I/O BUS connector; screw terminal for power supply; connection for DIN C type and Ω rails.

OBI 01 - OBI 02

Opto BLOCK Input NPN-PNP

Interface between 16 NPN, PNP optocoupled and displayed input lines, with screw terminal and **ABACO®** standard I/O 20 pins connector; power supply section; connection for DIN Ω rails.

OBI N8 - OBI P8

Opto BLOCK Input NPN-PNP

Interface between 8 NPN, PNP optocoupled and displayed input lines, with screw terminal and **ABACO®** standard I/O 20 pins connector; power supply section; connection for DIN Ω rails.

TBO 01 - TBO 08

Transistor BLOCK Output

Interface for **ABACO®** standard I/O 20 pins connector; 16 or 8 transistor output lines 45 Vdc 3 A open collector; screw terminal; optocoupled and displayed lines; connection for DIN 247277-1 and 3 rails.

RBO 08 - RBO 16

Relé BLOCK Output

Interface for **ABACO®** standard I/O 20 pins connector; 8 or 16 displayed Relays 3A with MOV; screw terminal; connection for DIN Ctype and Ω rails.

XBI 01

miXed BLOCK Input Output

Interface for **ABACO®** standard I/O 20 pins connector; 8 transistor output lines 45 Vdc 3A; 8 input lines; screw terminal; optocoupled and displayed I/O lines; connection for DIN 247277-1 and 3 rails.

XBI R4 - XBI T4

miXed BLOCK Input-Output

Interface for **ABACO®** standard I/O 20 pins connector; 4 Relays 3A with MOV or 4 optocoupled Transistors 3A open collectors; 4 input lines optocoupled; screw terminal; connection for DIN Ctype and Ω rails.

FBC xxx

Flat Block Contactxxx pins

This interconnection system "wire to board" allows the connection to many type of flat cable connectors to terminal for external connections. Connection for DIN Ω rails.
for DIN 247277-1 and 3 rails; 4 type dimension.

CI/O R16

16 Coupled Input Output Relé

16 optocoupled input with π -filter; input voltage 24 Vdc. 16 micro-relays 1 A with disturb suppression by MOV 24 Vac. I/O visualized through LEDs; 8 bit BUS; standard addressing.

PCI 01

32 Peripheral Coupled Input

16 optocoupled input with π -filter; input voltage 24 Vdc; I/O visualized through LEDs; 8 or 16 bit BUS; standard addressing.

JMS 34

Jumbo Multifunction Support for axis control

Smart peripheral for axis control; 3 optocoupled inputs for acquisition of incremental bidirectional encoders; zero sign; 4 D/A converter channels 12 bits; output range ± 10 V; 8 NPN optocoupled inputs; 8 Open Collector transistor outputs 45 Vdc, 500 mA; all I/O visualized through LEDs; 8 bit BUS; extended addressing.

GPC® 188F

General Purpose Controller 80C188

80C188 μ P 20MHz; 1 RS 232 line; 1 RS 232, RS 422-485 or Current Loop line; 24 TTL I/O lines; 1M EPROM or 512K FLASH; 1M RAM Lithium battery backed; 8K serial EEPROM; RTC; Watch Dog; 8 Dip switch; 3 Timer Counter; 8 13 bit A/D lines; Power failure; activity LEDs; single power supply +5Vdc.

GPC® 554

General Purpose Controller 80C552

Microprocessor 80C552 at 22 MHz; implementation completely CMOS; 32K EPROM; 32 K SRAM; 32 K EEPROM or SRAM; EEPROM; 2 RS 232 serial lines; 16 I/O TTL; 2 PWM lines; 16 bits Timer/Counter; Watch Dog; 6 signals A/D converter with resolution 10 bit; interface for **ABACO®** I/O BUS.

GPC® 154

"4" Type General Purpose Controller Z80

84C15 μ P, 10÷16 MHz; Full CMOS; 1 RS 232 line; 1 RS 232 or RS 422-485 line; 16 TTL I/O lines; 2÷4 Timers Counters; 512K EPROM or FLASH; 512K RAM and RTC backed; 8K serial EEPROM; Watch dog; 2 readable DIPs; LCD Interface; Abaco® I/O BUS; 5Vdc Power supply; Size: 100x50 mm.

IPC 52

Intelligent Peripheral Controller, 24 analogic input

This intelligent peripheral card acquires 24 independent analogic input lines: 8 PT 100 or PT 1000 sensors, 8 J,K,S,T termocouples, 8 analog input ± 2 Vdc or 4÷20mA; 16 bits + sign A/D section; 0.1 °C resolution; 32K RAM for local data logging; buzzer; 16 TTL I/O lines; 5 or 8 conversion per second; facility of networking up to 127 IPC 52 cards using serial line. BUS interfacing or through RS 232, RS 422, RS 485 or current loop line. Only 5Vdc power supply.

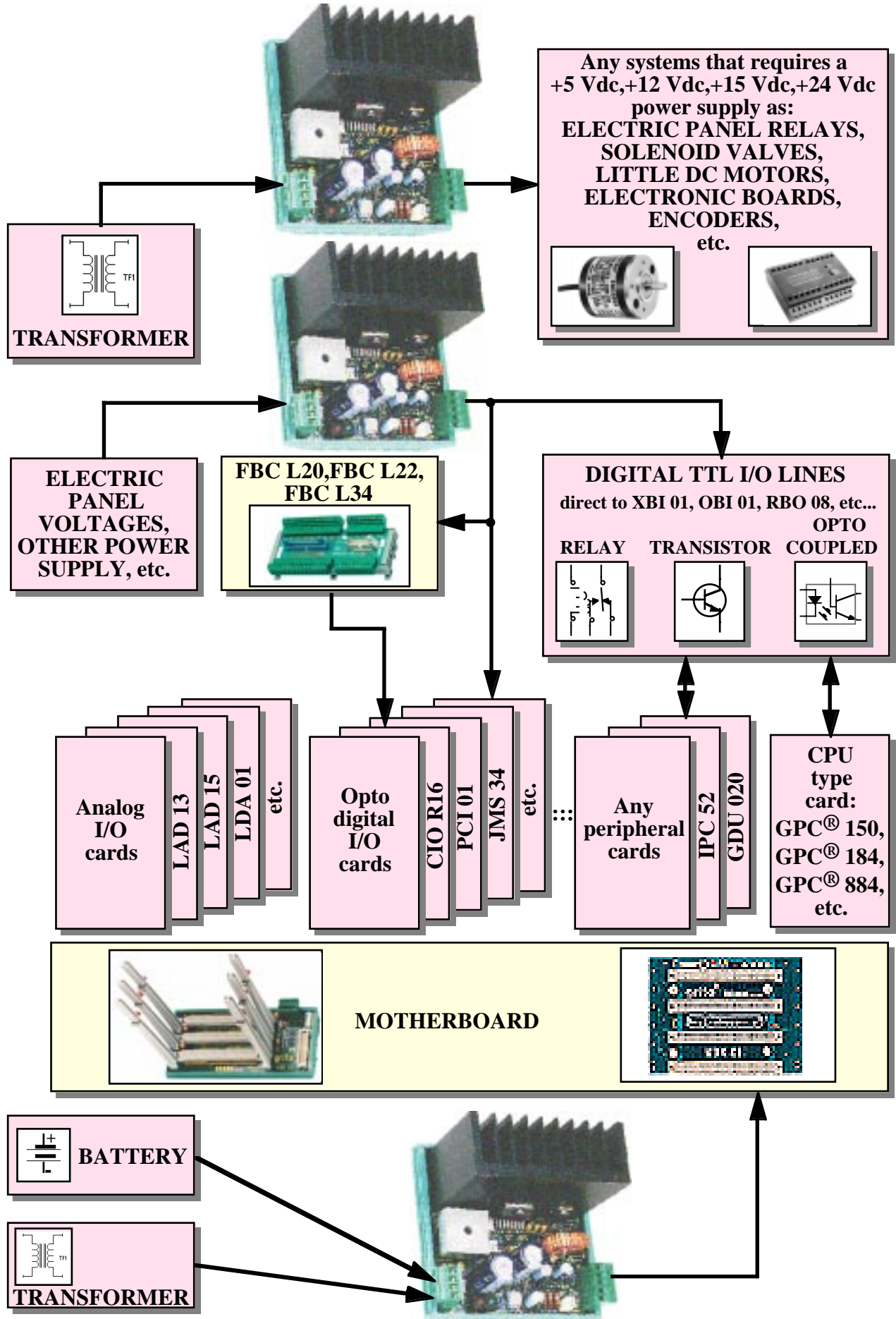

FIGURE 10: POSSIBLE CONNECTIONS DIAGRAM

BIBLIOGRAPHY

In this chapter there is a complete list of technical books, where the user can find all the necessary documentations on the components mounted on **SBP 05** and **SBP 10**.

Manuals SGS: *Power supply application manual*
GS-R modules application manual

Manual Motorola semiconductor: *Rectifiers and zener diodes data book*

Manual Harris: *Passive components data book*

For further information and upgrades please refer to specific internet web pages of the manufacturing companies.

APPENDIX A: ALPHABETICAL INDEX

AAVERAGE EFFICENCY **8****B**BATTERY **10, 14**BIBLIOGRAPHY **18**BLOCK DIAGRAM **5****C**CARD VERSION **1**COMPONENTS MAP **6**CONNECTORS **8, 13** CN1 **10** CN2 **11****D**DUTY CYCLE **4****E**EXTERNAL DEVICES **15****F**FILTERS **6**FUSE **12****I**INPUT VOLTAGE FREQUENCY **8**INPUT VOLTAGES **8, 9**INPUT VOLTAGES **10, 12****L**L4970 **4**LEDS **12****M**MODELS **8, 9, 14**MOUNTING **8**

O

OUTPUT CURRENT 9

P

POWER 14

POWER FAILURE 13

PROTECTIONS 4, 8

OVERHEAT 12

OVERLOAD 12

SHORT CIRCUIT 12

UNDER VOLTAGE IN INPUT 12

R

RELATIVE HUMIDITY 8

RESET 4, 8, 13

S

SBP 05 3

SBP 10 7

SCREW TERMINAL 10, 11

SENSING 4, 11

SIZE 8

SOFT START 4, 12

SWITCHING FREQUENCY 8

T

TEMPERATURE 14

TEMPERATURE RANGE 8

TRANSFORMER 10

U

UPS 14

V

VISUAL FEEDBACK 12

W

WEIGHT 8