

# ZBT N88 ZBT P88

Zipped BLOCK Transistors  
8 Input/Output NPN o PNP

## TECHNICAL MANUAL



**grifo**<sup>®</sup>

ITALIAN TECHNOLOGY

Via dell' Artigiano, 8/6  
40016 San Giorgio di Piano  
(Bologna) ITALY

E-mail: [grifo@grifo.it](mailto:grifo@grifo.it)

<http://www.grifo.it>

<http://www.grifo.com>

Tel. +39 051 892.052 (a.r.) FAX: +39 051 893.661



ZBT x88

Edition 5.00 Rel. 25 November 1999

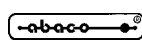
 , GPC<sup>®</sup>, grifo<sup>®</sup>, are trade marks of grifo<sup>®</sup>



# ZBT N88 ZBT P88

**Zipped BLOCK Transistors  
8 Input/Output NPN o PNP**

## TECHNICAL MANUAL

### **ZBT N88**

#### **Zipped BLOCK Transistors NPN, 8 Input, 8 Output**

Peripheral featuring 8 optocoupled and displayed NPN Inputs; Eight 4A NPN Darlington transistor with back EMF protection diode; Screw terminal connectors for optocoupled inputs and outputs; Standard 26 pins **ABACO® I/O BUS** connector; Visualization LEDs; On board power supply section to generate +5 Vdc and +Vopto; Galvanically isolated supply sections; Optional quick connection to DIN 46277-1 and 3 rails.

### **ZBT P88**

#### **Zipped BLOCK Transistors PNP, 8 Input, 8 Output**

Peripheral featuring 8 optocoupled and displayed PNP Inputs; Eight 4A PNP Darlington transistor with back EMF protection diode; Screw terminal connectors for optocoupled inputs and outputs; Standard 26 pins **ABACO® I/O BUS** connector; Visualization LEDs; On board power supply section to generate +5 Vdc and +Vopto; Galvanically isolated supply sections; Optional quick connection to DIN 46277-1 and 3 rails.

**grifo®**

ITALIAN TECHNOLOGY

Via dell' Artigiano, 8/6  
40016 San Giorgio di Piano  
(Bologna) ITALY

E-mail: [grifo@grifo.it](mailto:grifo@grifo.it)

<http://www.grifo.it>

<http://www.grifo.com>

Tel. +39 051 892.052 (a.r.) FAX: +39 051 893.661



**ZBT x88**

Edition 5.00 Rel. 25 November 1999

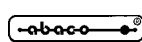
, **GPC®**, **grifo®**, are trade marks of **grifo®**

## DOCUMENTATION COPYRIGHT BY grifo<sup>®</sup>, ALL RIGHTS RESERVED.

No part of this document may be reproduced, transmitted, transcribed, stored in a retrieval system, or translated into any language or computer language, in any form or by any means, either electronic, mechanical, magnetic, optical, chemical, manual, or otherwise, without the prior written consent of **grifo<sup>®</sup>**.

### IMPORTANT

Although all the information contained herein have been carefully verified, **grifo<sup>®</sup>** assumes no responsibility for errors that might appear in this document, or for damage to things or persons resulting from technical errors, omission and improper use of this manual and of the related software and hardware.

**grifo<sup>®</sup>** reserves the right to change the contents and form of this document, as well as the features and specification of its products at any time, without prior notice, to obtain always the best product.

For specific informations on the components mounted on the card, please refer to the Data Book of the builder or second sources.

### SYMBOLS DESCRIPTION

In the manual could appear the following symbols:



Attention: Generic danger



Attention: High voltage

### Trade marks

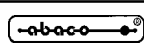
 <sup>®</sup>, GPC<sup>®</sup>, **grifo<sup>®</sup>** : are trade marks of **grifo<sup>®</sup>**.

Other Product and Company names listed, are trade marks of their respective companies.

# GENERAL INDEX

INTRODUCTION .....	1
CARDS VERSIONS .....	2
GENERAL FEATURES .....	2
OUTPUT SECTION .....	4
INPUT SECTION .....	4
CONTROL LOGIC .....	6
INTERFACING AND ADDRESSING SECTION .....	6
INTERFACING TO /INT AND /NMI SECTION .....	6
POWER SUPPLY SECTION .....	6
TECHNICAL FEATURES OF ZBT N88 .....	8
GENERAL FEATURES OF ZBT N88 .....	8
PHYSICAL FEATURES OF ZBT N88 .....	8
ELECTRIC FEATURES OF ZBT N88 .....	8
TECHNICAL FEATURES OF ZBT P88 .....	10
GENERAL FEATURES OF ZBT P88 .....	10
PHYSICAL FEATURES OF ZBT P88 .....	10
ELECTRIC FEATURES OF ZBT P88 .....	10
INSTALLATION .....	12
CONNECTIONS .....	12
CN3 - AUXILIARY POWER SUPPLY CONNECTOR .....	12
CN1 - ABACO® I/O BUS CONNECTOR .....	13
CN2 - LOW VOLTAGE POWER SUPPLY CONNECTOR .....	14
CN4 - ZBT N88 /NMI AND /INT NPN OPTOCOUPLED INPUT CONNECTOR ...	16
CN4 - ZBT P88 /NMI AND /INT PNP OPTOCOUPLED INPUT CONNECTOR ...	18
CN5 - ZBT N88 OPTOCOUPLED INPUTS CONNECTOR .....	20
CN5 - ZBT P88 OPTOCOUPLED INPUTS CONNECTOR .....	22
CN6 - ZBT N88 NPN TRANSISTOR OUTPUT CONNECTOR .....	24
CN6 - ZBT P88 PNP TRANSISTOR OUTPUT CONNECTOR .....	26
VISUAL SIGNALATIONS .....	28
JUMPERS .....	30
2 PINS JUMPERS .....	30
14 PINS ADDRESSING JUMPER .....	32
I/O CONNECTIONS .....	33
SUPPLY VOLTAGES SELECTION .....	33
HARDWARE DESCRIPTION .....	35
INTRODUCTION .....	35
BOARD MAPPING .....	35
INTERNAL REGISTERS ADDRESSING .....	36

<b>PERIPHERAL DEVICES SOFTWARE DESCRIPTION .....</b>	<b>37</b>
<b>TRANSISTOR OUTPUTS .....</b>	<b>37</b>
<b>OPTOCOUPLED INPUTS.....</b>	<b>38</b>
<b>EXTERNAL CARDS .....</b>	<b>39</b>
<b>BIBLIOGRAPHY .....</b>	<b>44</b>
<b>APPENDIX A: CARD MECHANICAL MOUNTING .....</b>	<b>A-1</b>
<b>APPENDIX B: ALPHABETICAL INDEX .....</b>	<b>B-1</b>



# FIGURES INDEX

<b>FIGURE 1: ZBT N88 CARD PHOTO</b> .....	<b>3</b>
<b>FIGURE 2: BLOCK DIAGRAM</b> .....	<b>5</b>
<b>FIGURE 3: ZBT P88 CARD PHOTO</b> .....	<b>7</b>
<b>FIGURE 4: ZBT N88 COMPONENTS MAP</b> .....	<b>9</b>
<b>FIGURE 5: ZBT P88 COMPONENTS MAP</b> .....	<b>11</b>
<b>FIGURE 6: CN3 - AUXILIARY POWER SUPPLY CONNECTOR</b> .....	<b>12</b>
<b>FIGURE 7: CN1 - ABACO® I/O BUS CONNECTOR</b> .....	<b>13</b>
<b>FIGURE 8: CN2 - MAINS POWER SUPPLY CONNECTOR</b> .....	<b>14</b>
<b>FIGURE 9: ZBT N88 CONNECTORS LOCATION</b> .....	<b>15</b>
<b>FIGURE 10: ZBT P88 CONNECTORS LOCATION</b> .....	<b>15</b>
<b>FIGURE 11: CN4 - /NMI AND /INT NPN SIGNALS OPTOCOUPLED INPUT ON ZBT N88</b> .....	<b>16</b>
<b>FIGURE 12: ZBT N88 /INT AND /NMI NPN OPTOCOUPLED INPUTS BLOCK DIAGRAM</b> .....	<b>17</b>
<b>FIGURE 13: CN4 - /NMI AND /INT PNP SIGNALS OPTOCOUPLED INPUT ON ZBT P88</b> .....	<b>18</b>
<b>FIGURE 14: ZBT P88 /INT AND /NMI PNP OPTOCOUPLED INPUTS BLOCK DIAGRAM</b> .....	<b>19</b>
<b>FIGURE 15: CN5 - ZBT N88 OPTOCOUPLED NPN INPUTS CONNECTOR</b> .....	<b>20</b>
<b>FIGURE 16: ZBT N88 OPTOCOUPLED NPN INPUT SECTION BLOCK DIAGRAM</b> .....	<b>21</b>
<b>FIGURE 17: CN5 - ZBT P88 OPTOCOUPLED PNP INPUTS CONNECTOR</b> .....	<b>22</b>
<b>FIGURE 18: ZBT P88 OPTOCOUPLED PNP INPUT SECTION BLOCK DIAGRAM</b> .....	<b>23</b>
<b>FIGURE 19: CN6 - ZBT N88 NPN TRANSISTOR OUTPUT CONNECTOR</b> .....	<b>24</b>
<b>FIGURE 20: ZBT N88 NPN TRANSISTOR OUTPUT BLOCK DIAGRAM</b> .....	<b>25</b>
<b>FIGURE 21: CN6 - ZBT P88 PNP TRANSISTOR OUTPUT CONNECTOR</b> .....	<b>26</b>
<b>FIGURE 22: ZBT P88 PNP TRANSISTOR OUTPUT BLOCK DIAGRAM</b> .....	<b>27</b>
<b>FIGURE 23: VISUAL SIGNALATIONS TABLE</b> .....	<b>28</b>
<b>FIGURE 24: ZBT N88 LEDs, JUMPERS AND FUSES LOCATION</b> .....	<b>29</b>
<b>FIGURE 25: JUMPERS SUMMARIZING TABLE</b> .....	<b>30</b>
<b>FIGURE 26: 2 PINS JUMPERS SUMMARIZING TABLE</b> .....	<b>30</b>
<b>FIGURE 27: ZBT P88 LEDs, JUMPERS AND FUSES LOCATION</b> .....	<b>31</b>
<b>FIGURE 28: ADDRESSING JUMPERS TABLE</b> .....	<b>32</b>
<b>FIGURE 29: ZBT N88 AND ZBT P88 INTERNAL REGISTERS ADDRESSING TABLE</b> .....	<b>36</b>
<b>FIGURE 30: EXTERNAL CONNECTIONS DIAGRAM</b> .....	<b>41</b>
<b>FIGURE A1: ZBT x88 AND A CPU SERIE 4 CARDS IN WEIDMULLER RAIL MOUNTING</b> .....	<b>A-1</b>



## INTRODUCTION

The use of these devices has turned - IN EXCLUSIVE WAY - to specialized personnel.

The purpose of this handbook is to give the necessary information to the cognizant and sure use of the products. They are the result of a continual and systematic elaboration of data and technical tests saved and validated from the manufacturer, related to the inside modes of certainty and quality of the information.

The reported data are destined- IN EXCLUSIVE WAY- to specialized users, that can interact with the devices in safety conditions for the persons, for the machine and for the enviroment, impersonating an elementary diagnostic of breakdowns and of malfunction conditions by performing simple functional verify operations , in the height respect of the actual safety and health norms.

The informations for the installation, the assemblage, the dismantlement, the handling, the adjustment, the reparation and the contingent accessories, devices etc. installation are destined - and then executable - always and in exclusive way from specialized warned and educated personnel, or directly from the TECHNICAL AUTHORIZED ASSISTANCE, in the height respect of the manufacturer recommendations and the actual safety and health norms.

The devices can't be used outside a box. The user must always insert the cards in a container that respect the actual safety normative. The protection of this container is not threshold to the only atmospheric agents, but specially to mechanic, electric, magnetic, etc. ones.

To be on good terms with the products, is necessary guarantee legibility and conservation of the manual, also for future references. In case of deterioration or more easily for technical updates, consult the AUTHORIZED TECHNICAL ASSISTANCE directly.

To prevent problems during card utilization, it is a good practice to read carefully all the informations of this manual. After this reading, the user can use the general index and the alphabetical index, respectly at the begining and at the end of the manual, to find information in a faster and more easy way.

## CARDS VERSIONS

The present manual is reported to the versions of **ZBT N88** or **ZBT P88** below reported:

- **ZBT N88:** version **120799** and later.
- **ZBT P88:** version **120799** and later.

The validity of the bring informations is subordinate to the number of the card release. The user must always verify the correct correspondence among the two denotations. Version number is printed on the boards in several positions both in serigraph and in printed circuit.

## GENERAL FEATURES

**ZBT x88** (**Z**ipped **B**LOCK **T**ransistors **8** Input **8** Output) serie boards are Input - Output peripheral modules in **BLOCK** format featuring **ABACO® I/O BUS** interface and  $\Omega$  rail mounting capabilities. The amount of input and output signals available depends on the model, in particular:

- **ZBT N88:** 8 optocoupled NPN Input signals, 8 NPN Darlington Transistor Output signals.
- **ZBT P88:** 8 optocoupled PNP Input signals, 8 PNP Darlington Transistor Output signals.

**ZBT N** or **P 88** I/O modules take an extremely small room, nevertheless they feature a middle number of Input - Output signals provided with two separate power supply sections. The first supply section outputs 5 Vdc, it can supply on board logic, output Darlington transistors and also an eventual external logic, such as other peripherals or a CPU section. The second supply section, galvanically isolated, can supply the optocouplers section lade by Inputs and also other eventual external peripherals.

Typical applications for **ZBT N** or **P 88** serie boards are the ones that require a small number of logic I/O signals. These signals are available on the modules that can be mounted on an  $\Omega$  rail in any electromechanical control panel; the wires can be directly connected to quick release screw terminal connectors and the powers can be supplied directly by secondary transformer. All I/O lines are always equipped with **LEDs** that show the line status; these LEDs are in grid with their correspondent connector terminals, just to simplify the installation and for solving problems during hardware test and software debug phases. Also power supply sections have diagnostic LEDs to inform user about possible malfunctions.

In addition to I/O logical lines, two optocoupled and displayed lines directly connected to the **/INT** and **/NMI BUS** interrupt signals. There is also the possibility to read the set 8 logical outputs status, on a dedicated register.

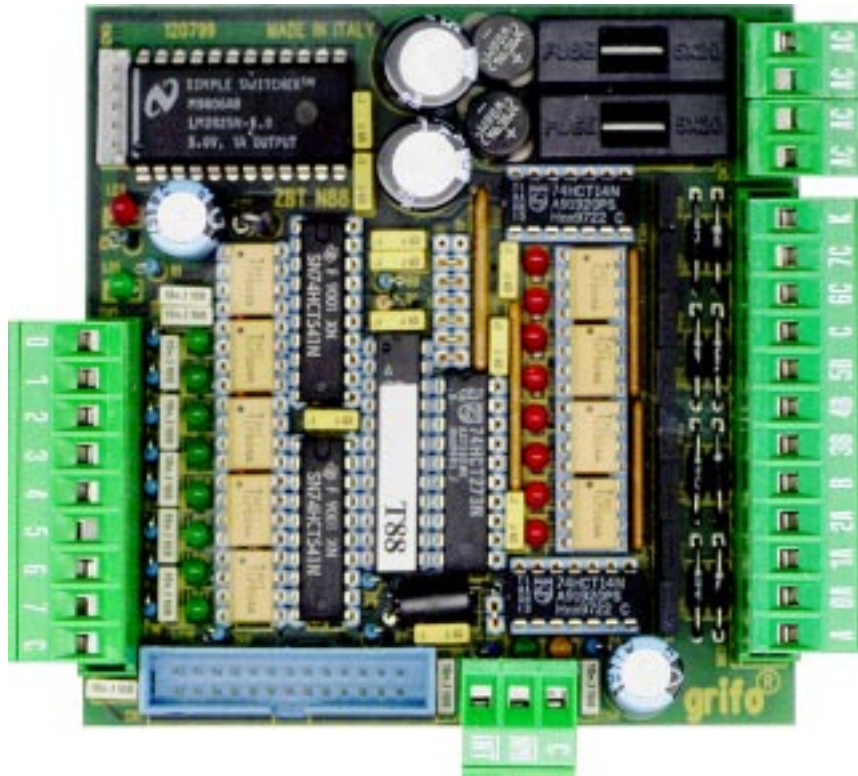

FIGURE 1: ZBT N88 CARD PHOTO

The **ZBT N88** and **ZBT P88** are the simplest I/O expansion for BLOCK CPU cards connected through the **ABACO® I/O BUS** expansion connector, such as **GPC® 15R**, **GPC® 153**, **GPC® 183**, **GPC® 323**, **GPC® 553**, **GPC® 324**, **GPC® 114**, **GPC® 554**, **GPC® 184**, **GPC® 154**, **GPC® 884**, **GPC® AM4** and so on. The card can be combined event to single Euro size cards with **ABACO® BUS** interface through the proper mother boards **ABB 03** or **ABB 05** and a simple 26 wires flat cable.

- **BLOCK** card, 100x95 mm size, planed for plastic container provided of Omega rails holder (**BLOCK.x88** option).
- **ABACO® I/O BUS** interface with standard 26 pins connector.
- **8 NPN** or **PNP** input lines optocoupled, displayed by LEDs and provided with RC filters.
- Optocoupled and displayed NPN or PNP input lines for generating **/INT** and **/NMI** signals.
- **8 NPN** or **PNP** digital outputs lines buffered with **4 A**, 45Vdc, Darlington transistors displayed by LEDs.
- All the 8 output lines are optocoupled, readable by software and without radiator.
- Standard **quick release screw terminal** connectors, for all I/O lines.
- Only **2 Bytes** used for card I/O addressing.
- Standard connector for powering external devices.
- Built in stabilized power supply for on board Darlington and electronics.
- Power supply, galvanically coupled from the other one, for Optocoupled input section.
- Protection **fuses** against power supply short circuit.
- Duoble external low voltage power supply: **15÷18 Vac** or **+5** and **+24 Vdc** (other configurations available).

Here follows a description of **ZBT N88** and **ZBT P88** boards' functional blocks, with an indication of the operations performed by each one. To easily locate these blocks and verify their connections please refer to figures 1 and 2.

## OUTPUT SECTION

This section features 8 Output signals driven by one or more latches. These components are managed through specific read/write registers, according to the informations contained in the chapters dedicated to board's hardware and software description. Any Output signal, galvanically isolated and visualized through its own LED, controls a 45 Vdc, 4A (not continuous) NPN or PNP Darlington transistor, connecte in Open Collector, provided with a back EMF protection diode.

## INPUT SECTION

This section features 8 NPN or PNP Input signals, acquired through input buffers. These components are managed by specific read/write registers, according to the informations contained in the chapters dedicated to board's hardware and software description. Any Input signal is galvanivally isolated and visualized through its own LED, green on **ZBT N88** and yellow on **ZBT P88**. Optocouplers of this section are supplied through +Vopto voltage generated by the specific power supply section.

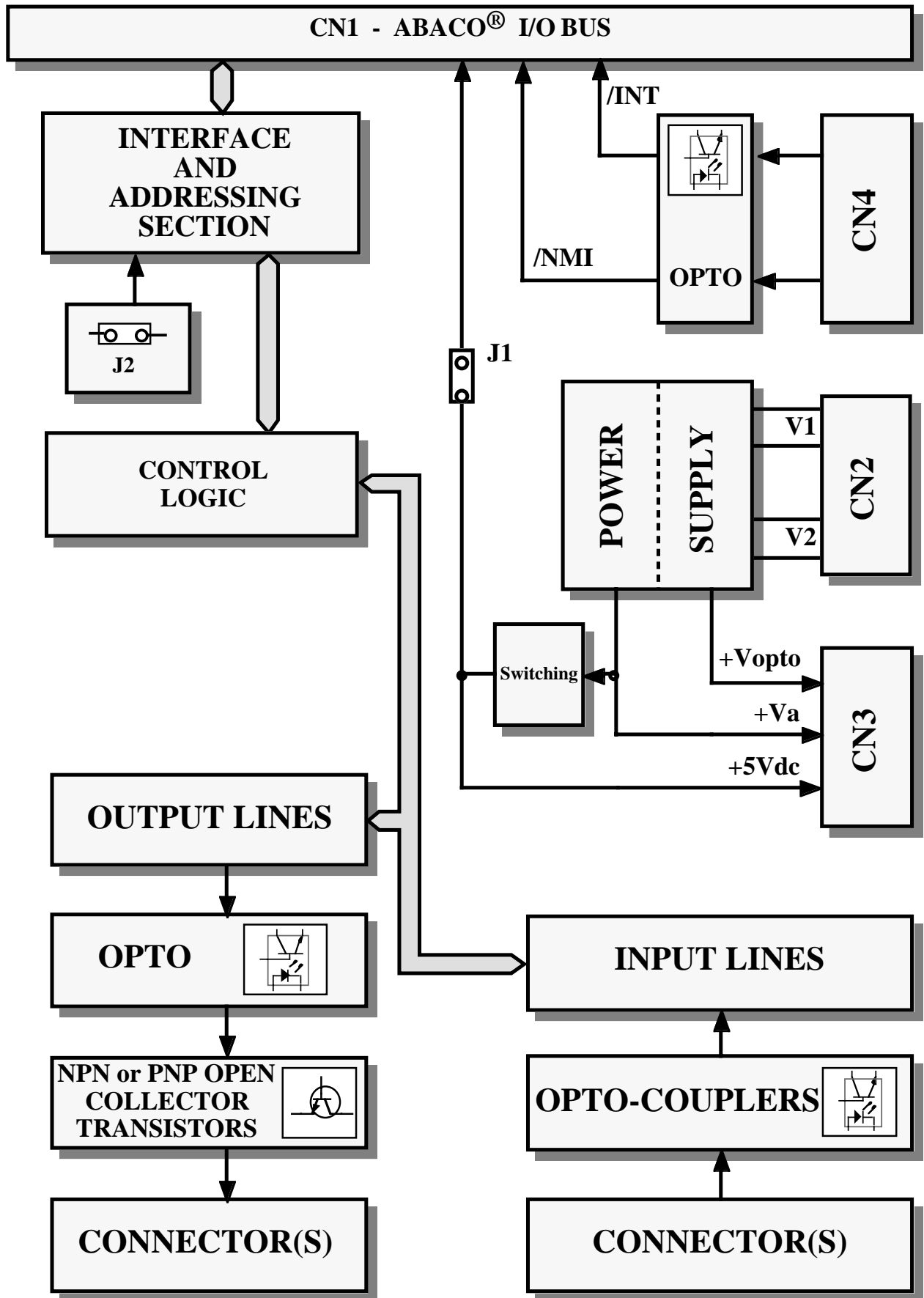

FIGURE 2: BLOCK DIAGRAM

## CONTROL LOGIC

This section generates all the chip-select signals needed to access the several peripherals on **ZBT N88** and **ZBT P88** boards. Using this section the programmer can interact to the board's several sections, verifying their status, reading digital input configurations, setting output signals, etc.

All this can be done through a simple software management based on **ABACO® I/O BUS**, to which the control logic connects through the interfacing and addressing section. For further information please refer to the chapter dedicated to board's software description.

## INTERFACING AND ADDRESSING SECTION

This section manages the data exchange between control logic and command board through **ABACO® I/O BUS**. In particular, all written or read data transit across this section that, in addition, provides the board I/O management, by setting a specific jumper called **J2**.

For further information please refer to the chapter dedicated to board's software description.

## INTERFACING TO /INT AND /NMI SECTION

This section, which is based on two optocoupled NPN or PNP inputs and two visualization LEDs, allows to interface two signals to **/INT** and **/NMI ABACO® I/O BUS** signals.

Using this feature the User can always promptly and efficiently react to particular external events.

## POWER SUPPLY SECTION

**ZBT N88** and **ZBT P88** boards feature an efficient supply circuitry including: a switching power supply providing +5 Vdc supply voltage needed to Output and logic section, under several conditions of load and input voltage; a simple rectifying group generates +Vopto voltage needed to supply Input signals optocouplers.

These voltages are also available on CN3 connector contacts; this way it is also possible to supply eventual external modules, such as a control card.

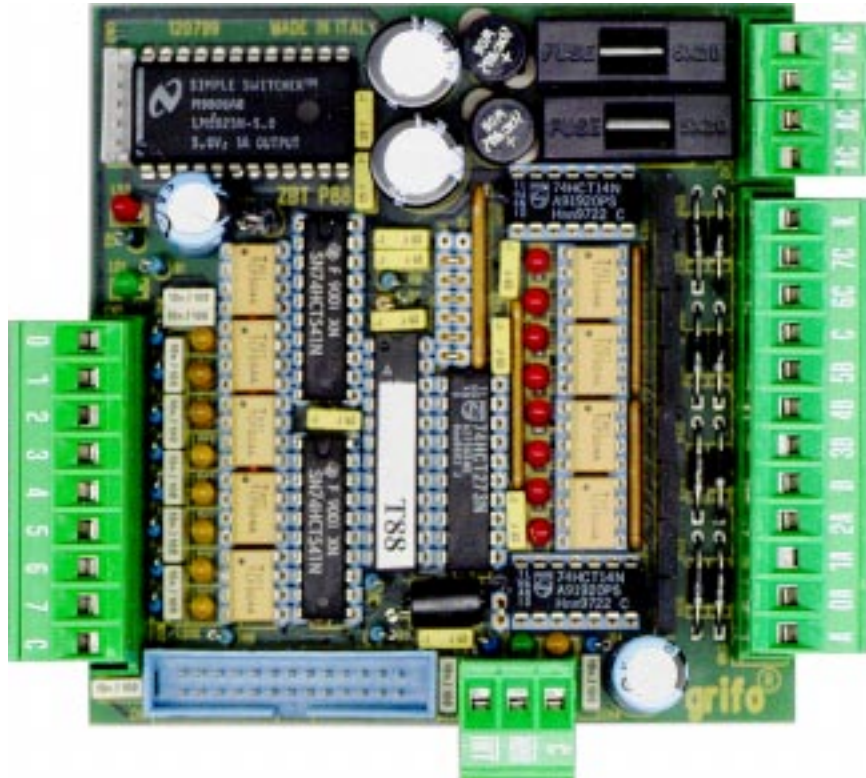

FIGURE 3: ZBT P88 CARD PHOTO

## TECHNICAL FEATURES OF ZBT N88

### GENERAL FEATURES OF ZBT N88

BUS Type:	<b>ABACO® I/O</b>
On board resources:	8 NPN Optocoupled Inputs 8 NPN Open Collector 4 A Darlington transistor Outputs 2 NPN Optocoupled Inputs for /NMI and /INT BUS signals
Power supplies:	Provided with disturb and noise suppressor filter

### PHYSICAL FEATURES OF ZBT N88

Connectors:	CN1: 26 pins low profile vertical M ( <b>ABACO® I/O BUS</b> ) CN2: 4 quick release screw terminal (Power supply) CN3: 5 pins low profile vertical M (Supply external loads) CN4: 3 pins quick release (/NMI and /INT Inputs) CN5: 9 pins quick release ( <b>IN1</b> Optocoupled Inputs) CN6: 12 pins quick release ( <b>OUT1</b> NPN Outputs)
Size:	100 x 95 mm
Weight:	169 g 256 g with $\Omega$ rail plastic container ( <b>optional</b> )
Temperature range:	from 0 to 50 Centigrad degreeses
Relative Humidity:	20% up to 90% (without condense)

### ELECTRIC FEATURES OF ZBT N88

F1 fuse:	1 A; 250 V delayed
F2 fuse:	1 A; 250 V delayed

To easily locate the fuses please refer to figure 24.

Consumption:	104 mA max (+5 Vdc) 50 mA max (+Vopto = 18 Vac)
--------------	--

Maximum current for transistor:	4 A <b>not continuous</b>	*
Maximum tension for transistor:	45 Vdc	*
Maximum power for transistor:	1.25 W <b>without heat sink</b>	*

*Low voltage power supply version*

Required tensions: V2 (+5 Vdc) 15÷18 Vac or 18÷24 Vdc  
 V1 (+Vopto) 15÷18 Vac or 18÷24 Vdc

Provided tensions: +5 Vdc 4 W (800 mA) \*  
 +Vopto 12.5 W \*

*Stabilized power supply version*

Required and provided tension: +5 Vdc  
 +18÷24 Vdc (+Vopto)

\* Data here reported are referred to 20 Centigrad degrees of environmental temperature

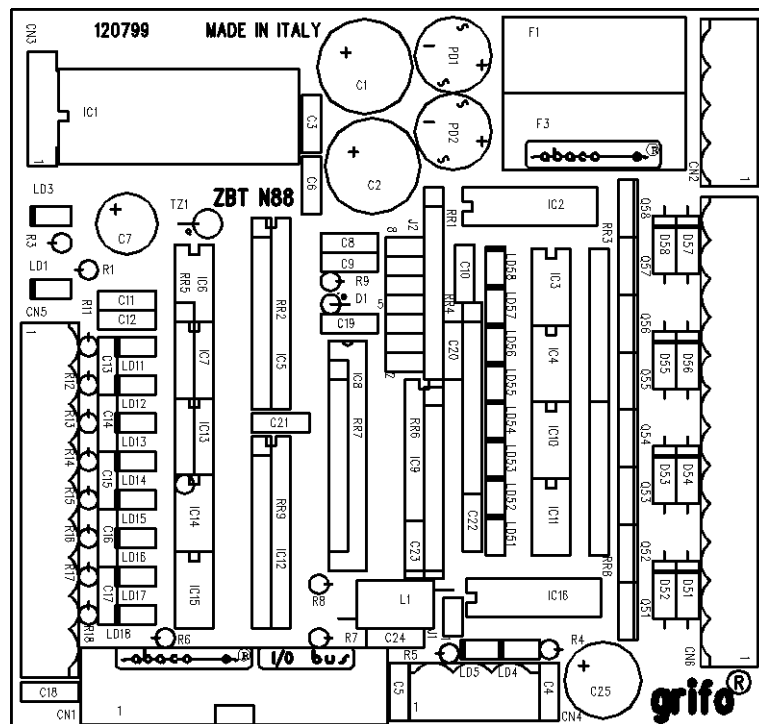

**FIGURE 4: ZBT N88 COMPONENTS MAP**

## TECHNICAL FEATURES OF ZBT P88

### GENERAL FEATURES OF ZBT P88

BUS Type:	<b>ABACO® I/O</b>
On board resources:	8 PNP Optocoupled Inputs 8 PNP Open Collector 4 A Darlington transistor Outputs 2 PNP Optocoupled Inputs for /NMI and /INT BUS signals
Power supplies:	Provided with disturb and noise suppressor filter

### PHYSICAL FEATURES OF ZBT P88

Connectors:	CN1: 26 pins low profile vertical M ( <b>ABACO® I/O BUS</b> ) CN2: 4 quick release screw terminal (Power supply) CN3: 5 pins low profile vertical M (Supply external loads) CN4: 3 pins quick release (/NMI and /INT Inputs) CN5: 9 pins quick release ( <b>IN1</b> Optocoupled Inputs) CN6: 12 pins quick release ( <b>OUT1</b> PNP Outputs)
Size:	100 x 95 mm
Weight:	169 g 256 g with $\Omega$ rail plastic container ( <b>optional</b> )
Temperature range:	from 0 to 50 Centigrad degrees
Relative Humidity:	20% up to 90% (without condense)

### ELECTRIC FEATURES OF ZBT P88

F1 fuse:	1 A; 250 V delayed
F2 fuse:	1 A; 250 V delayed

To easily locate the fuses please refer to figure 27.

Consumption:	104 mA max (+5 Vdc) 50 mA max (+Vopto = 18 Vac)
--------------	--

Maximum current for transistor:	4 A <b>not continuous</b>	*
Maximum tension for transistor:	45 Vdc	*
Maximum power for transistor:	1.25 W <b>without heat sink</b>	*

*Low voltage power supply version*

Required tensions: V2 (+5 Vdc) 15÷18 Vac or 18÷24 Vdc  
 V1 (+Vopto) 15÷18 Vac or 18÷24 Vdc

Provided tensions: +5 Vdc 4 W (800 mA) \*  
 +Vopto 12.5 W \*

*Stabilized power supply version*

Required and provided tension: +5 Vdc  
 +18÷24 Vdc (+Vopto)

\* Data here reported are referred to 20 Centigrad degrees of environmental temperature

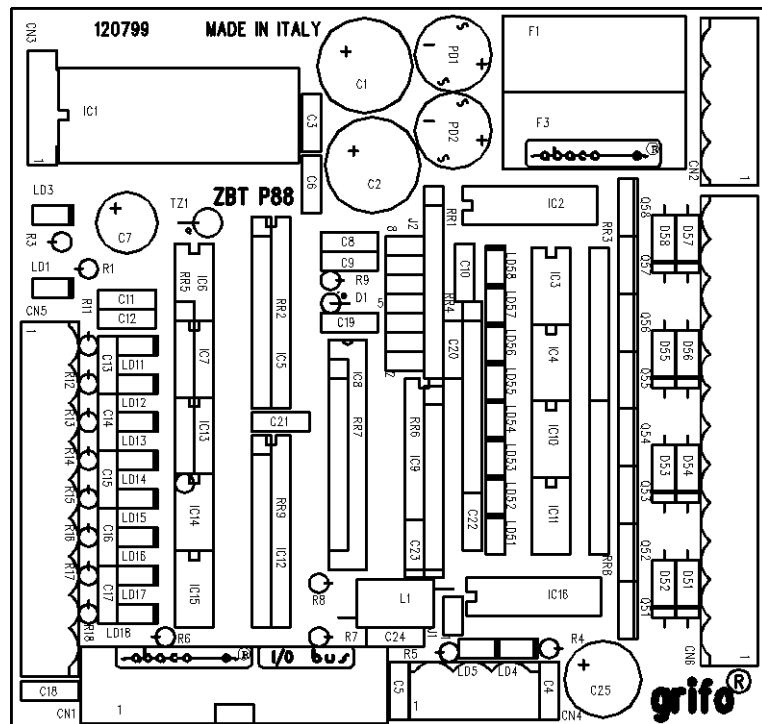

FIGURE 5: ZBT P88 COMPONENTS MAP

## INSTALLATION

In this chapter there are the information for a right installation and correct use of **ZBT N88** and **ZBT P88** cards. The user can find the location and functions of each connectors, trimmers, jumpers and some explanatory diagrams.

### CONNECTIONS

The **ZBT N88** and **ZBT P88** cards have several connectors that can be linked to other devices or directly to the field, according to system requirements. In this paragraph there are connectors pin outs, a short signals description (including the signals direction) and connectors location (see figure referring to the **ZBT N88** and **ZBT P88** in use), plus some figures that describe how the interface signals are connected on the card.

#### **CN3 - AUXILIARY POWER SUPPLY CONNECTOR**

CN3 is a 5 pins low profile vertical male 2.54 mm pitch connector.

If the **ZBT N88** or **ZBT P88** card is provided with on board power supply, the two galvanically isolated voltages generated by this section can be accessed through CN3, to supply external loads. Otherwise, if the **ZBT N88** or **ZBT P88** card is provided with on board power supply, through CN3 it is possible to provide the card +5 Vdc and +Vopto voltages, essential to supply correctly the card itself (for further informations please see the paragraph “ SUPPLY VOLTAGES SELECTION”).

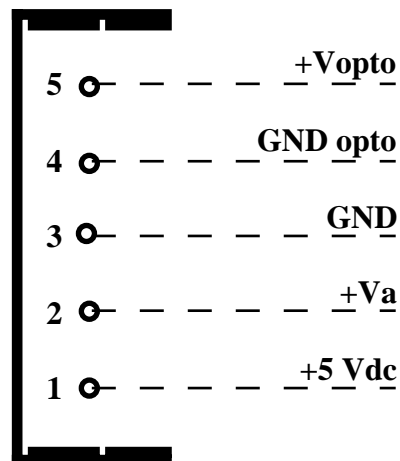

**FIGURE 6: CN3 - AUXILIARY POWER SUPPLY CONNECTOR**

Signals description:

<b>+Vopto</b>	= I/O - Positive terminal of external optocoupled I/O supply
<b>GND opto</b>	= - Common terminal of external optocoupled I/O supply
<b>GND</b>	= O - Ground signal
<b>+Va</b>	= O - Positive terminal of board switching supply input voltage
<b>+5 Vdc</b>	= I/O - +5 Vdc supply signal

**CN1 - ABACO® I/O BUS CONNECTOR**

CN1 is a 26 pins, male, vertical, low profile connector with 2,54 mm pitch.

Through CN1 the **ZBT N88** or **ZBT P88** card can be connected to external expansion modules developed by the user or to the numerous **grifo®** boards, both intelligent and not. All this connector signals are at TTL level and follows the **ABACO®** I/O BUS standard.

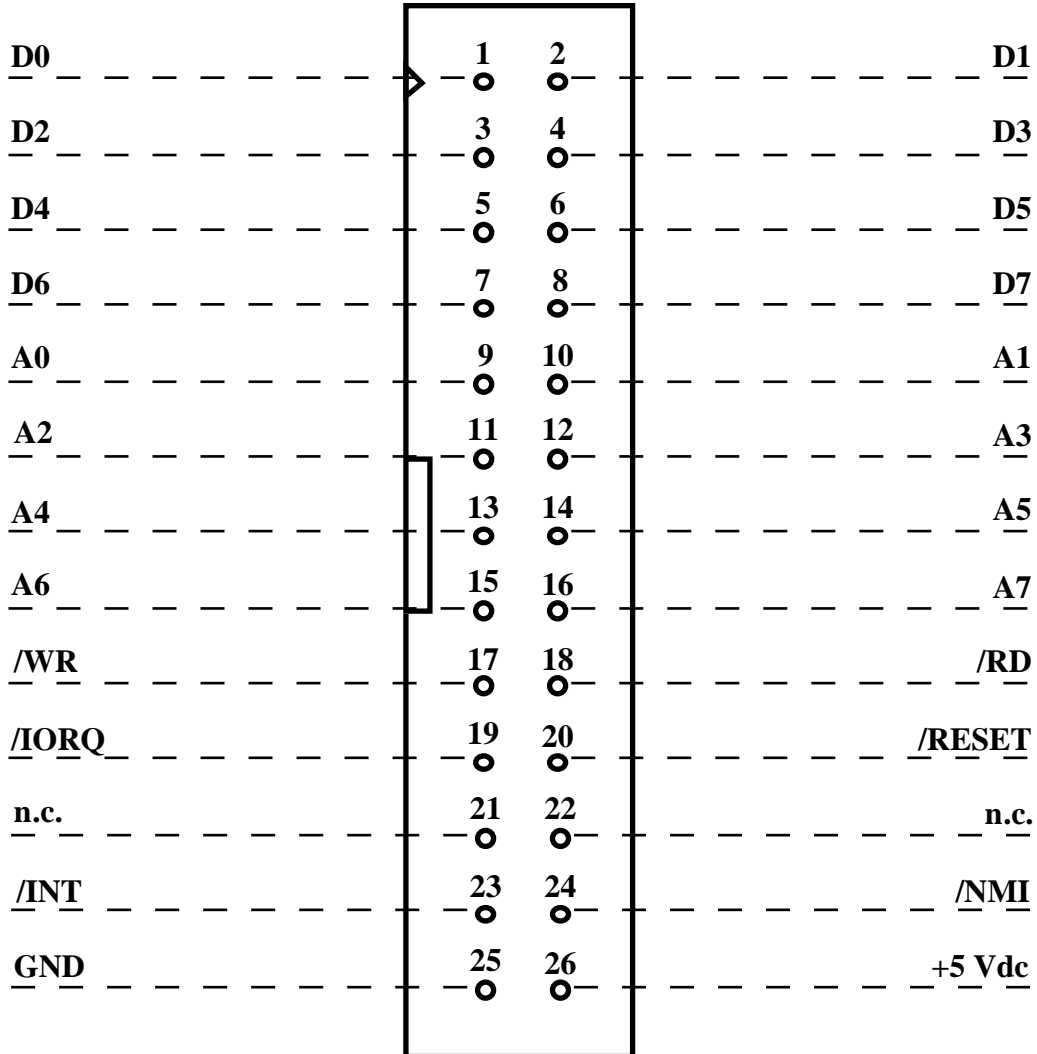

**FIGURE 7: CN1 - ABACO® I/O BUS CONNECTOR**

Signals description:

- A0-A7** = O - Address BUS.
- D0-D7** = I/O - Data BUS.
- /INT BUS** = I - Interrupt request (open collector type).
- /NMI BUS** = I - Non maskable interrupt (open collector type).
- /IORQ** = O - Input output request.
- /RD** = O - Read cycle status.
- /WR** = O - Write cycle status.
- /RESET** = O - Reset.
- +5 Vdc** = I/O - +5 Vdc power supply.
- GND** = - Ground signal.
- N.C.** = - Not connected

**CN2 - LOW VOLTAGE POWER SUPPLY CONNECTOR**

CN2 is a 4 pins quick release screw terminal connector. Through CN2 low voltage is provided to on board power supply section, properly configured (for further informations please see the paragraph “ SUPPLY VOLTAGES SELECTION”).

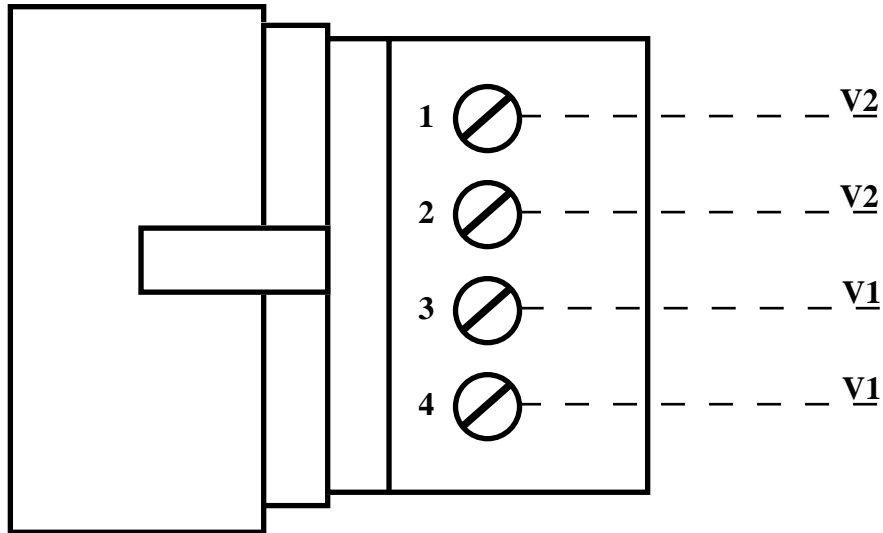

**FIGURE 8: CN2 - MAINS POWER SUPPLY CONNECTOR**

Signals description:

- V1** = I - Vopto power supply signals
- V2** = I - +5 Vdc power supply signals

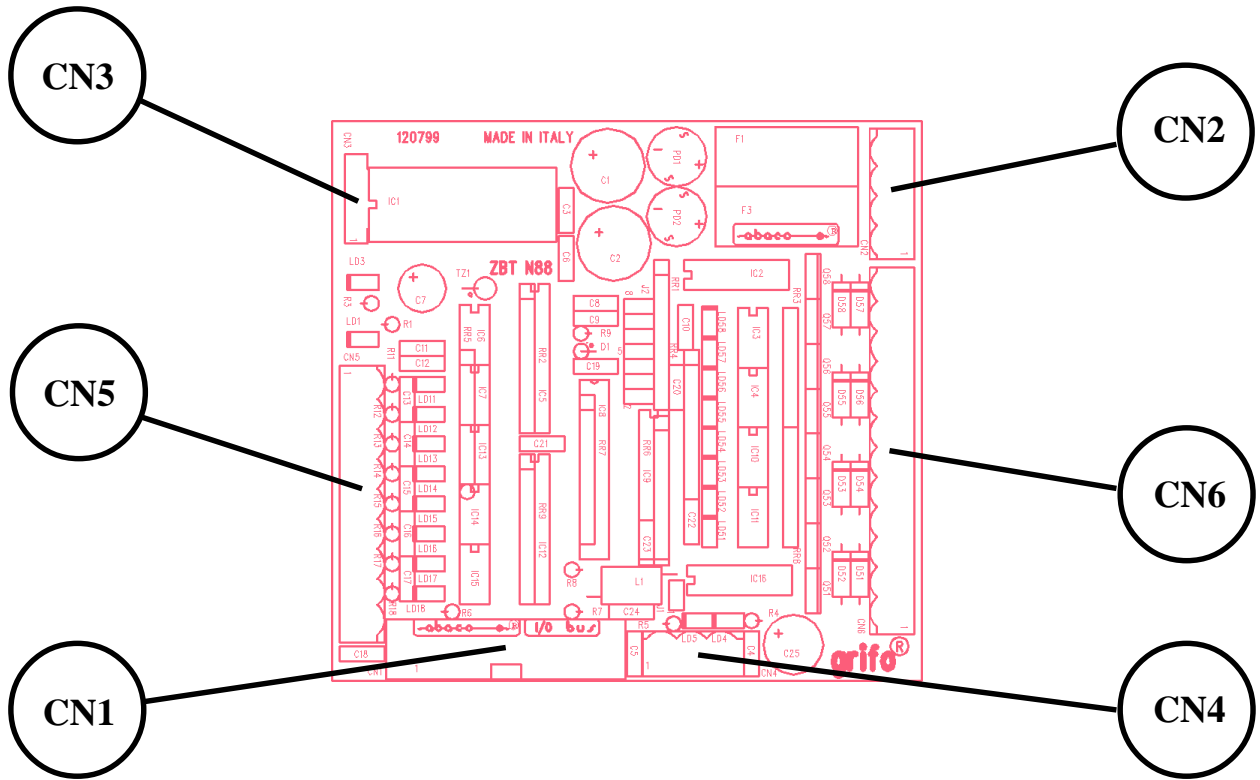

FIGURE 9: ZBT N88 CONNECTORS LOCATION

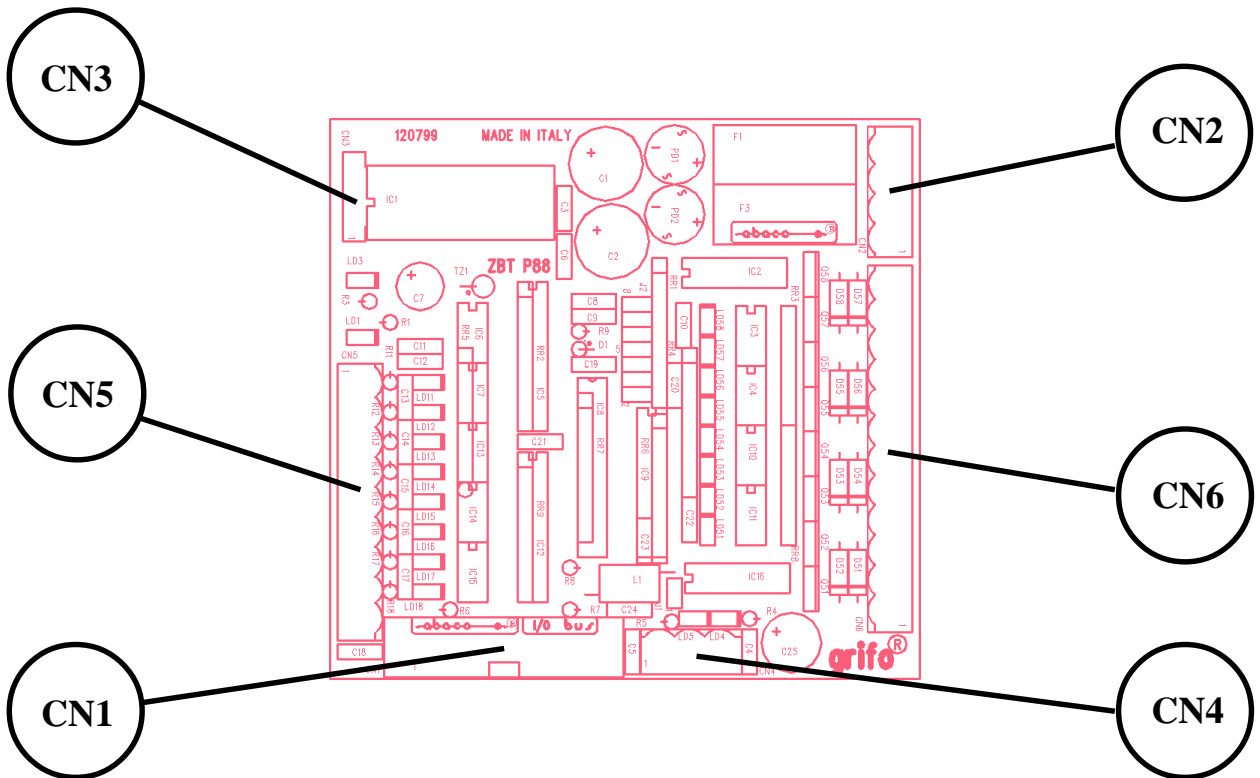
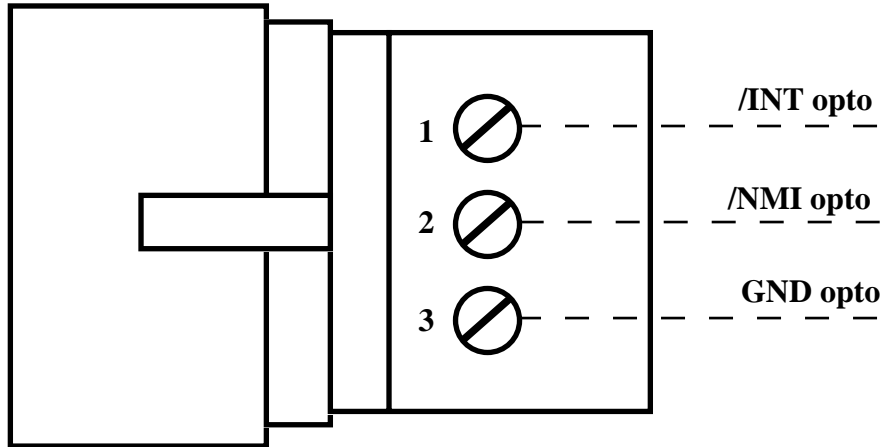

FIGURE 10: ZBT P88 CONNECTORS LOCATION

**CN4 - ZBT N88 /NMI AND /INT NPN OPTOCOUPLED INPUT CONNECTOR**

CN4 is a 3 pins quick release screw terminal connector. By CN4 two signals coming from external world can be connected to /NMI and /INT signals of **ABACO® I/O BUS**, through specific **NPN** Optocoupled inputs.



**FIGURE 11: CN4 - /NMI AND /INT NPN SIGNALS OPTOCOUPLED INPUT ON ZBT N88**

Signals description:

- /NMI opto** = I - Open collector NPN input interfaced to /NMI signal
- /INT opto** = I - Open collector NPN input interfaced to /INT signal
- GND opto** = - Common terminal of Optocoupled inputs

The two NPN input lines for /NMI and /INT signals are Optocoupled to warrant a high degree of protection for on board electronics against noise and disturbs from the external world.

Both signals are provided with a LED for visual feed back (the LED will light whenever the input will have the potential of GND opto signal); this means that the inputs are going to support normally open contacts.

The interface circuitry for /NMI and /INT signals is shown in the following diagram.

The Optocouplers power supply is generated by on board power supply or, if the **ZBT N88** board is not provided with power supply circuitry, must be provided through the specific connector CN3.

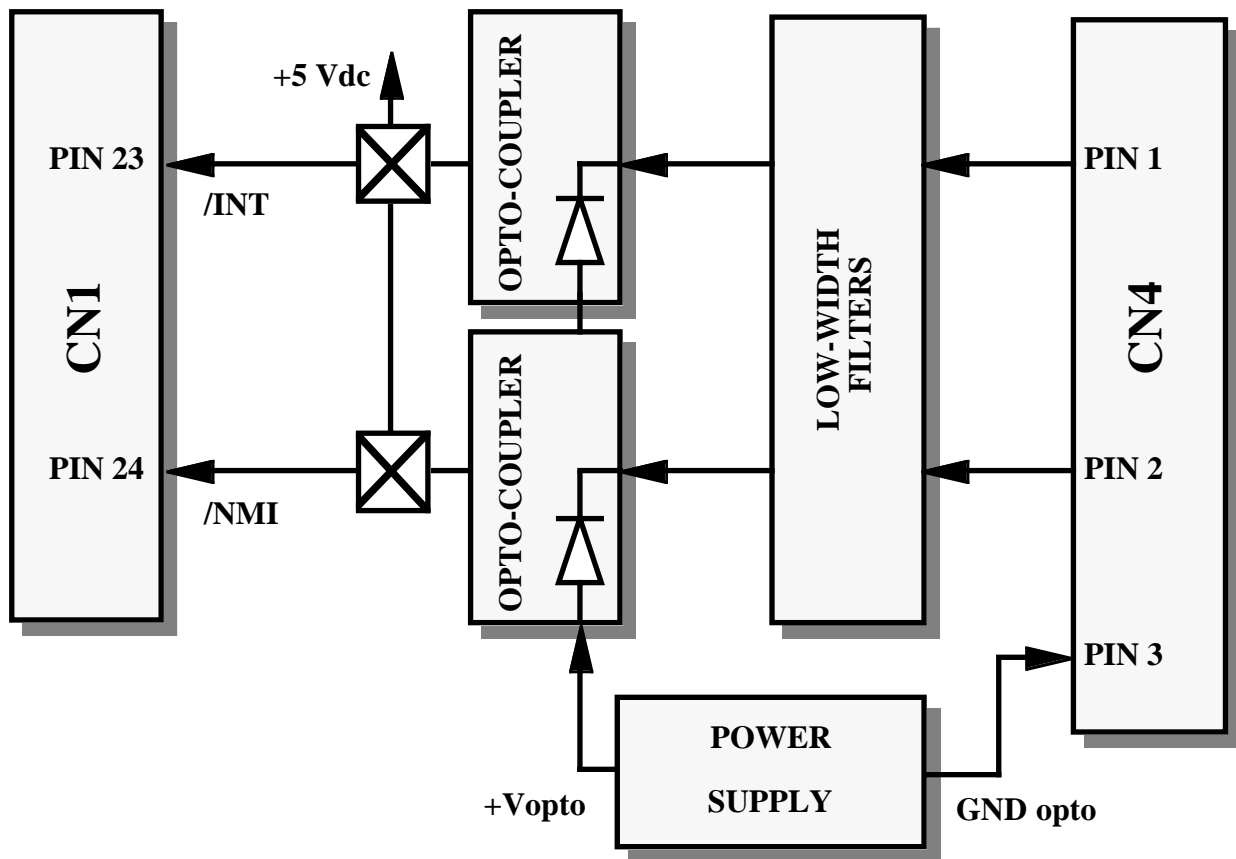
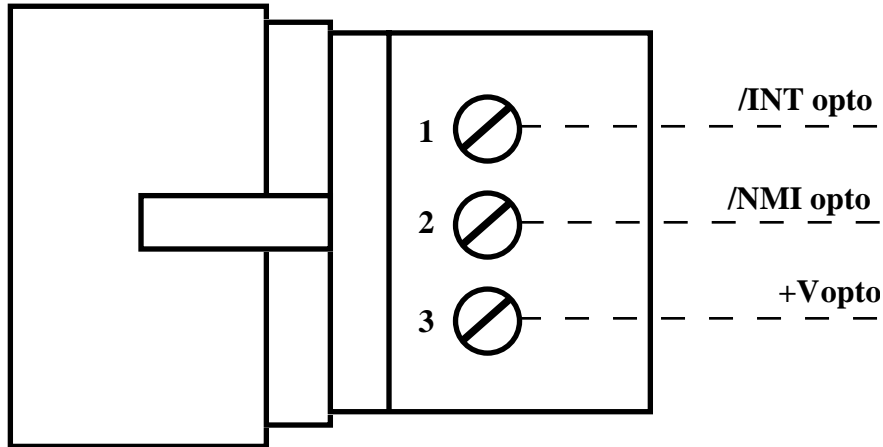

FIGURE 12: ZBT N88 /INT AND /NMI NPN OPTOCOUPLED INPUTS BLOCK DIAGRAM

**CN4 - ZBT P88 /NMI AND /INT PNP OPTOCOUPLED INPUT CONNECTOR**

CN4 is a 3 pins quick release screw terminal connector. By CN4 two signals coming from external world can be connected to /NMI and /INT signals of ABACO® I/O BUS, through specific PNP Optocoupled inputs.



**FIGURE 13: CN4 - /NMI AND /INT PNP SIGNALS OPTOCOUPLED INPUT ON ZBT P88**

Signals description:

- /NMI opto** = I - Open collector PNP input interfaced to /NMI signal
- /INT opto** = I - Open collector PNP input interfaced to /INT signal
- +Vopto** = - Supply terminal of Optocoupled inputs

The two PNP input lines for /NMI and /INT signals are Optocoupled to warrant a high degree of protection for on board electronics against noise and disturbs from the external world.

Both signals are provided with a LED for visual feed back (the LED will light whenever the input will have the potential of +Vopto signal); this means that the inputs are going to support normally open contacts.

The interface circuitry for /NMI and /INT signals is shown in the following diagram.

The Optocouplers power supply is generated by on board power supply or, if the **ZBT P88** board is not provided with power supply circuitry, must be provided through the specific connector CN3.

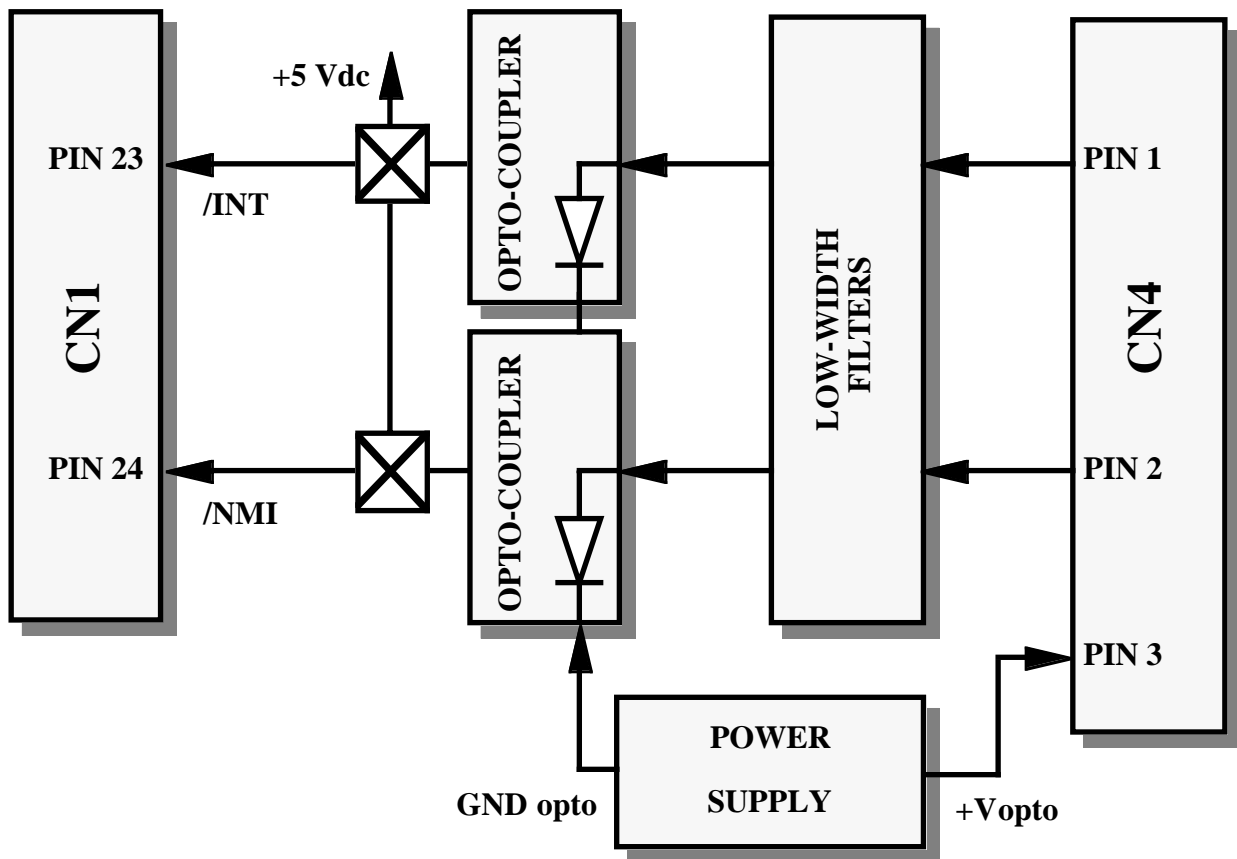

FIGURE 14: ZBT P88 /INT AND /NMI PNP OPTOCOUPLED INPUTS BLOCK DIAGRAM

## CN5 - ZBT N88 OPTOCOUPLED INPUTS CONNECTOR

CN5 is a 9 pins quick release screw terminal connector. By CN5 eight optocoupled **NPN** inputs of **ZBT N88** card can be connected to the external world, in particular the **IN1** inputs section. Open Collector NPN inputs and optocoupled section supply common terminal are present.

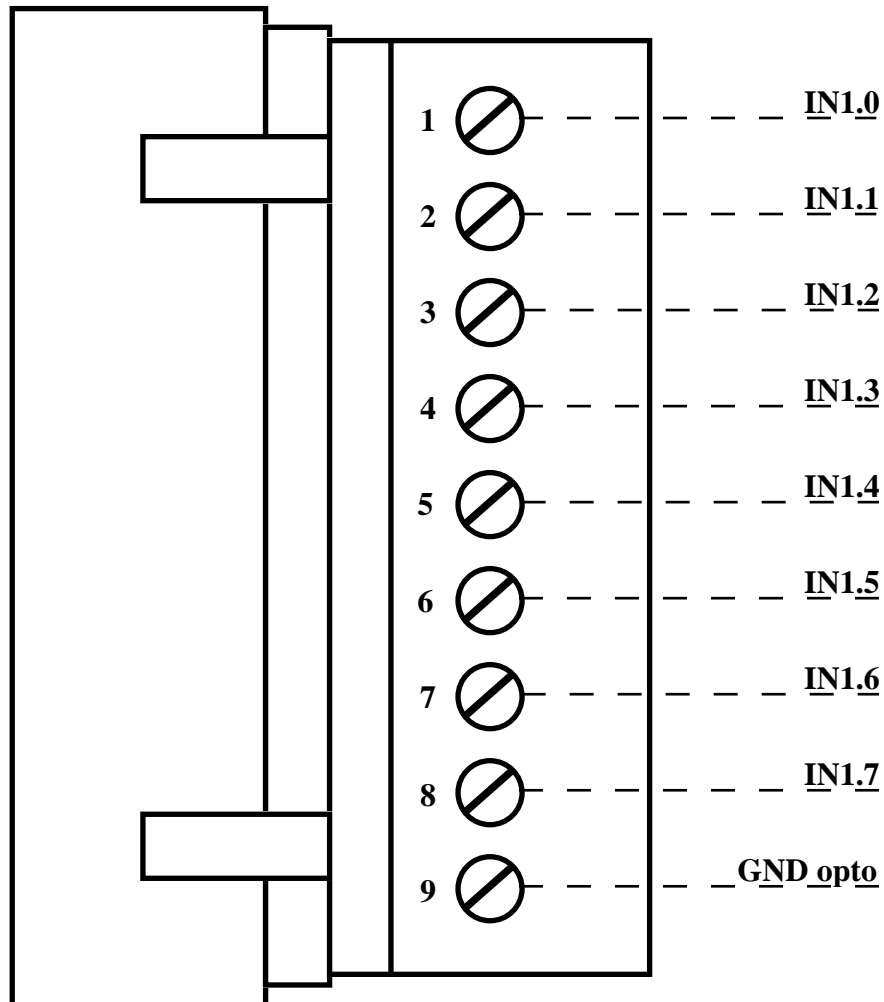

FIGURE 15: CN5 - ZBT N88 OPTOCOUPLED NPN INPUTS CONNECTOR

Signals description:

**IN1.n** = I - NPN Open Collector input connected to IN1 section  
**GND\_opto** = - Common terminal of Optocoupled inputs

The NPN input signals available on **ZBT N88** are Optocoupled to warrant a high degree of protection for on board electronics against noise and disturbs from the external world.

Each signal is provided with a LED for visual feed back (the LED will light whenever the input will have the potential of GND opto signal); this means that the inputs are going to support normally open contacts

The interface circuitry for this input section is shown in the following diagram.

The Optocouplers power supply is generated by on board power supply or, if the **ZBT N88** board is not provided with power supply circuitry, must be provided through the specific connector CN3.

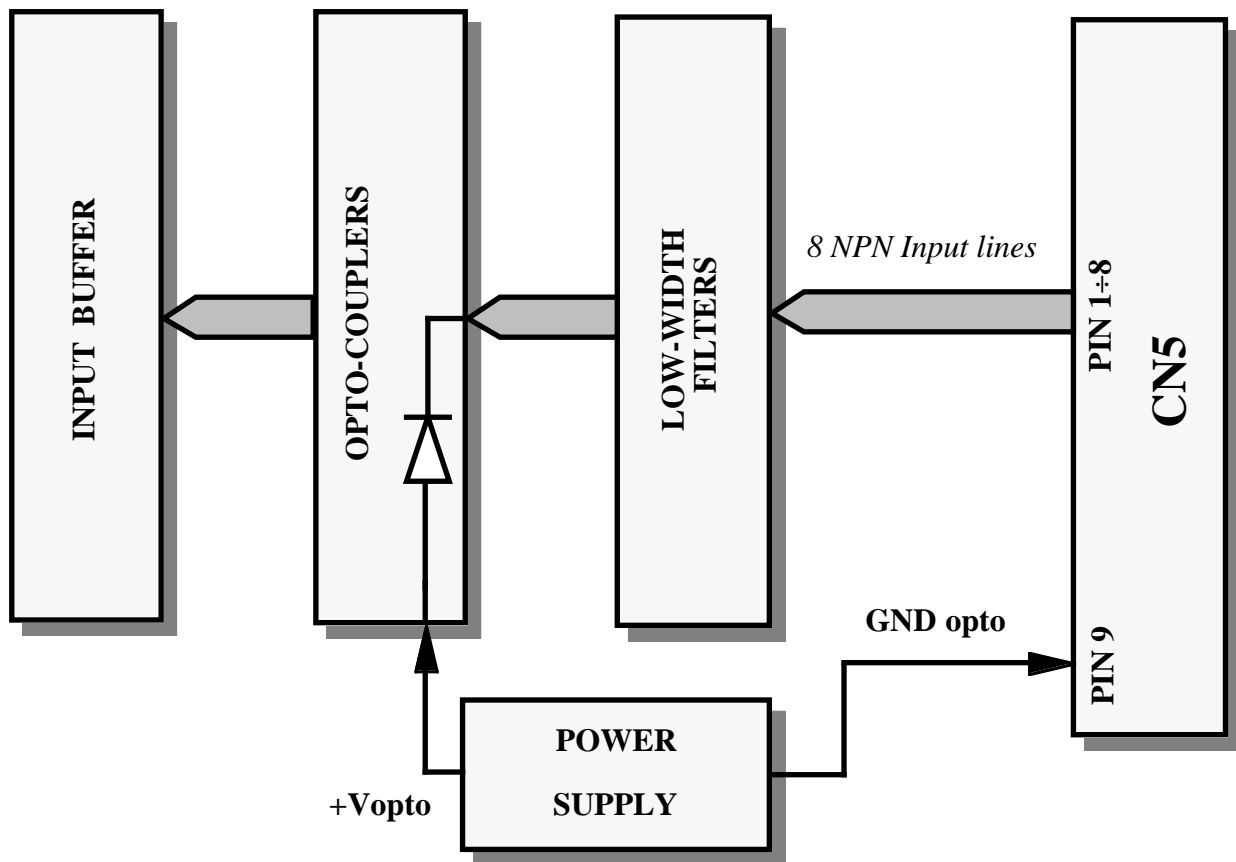

FIGURE 16: ZBT N88 OPTOCOUPLED NPN INPUT SECTION BLOCK DIAGRAM

## CN5 - ZBT P88 OPTOCOUPLED INPUTS CONNECTOR

CN5 is a 9 pins quick release screw terminal connector. By CN5 eight optocoupled **PNP** inputs of **ZBT P88** card can be connected to the external world, in particular the **IN1** inputs section. Open Collector PNP inputs and optocoupled section supply common terminal are present.

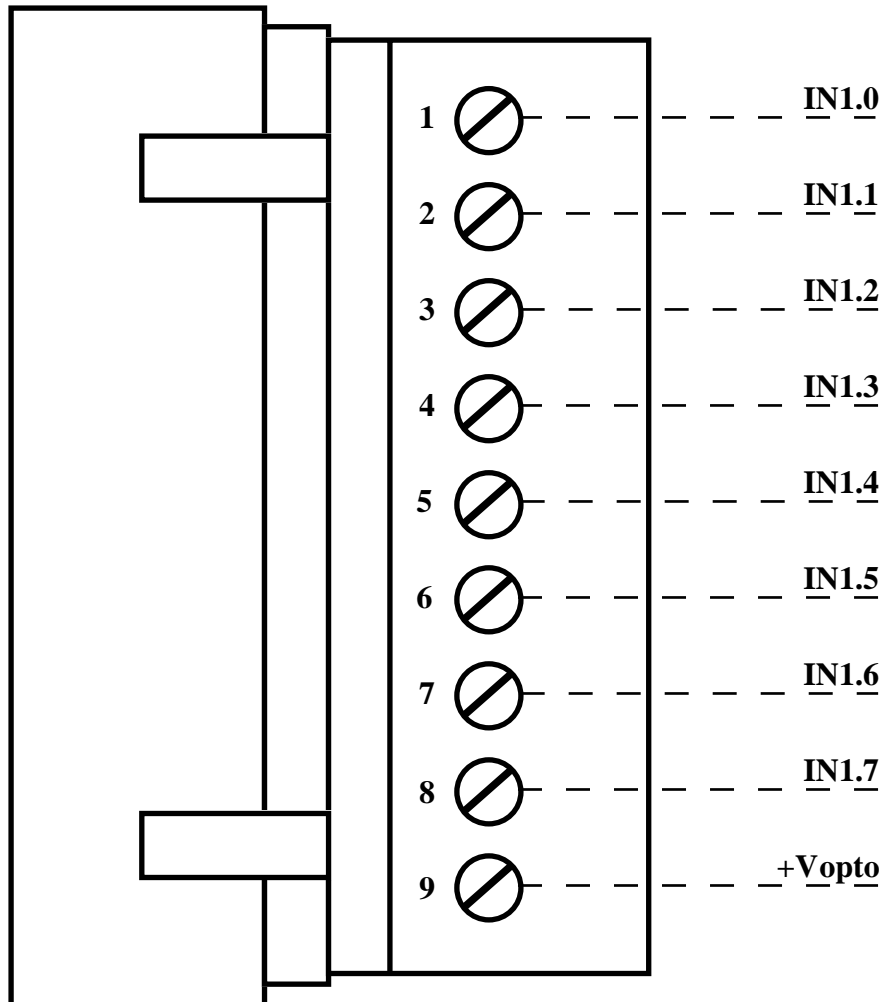

FIGURE 17: CN5 - ZBT P88 OPTOCOUPLED PNP INPUTS CONNECTOR

Signals description:

**IN1.n** = I - PNP Open Collector input connected to IN1 section  
**+Vopto** = - Supply terminal of Optocoupled inputs

The PNP input signals available on **ZBT P88** are Optocoupled to warrant a high degree of protection for on board electronics against noise and disturbs from the external world.

Each signal is provided with a LED for visual feed back (the LED will light whenever the input will have the potential of +Vopto signal); this means that the inputs are going to support normally open contacts

The interface circuitry for this input section is shown in the following diagram.

The Optocouplers power supply is generated by on board power supply or, if the **ZBT P88** board is not provided with power supply circuitry, must be provided through the specific connector CN3.

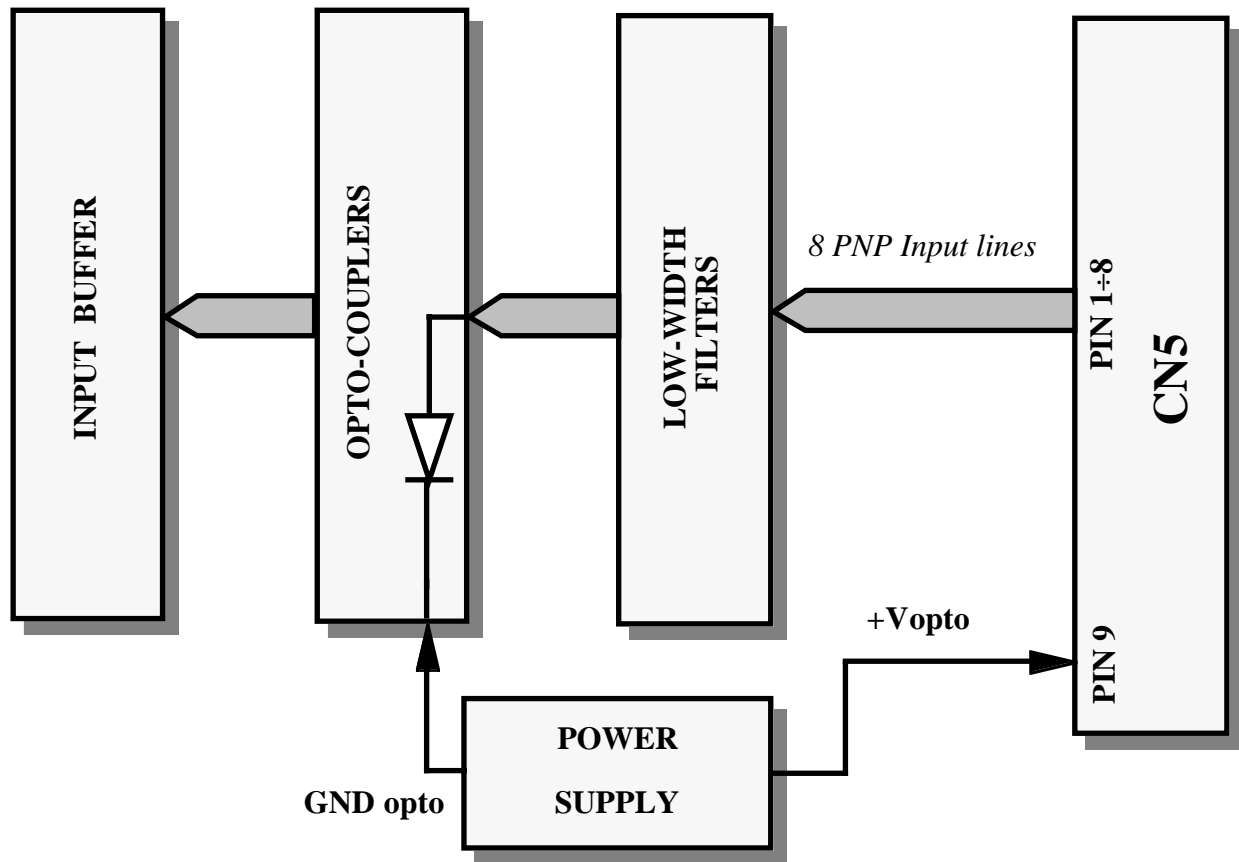

FIGURE 18: ZBT P88 OPTOCOUPLED PNP INPUT SECTION BLOCK DIAGRAM

## CN6 - ZBT N88 NPN TRANSISTOR OUTPUT CONNECTOR

On **ZBT N88** card, CN6 is a 12 pins quick release screw terminal connector. By CN6 eight **NPN** Darlington transistor outputs can be connected to the external world, in particular the **OUT1** outputs section. Open collector signals of each NPN transistor output and three common terminals (emitter) related to all the eight outputs are present; in addition there is a pin to connect to the load power supply voltage, to discharge any eventual inductive tension.

Please remark that the maximum current for each transistor is 4 A non continuous.

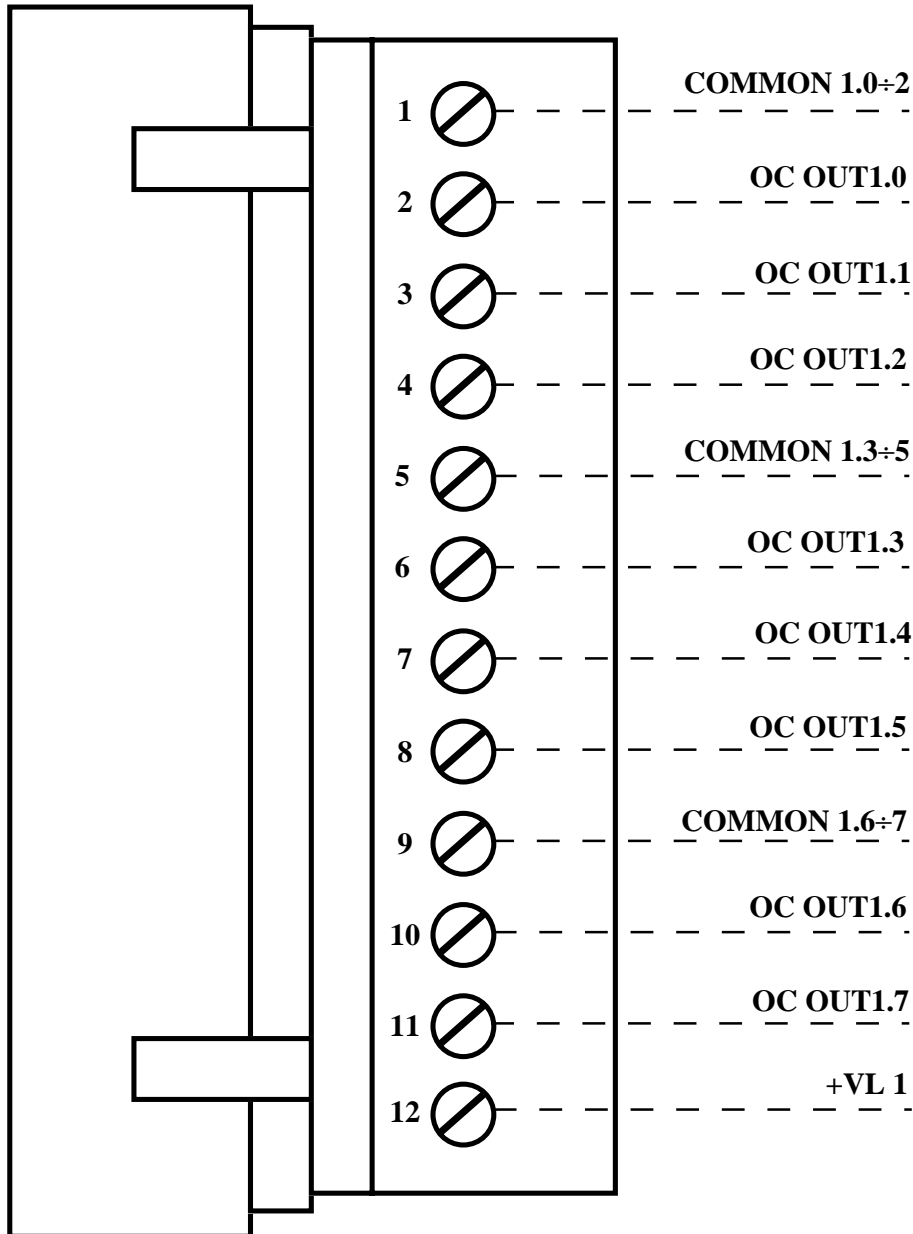

FIGURE 19: CN6 - ZBT N88 NPN TRANSISTOR OUTPUT CONNECTOR

Signals description:

- COMMON 1.x÷y** = - Negative Common emitter of OUT1 transistors from x to y  
**NO OUT 1.n** = O - Open collector contact of n-th OUT1 NPN transistor output  
**+VL 1** = I - Load power supply voltage pin (+45 Vdc max)  
 It is also the common point for back EMF protection diods

The NPN Darlington transistor output signals available on **ZBT N88** are provided with a LED for visual feed back (the LED will light whenever the transistor is ON); they are optocoupled to warrant galvanical isolation between on board electronics and the external world

The final stage of these outputs is made by a **NPN Open Collector Darlington transistor**, capable to bear a maximum current of **4 A non continuous**, with a maximum tension that can be **+45 Vdc**.

This component, lacking the heat sink, can drive continuously a resistive load that, supplied with a tension of **24 Vdc**, consumes a maximum current of **600 mA**; these figures are valid only if environmental temperature is 20 Centigrad degrees.

It is remarkable that the current status of output signal can be acquired by software to simplify the application software development.

The interface circuitry for NPN transistors output section is shown in the following diagram.

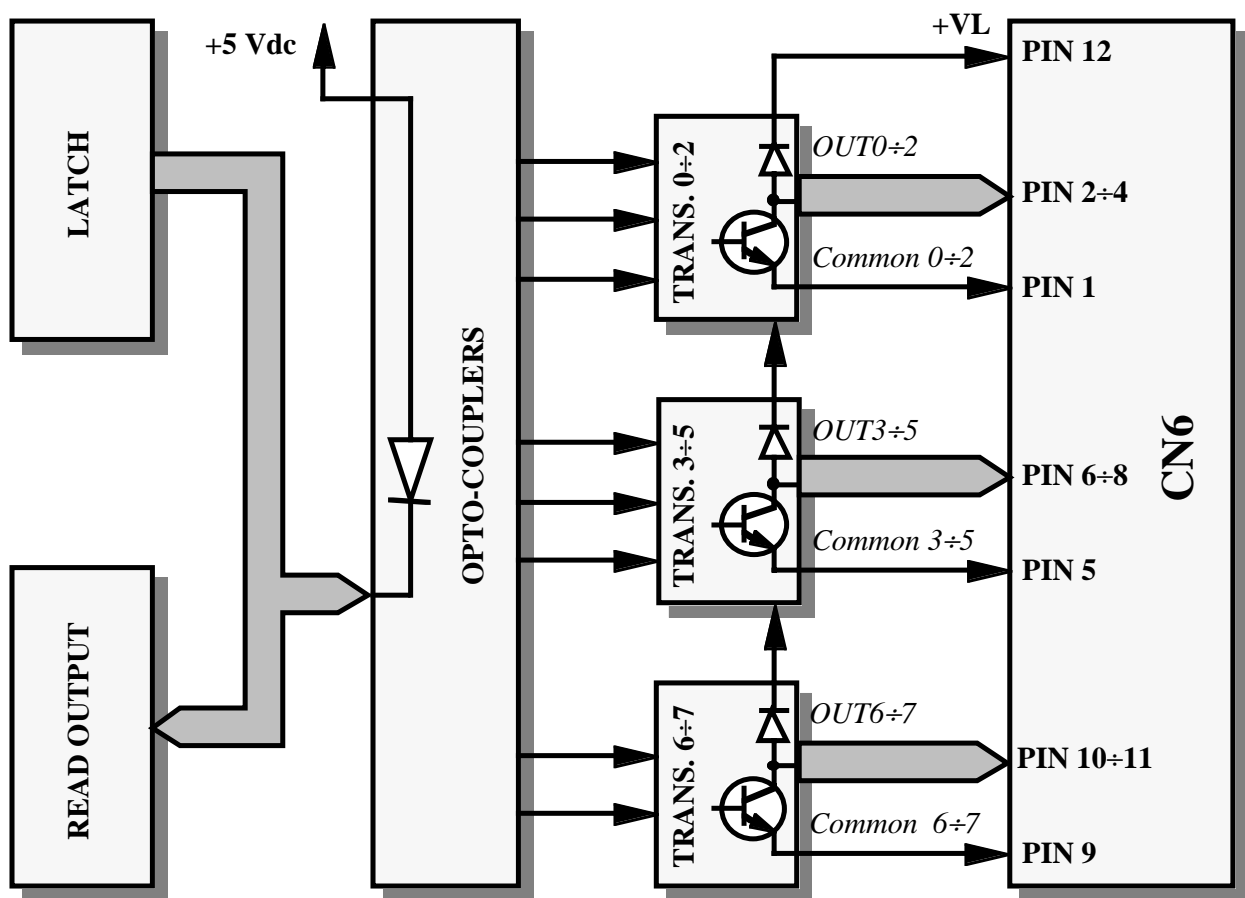

FIGURE 20: ZBT N88 NPN TRANSISTOR OUTPUT BLOCK DIAGRAM

### CN6 - ZBT P88 PNP TRANSISTOR OUTPUT CONNECTOR

On **ZBT P88** card, CN6 is a 12 pins quick release screw terminal connector. By CN6 eight **PNP** Darlington transistor outputs can be connected to the external world, in particular the **OUT1** outputs section. Open collector signals of each PNP transistor output and three common terminals (emitter) related to all the eight outputs are present; in addition there is a pin to connect to the load power supply voltage, to discharge any eventual inductive tension.

Please remark that the maximum current for each transistor is 4 A non continuous.

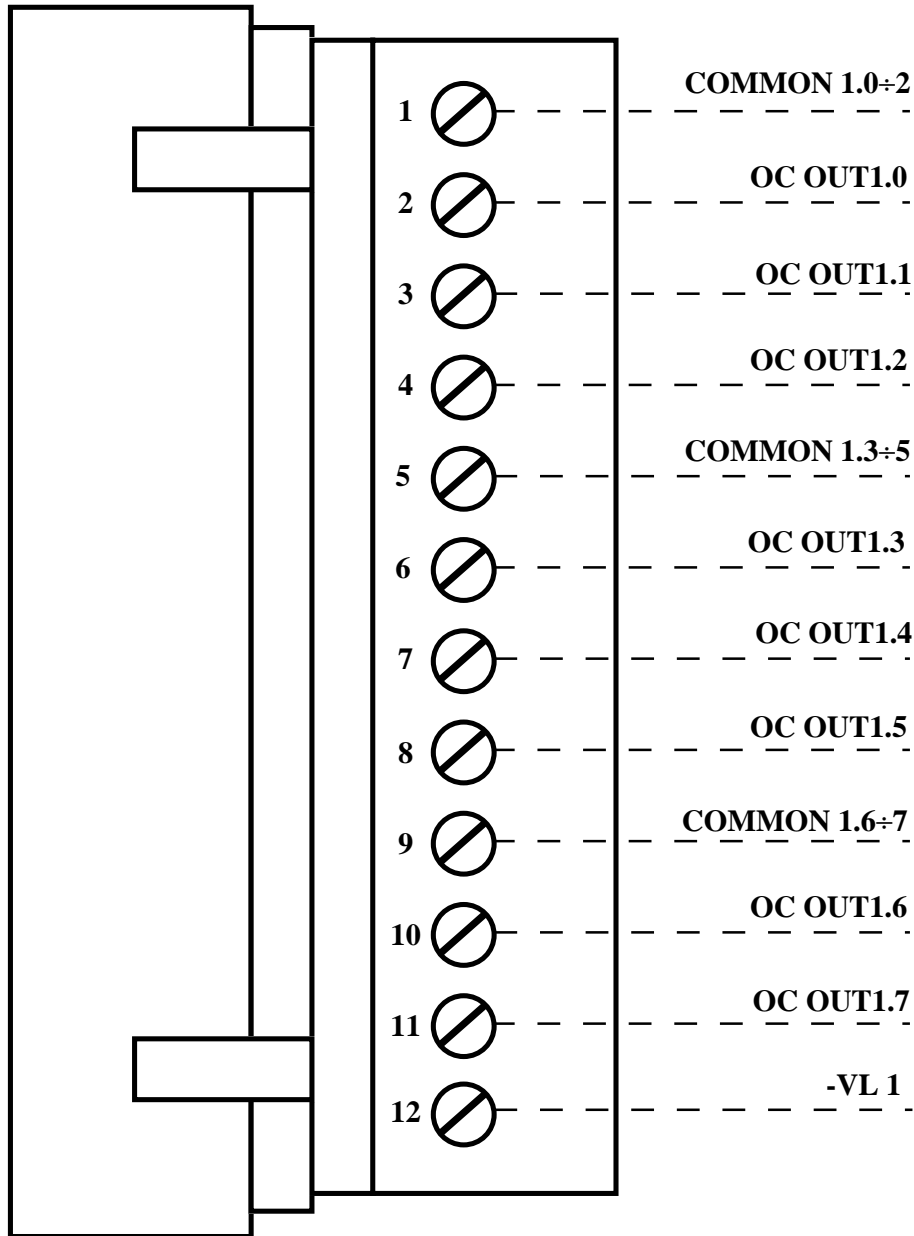

FIGURE 21: CN6 - ZBT P88 PNP TRANSISTOR OUTPUT CONNECTOR

Signals description:

- COMMON 1.x÷y** = I - Positive Common emitter OUT1 transistors from x to y (+45 Vdc max)
- NO OUT 1.n** = O - Open collector contact of n-th OUT1 PNP transistor output
- VL 1** = - Load power supply voltage pin  
It is also the common point for back EMF protection diods

The PNP Darlington transistor output signals available on **ZBT P88** are provided with a LED for visual feed back (the LED will light whenever the transistor is ON); they are optocoupled to warrant galvanical isolation between on board electronics and the external world

The final stage of these outputs is made by a **PNP** Open Collector Darlington transistor, capable to bear a maximum current of **4 A non continuous**, with a maximum tension that can be **+45 Vdc**.

This component, lacking the heat sink, can drive continuously a resistive load that, supplied with a tension of **24 Vdc**, consumes a maximum current of **600 mA**; these figures are valid only if environmental temperature is 20 Centigrad degrees.

It is remarkable that the current status of output signal can be acquired by software to simplify the application software development.

The interface circuitry for PNP transistors output section is shown in the following diagram.

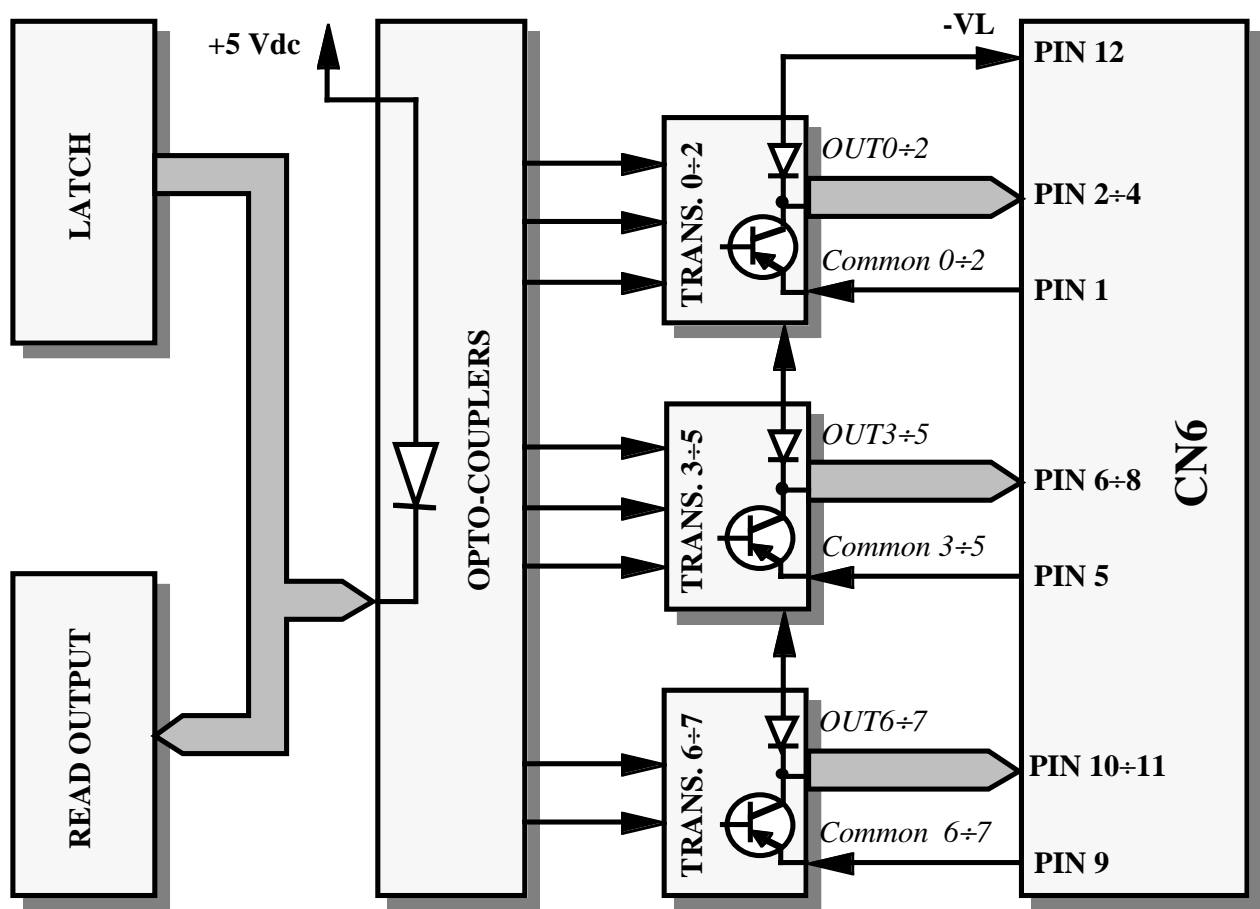

FIGURE 22: ZBT P88 PNP TRANSISTOR OUTPUT BLOCK DIAGRAM

## VISUAL SIGNALATIONS

**ZBT N88** and **ZBT P88** cards are provided with signalation LEDs to show several status informations, as described in the following table:

LEDS	COLOUR	FUNCTION
LD11÷LD18	Green on <b>ZBT N88</b> Yellow on <b>ZBT P88</b>	They show the status of IN1 optocoupled eight input signals, respectively IN1.0÷IN1.7. LED ON means contact closed.
LD51÷LD58	Red	They show the status of OUT1 eight output signals, respectively OUT1.0÷7. LED ON means output active (transistor conducting).
LD1	Green	It signals the presence of +Vopto optocouplers power supply voltage.
LD4	Yellow	It shows the status of optocouled line interfaced to /NMI signal. LED ON means input contact closed.
LD5	Green	It shows the status of optocouled line interfaced to /INT signal. LED ON means input contact closed.
LD3	Red	It signals the presence of +5 Vcc power supplt voltage.

**FIGURE 23: VISUAL SIGNALATIONS TABLE**

The main purpose of LEDs is to show a visual indication about the card's status, making so easier debug and verify operations.

To easily locate these visual signalations please refer to the figure, in the following pages, related to the **ZBT N88** or **ZBT P88** card being used.

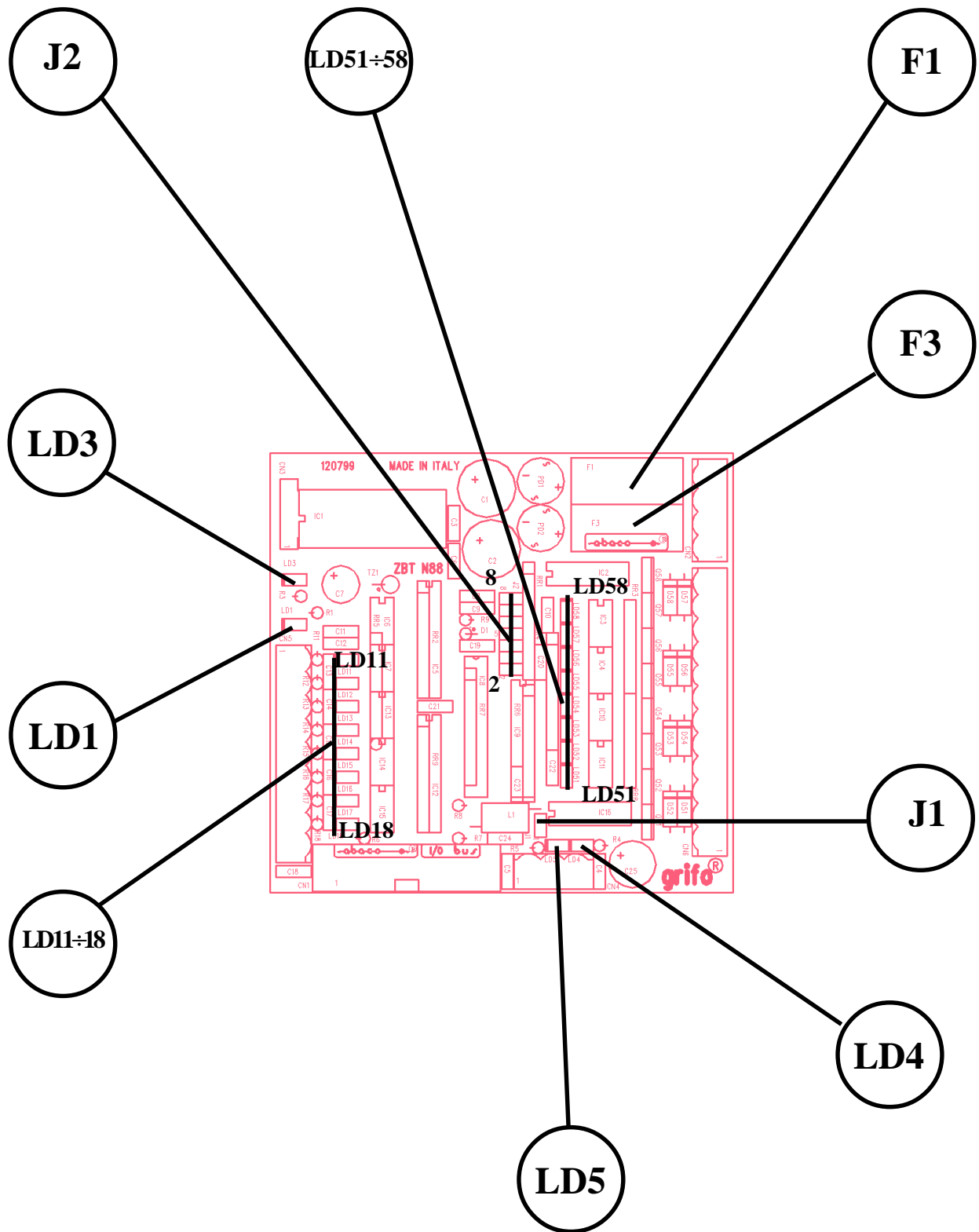

FIGURE 24: ZBT N88 LEDs, JUMPERS AND FUSES LOCATION

## JUMPERS

On **ZBT N88** and **ZBT P88** boards there are 2 jumpers for card configuration. Below there is the jumpers list, location and function.

JUMPERS	N. PINS	USE
J1	2	It select the connection of +5 Vdc on <b>ABACO</b> <sup>®</sup> I/O BUS connector.
J2	14	It selects the address of the board in the <b>ABACO</b> <sup>®</sup> I/O BUS addressing space.

**FIGURE 25: JUMPERS SUMMARIZING TABLE**

The following tables describe all the right connections of the three jumpers with their relative functions. For recognizing jumpers location, please refer to the figure, in the following pages, that is related to the card being used.

## 2 PINS JUMPERS

JUMPER	CONNECTION	USE	DEF.
J1	not connected	It does not connect the +5 Vdc supply voltage, generated by the on board circuitry, to the <b>ABACO</b> <sup>®</sup> I/O BUS connector.	*
	connected	It connects the +5 Vdc supply voltage, generated by the on board circuitry, to the <b>ABACO</b> <sup>®</sup> I/O BUS connector. This way it is possible to supply an eventual control card.	

**FIGURE 26: 2 PINS JUMPERS SUMMARIZING TABLE**

The "\*" used in the following tables, denotes the default connection, or on the other hand the connection set up at the end of testing phase, that is the configuration the user receives.

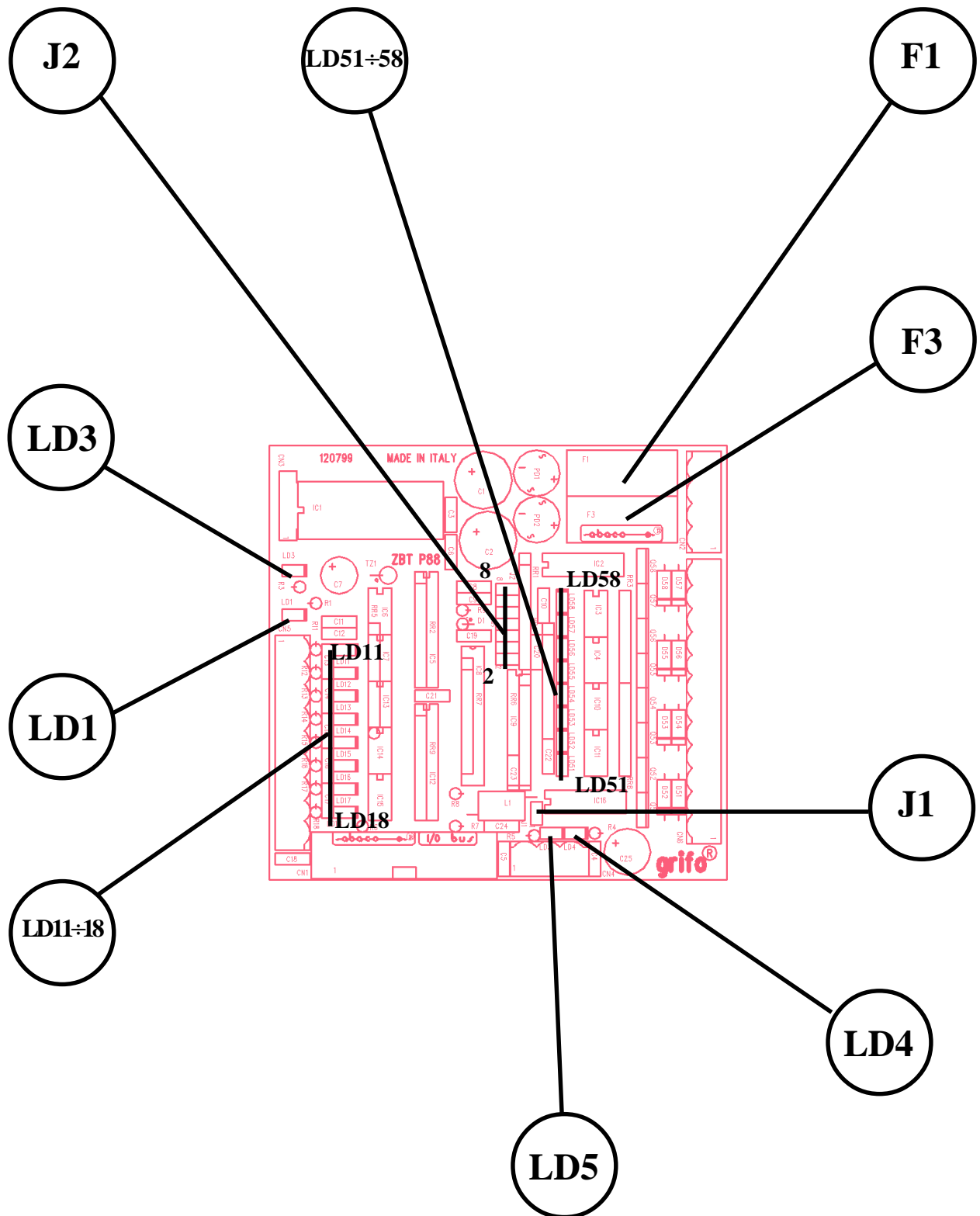

FIGURE 27: ZBT P88 LEDs, JUMPERS AND FUSES LOCATION

## 14 PINS ADDRESSING JUMPER

Through jumper **J2** it is possible to select the address of the board in the **ABACO® I/O BUS** addressing space. It features **7x2** pins (JAddr.2÷JAddr.8).

Here follows a table with the possible configurations, while the mapping configurations are explained in the paragraph dedicated to the board mapping.

JUMPER	CONNECTION	USE	DEF.
JAddr.2	not connected	Sets A1 of mapping address to logic "1"	*
	connected	Sets A1 of mapping address to logic "0"	
JAddr.3	not connected	Sets A2 of mapping address to logic "1"	*
	connected	Sets A2 of mapping address to logic "0"	
JAddr.4	not connected	Sets A3 of mapping address to logic "1"	*
	connected	Sets A3 of mapping address to logic "0"	
JAddr.5	not connected	Sets A4 of mapping address to logic "1"	*
	connected	Sets A4 of mapping address to logic "0"	
JAddr.6	not connected	Sets A5 of mapping address to logic "1"	*
	connected	Sets A5 of mapping address to logic "0"	
JAddr.7	not connected	Sets A6 of mapping address to logic "1"	*
	connected	Sets A6 of mapping address to logic "0"	
JAddr.8	not connected	Sets A7 of mapping address to logic "1"	*
	connected	Sets A7 of mapping address to logic "0"	

**FIGURE 28: ADDRESSING JUMPERS TABLE**

The "\*" used in the following tables, denotes the default connection, or on the other hand the connection set up at the end of testing phase, that is the configuration the user receives.

## I/O CONNECTIONS

To prevent possible connecting problems between **ZBT N88** and **ZBT P88** boards and the external systems, the User has to read carefully the information of the previous paragraphs and he must follow these instructions:

- To connect to the optocoupled input signals, only the contacts to acquire must be connected from the external system(s). These contacts (relays, switches, etc.) must connect or not connect the input signal IN1.y to GND opto on **ZBT N88** or +Vopto on **ZBT P88**.

About the correspondance between logic signals and contact status, remember that a contact open generates a logic **1**, while a contact closed generates a logic **0**.

- To connect to the optocoupled /NMI and /INT input signals, only the contacts to acquire must be connected from the external system(s). These contacts (relays, switches, etc.) must connect or not connect the input signal to GND opto on **ZBT N88** or +Vopto on **ZBT P88**.

About the correspondance between logic signals and contact status, remember that only a contact closed generates an interrupt request.

- The Darlington transistor output signals, **NPN** on **ZBT N88** or **PNP** on **ZBT P88**, must be connected directly to the load to drive (power relays, etc.). The board provides the Open Collector OC OUT1.y output signal, capable to bear a maximum current of **4 A non countonuous** with a tension that can be **+45 Vdc**.

The transistors, lacking the heat sink, can drive continuously a restitive load that, supplied with a tension of **24 Vdc**, consumpts a maximum current of **600 mA**; these figures are valid only if environmental temperature is 20 Centigrad degreeses.

## SUPPLY VOLTAGES SELECTION

**ZBT N88** and **ZBT P88** cards are provided with an efficent power supply circuitry that is designed to solve in a comfortable way the problem to supply the system despite the condition of utilization. The boards power supply section includes: a switching that provides the corrent voltage on +5 Vdc in any admitted condition of load and input tension; a simple rectifier group that generates +Vopto voltage suitable to supply the optocupled input sections.

Here follow the two possible configurations of supply section:

-Low voltage power supply

In this configuration the board requires two 15÷18 Vac or 18÷24 Vdc galvanically isolated tensions (normally available in control machines electric racks) that must be provided on 4 pins CN2 connector. The board generates in autonomy the +5 Vdc and +Vopto keeping them galvanically isolated. Supported external loads depend on the kind of **ZBT N88** or **ZBT P88** card being used and are reported in the chapters about techncal features.

Such data imply that, of course, the two external are enough to supply also externa loads.

- Stabilized power supply

In this configuration the board has no power supply section. The +5 Vdc and +Vopto voltages must be provided by an external source through CN3 connector.

Available voltages and acceptable powers are exactly the ones provided on this connector by the external power supply.

Please remark that +Vopto voltage has a nominal value of +24 Vdc but being generated by a not stabilized rectifier section it may vary heavily. For this motivation across the whole manual the current value has never been reported, instead the value of power has been reported.

Interfacing systems through **ABACO® I/O BUS** external cards featuring their own power supply section (**GPC® 15R**, **ABB 05**, series **3** and **4**) may supply the **ZBT N88** or **ZBT P88** card through this BUS. In such case the +5 Vdc supply voltage must be provided through the specific connector (CN3); only after a careful verification of powers involved and external working conditions the +5 Vdc voltage can be provided directly to the CN1 **ABACO® I/O BUS** connector.

In case of doubts about which power supply section to choose and the connections to perform, please contact **grifo®**.

This need must be specified in the order, in fact this implies a different hardware configuration that must be performed by **grifo®** technicians.

## HARDWARE DESCRIPTION

### INTRODUCTION

This chapter provides all the hardware informations needed to use **ZBT N88** and **ZBT P88** boards. Here the User will find informations about I/O card mapping and on board peripheral devices addressing.

### BOARD MAPPING

**ZBT N88** and **ZBT P88** boards are mapped into a 2 bytes I/O addressing space. These bytes can be mapped starting from different base addresses according to how the board is configured. This feature allows to use several **ZBT N88** and **ZBT P88** cards on the same **ABACO® I/O BUS**, or to install them on a BUS where other peripheral modules are installed obtaining a structure that can be expanded without any difficulty or modifications to the application software.

The base address can be defined through the specific BUS interface circuitry on the board itself; this circuitry uses the jumpers group called **J2**, described in the previous chapter, from which it reads the address set by the User. Here follows the corrispondance between jumpers configuration and address signals.

J2.2	->	A1 address signal
J2.3	->	A2 address signal
J2.4	->	A3 address signal
J2.5	->	A4 address signal
J2.6	->	A5 address signal
J2.7	->	A6 address signal
J2.8	->	A7 address signal

These jumpers are driven in complemented logic, this means that if a jumper is **CONNECTED** generates a **logic zero**, viceversa if a jumper is **NOT CONNECTED** generates a **logic one**.

About jumpers location, please refer to the figure referring to the **ZBT N88** or **ZBT P88** card being used.

Here follow some examples of mapping:

1) If the User wants to map a **ZBT N88** or **ZBT P88** starting from the address <baseaddr>=088H, then he/she will have to configure the board as follows:

J2.2	->	Connected
J2.3	->	Connected
J2.4	->	Not Connected
J2.5	->	Connected
J2.6	->	Connected
J2.7	->	Connected
J2.8	->	Not Connected

2) If the User wants to map a **ZBT N88** or **ZBT P88** starting from the address <baseaddr>=020H, then he/she will have to configure the board as follows:

J2.2 -> Connected  
 J2.3 -> Connected  
 J2.4 -> Connected  
 J2.5 -> Connected  
 J2.6 -> Not Connected  
 J2.7 -> Connected  
 J2.8 -> Connected

### **INTERNAL REGISTERS ADDRESSING**

Indicating the board base address with <baseaddr>, that is the address set using the **J2** jumpers, as indicated in the previous paragraph, **ZBT N88** and **ZBT P88** internal registers are addressable as explained in the following tables.

#### **NOTE**

If using several boards on the same **ABACO® I/O BUS**, when setting the boards mapping address the User should be careful not to allocate more than one board in the same addressing space (consider the base address plus the bytes taken by the board addressing). If this condition is not satisfied a **BUS** conflict situation will occur, prejudicing the correct working of the whole system.

<b>DEVICE</b>	<b>REG.</b>	<b>ADDRESS</b>	<b>R/W</b>	<b>MEANING</b>
<b>OUTPUT 1</b>	OUT1	<baseaddr>+00H	R/W	OUT1 eight outputs section setting and acquisition register.
<b>INPUT 1</b>	IN1	<baseaddr>+01H	R	IN1 eight optocoupled inputs section acquisition register.

**FIGURE 29: ZBT N88 AND ZBT P88 INTERNAL REGISTERS ADDRESSING TABLE**

## PERIPHERAL DEVICES SOFTWARE DESCRIPTION

In the previous paragraph allocation addresses of all the peripherals have been reported, here follows a detailed description of function and meaning of internal registers (please always refer to the peripheral mapping tables to understand completely the following informations). Should the present documentaion be inadequate please refer to the component's manufacturer documentation.

### TRANSISTOR OUTPUTS

Input/Output register OUT1 is used to perform the output management on **ZBT N88** and **ZBT P88** boards. The 8 bits of these registers have the following meaning:

D7	->	OC OUT1.7
D6	->	OC OUT1.6
D5	->	OC OUT1.5
D4	->	OC OUT1.4
D3	->	OC OUT1.3
D2	->	OC OUT1.2
D1	->	OC OUT1.1
D0	->	OC OUT1.0

The indication **OC OUT1.?** stands for OUT1 section, whose output signals are available on connector CN6.

Performing an output operation at the address of OUT1 the corresponding eight outputs are set by the output data, while performing an input operation at the same address the status of the corresponding signals is input.

The correspondance between status of an output and value of a bit is:

Bit at logic 0	->	Output disabled	=	Transistor disabled
Bit at logic 1	->	Output enabled	=	Transistor enabled

The possibility to read the outputs status is very intresting; in fact in every moment and in any condition the application program can check the status of the outputs and modify it according to its policy. OUT1 register is reset (all bits are 0) when a Reset or a Power On occur, this disables all the outputs and all transistors are disabled.

## OPTOCOUPLED INPUTS

Input register IN1 is used to perform the input management on **ZBT N88** and **ZBT P88** boards. The 8 bits of these registers have the following meaning:

D7	->	IN1.7
D6	->	IN1.6
D5	->	IN1.5
D4	->	IN1.4
D3	->	IN1.3
D2	->	IN1.2
D1	->	IN1.1
D0	->	IN1.0

The indication **IN1.?** stands for IN1 section, whose input signals are available on connector CN5. Performing an input operation at the address of IN1 the corresponding eight optocoupled input signals are acquired.

The correspondance between status of an input and value of a bit is:

Bit at logic 1	->	Input disabled	=	Input contact open
Bit at logic 0	->	Input enabled	=	Input contact closed

## EXTERNAL CARDS

**ZBT N88** and **ZBT P88** boards can interface to most of **grifo®** industrial boards. Their main purpose is to perform a digital Input/Output interfacement between CPU (**GPC®**) cards and the external world. The on board power supply section is often enough to supply all the card electronics, but in case of need most of **grifo®** power supplies can be easily used.

Here is reported an illustrative list of cards capable to supply **ZBT N88** and **ZBT P88** boards with a short description of their features; for further informations please request the specific documentation.

### **SBP 01-xx**

Switch BLOCK Power xx version

Switching power suppliers able to generate voltage from -12 to +40 Vdc and current up to 4A. Input from 12 to 26 Vac; battery backed; power good; quick connection for DIN 46277-1 and 3 rails.

### **SBP 02-xx**

Switch BLOCK Power xx version

Low cost switching power supply able to generate voltage from +5 to +40 Vdc and current up to 2,5 A; Input from 12 to 24 Vac; Connection for DIN C Type and  $\Omega$  rails.

### **SBP 05-xx**

Switch BLOCK Power xx version

Low cost switching power supply able to generate voltage from +5 to +40 Vdc and current up to 6÷10 A; Input from 12 to 24 Vac; Battery backed input; Connection for DIN C Type and  $\Omega$  rails.

### **PCC A26**

P.C. Centronics <-> **Abaco®** I/O BUS adapter

Adapter card between standard PC centronics interface and **Abaco®** I/O BUS connectors; all **Abaco®** peripheral cards can be driven; wide range of software drivers (Pascal, C++, Basic, etc.); interrupt management; 256 bytes of address space; plastic box; direct connection to any PC.

### **GPC® 188F**

General Purpose Controller 80C188

80C188  $\mu$ P 20MHz; 1 RS 232 line; 1 RS 232, RS 422-485 or Current Loop line; 24 TTL I/O lines; 1MEPROM or 512K FLASH; 1M RAM Lithium battery backed; 8K serial EEPROM; RTC; Watch Dog; 8 Dip switch; 3 Timer Counter; 8 13 bit A/D lines; Power failure; activity LEDs; single power supply +5Vdc.

**GPC® 15A**

## General Purpose Controller 84C15

Full CMOS card, 10÷20 MHz 84C15 CPU; 512K EPROM or FLASH; 128K RAM; 8K RAM and RTC backed; 8K serial EEPROM; 1 RS 232 line; 1 RS 232 line or RS 422-485 or Current Loop line; 32 or 40 TTL I/O lines; CTC; Watch dog; 2 Dip switches; Buzzer.

**GPC® 15R**

## General Purpose Controller 84C15

84C15  $\mu$ P, 10÷16 MHz; 1 RS 232 line; 1 RS 232 or RS 422-485 or C. L. line; 16÷24 TTL I/O lines; 16 Opto-in; 8 Relays; 4 Opto Coupled Timers Counters; 512K EPROM or FLASH; 512K RAM and RTC backed; 8K serial EEPROM; 8K Backed RAM modul; Buzzer; 1 Activity LED; Watch dog; 4÷12 readable DIPs; LCD Interface.

**GPC® 153**

## General Purpose Controller Z80

84C15  $\mu$ P, 10÷16 MHz; Full CMOS; 1 RS 232 line; 1 RS 232 or RS 422-485 or Current Loop line; 16 TTL I/O lines; 8 A/D 12 bits lines; 2÷4 Timers Counters; 512K EPROM or FLASH; 512K RAM and RTC backed; 8K serial EEPROM; Buzzer; 1 Activity LED; Watch dog; 8 readable DIPs; LCD Interface.

**GPC® 323**

## General Purpose Controller 51 family

80C32  $\mu$ P, 14 MHz; Full CMOS; 1 RS 232 line (software); 1 RS 232 or RS 422-485 or Current Loop line; 24 TTL I/O lines; 11 A/D 12 bits lines; 3 Timers Counters; 64K EPROM; 64K RAM; 32K RAM and RTC backed; 32K DIL EEPROM; 8K serial EEPROM; Buzzer; 2 Activity LED; Watch dog; 5 readable DIPs; LCD Interface.

**GPC® 553**

## General Purpose Controller 80C552

80C552  $\mu$ P, 22÷33 MHz; 1 RS 232 line (software); 1 RS 232 or RS 422-485 or Current Loop line; 16 TTL I/O lines; 8 A/D 10 bits lines; 3 Timers Counters; 64K EPROM; 64K RAM; 32K RAM and RTC backed; 32K DIL EEPROM; 8K serial EEPROM; 2 PWM lines; 1 Activity LED; Watch dog; 5 readable DIPs; LCD Interface.

**GPC® 183**

## General Purpose Controller Z180

Z180  $\mu$ P, 10÷16 MHz; Full CMOS; 1 RS 232 line; 1 RS 232 or RS 422-485 or Current Loop line; 24 TTL I/O lines; 11 A/D 12 bits lines; 2 Timers Counters; 512K EPROM or FLASH; 512K RAM and RTC backed; 8K serial EEPROM; Buzzer; 2 Activity LED; Watch dog; 4 readable DIPs; LCD Interface.

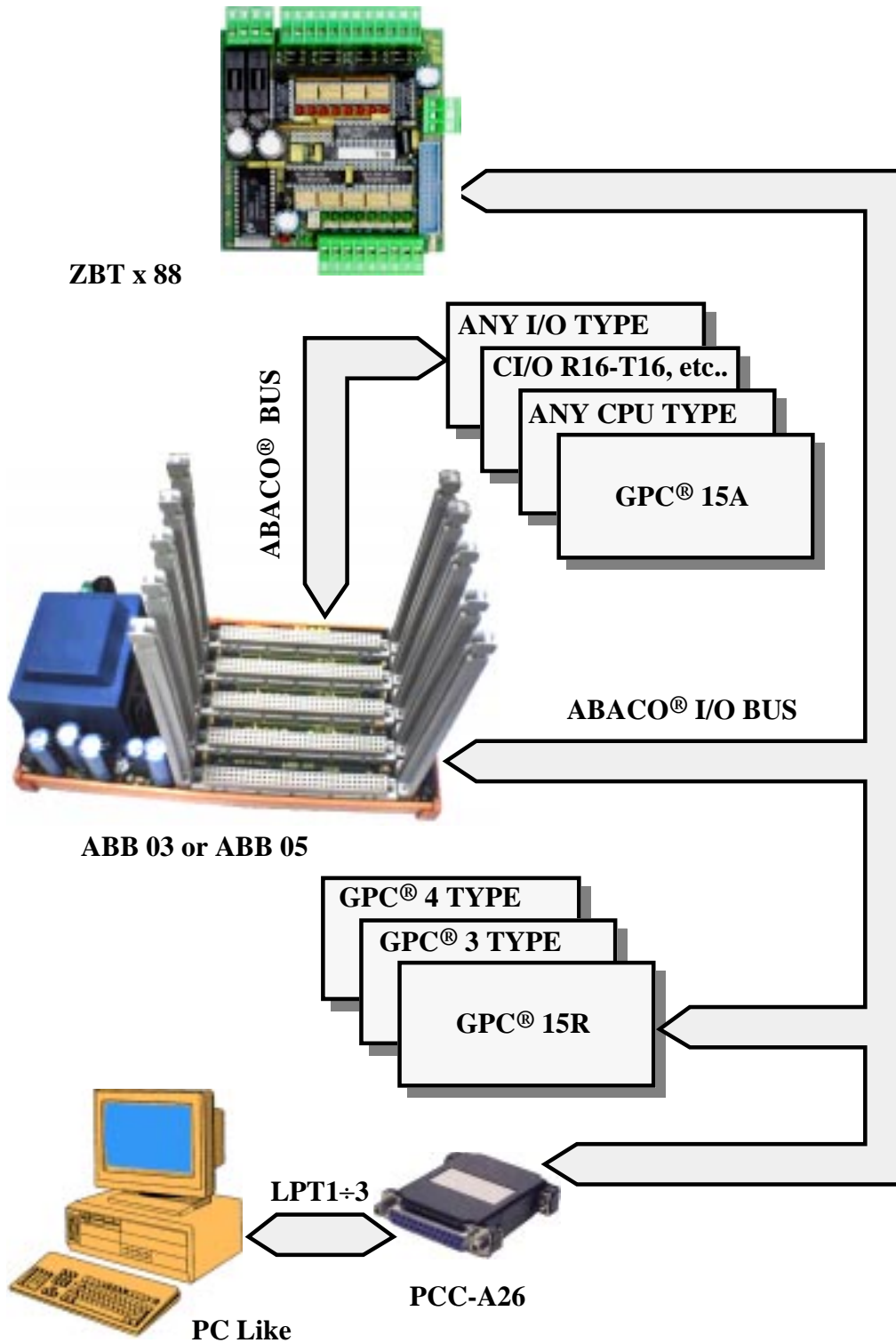

**ZBx Interconnections Blocks Diagram**

FIGURE 30: EXTERNAL CONNECTIONS DIAGRAM

**NOTE**

Please always remind that **ABACO® I/O BUS** is not a multimaster BUS. In other words, on the BUS one and only one CPU master card can be present.

**GPC® 154**

“4” Type General Purpose Controller Z80

84C15  $\mu$ P, 10÷16 MHz; Full CMOS; 1 RS 232 line; 1 RS 232 or RS 422-485 line; 16 TTL I/O lines; 2÷4 Timers Counters; 512K EPROM or FLASH; 512K RAM and RTC backed; 8K serial EEPROM; Watch dog; 2 readable DIPs; LCD Interface; Abaco® I/O BUS; 5Vdc Power supply; Size: 100x50 mm.

**GPC® 554**

“4” Type General Purpose Controller 80C552

80C552  $\mu$ P, 22 MHz; 1 RS 232 line (software); 1 RS 232 line; 16 TTL I/O lines; 8 A/D 10 bits lines; 3 Timers Counters; 64K EPROM; 64K RAM; 32K backed RAM; 32K DIL EEPROM; 8K serial EEPROM; 2 PWM lines; Watch dog; 3 readable DIPs; LCD Interface; Abaco® I/O BUS; 5Vdc Power supply; Size: 100x50 mm.

**GPC® 184**

“4” Type General Purpose Controller Z180

Z180  $\mu$ P, 10÷16 MHz; Full CMOS; 1 RS 232 line; 1 RS 232 or RS 422-485 or Current Loop line; 2 Timers Counters; 512K EPROM or FLASH; 512K RAM and RTC backed; Watch dog; 1 readable DIP; LCD Interface; Abaco® I/O BUS; 5Vdc Power supply; Size: 100x50 mm.

**GPC® 324/D**

“4” Type General Purpose Controller 80C32/320

80C32 or 80C320  $\mu$ P, 14÷22 MHz; Full CMOS; 1 RS 232 line; 1 RS 232 or RS 422-485 or Current Loop line; 4÷16 TTL I/O lines; 3 Timers Counters; 64K EPROM; 64K RAM; 32K RAM backed; 32K DIL E2; 8K serial EEPROM; Watch dog; 1 readable DIP; LCD Interface; Abaco® I/O BUS; 5Vdc Power supply; Size: 100x50 mm.

**GPC® 114**

“4” Type General Purpose Controller 68HC11

68HC11  $\mu$ P, 8 MHz; Full CMOS; 1 RS 232 or RS 422-485 serial line; 10÷18 TTL I/O lines; 8 A/D 8 bits lines; 1÷3 Timers Counters; 32K EPROM; 32K RAM and RTC backed; 512 byte Internal DIL EEPROM; Watch dog; 1 readable DIP; LCD Interface; Abaco® I/O BUS; 5Vdc Power supply; Size: 100x50 mm.

**GPC® AM4**

“4” type General Purpose Controller AVR MEGA 103

ATMEGA103  $\mu$ P, 6 MHz; 128K FLASH EPROM; 32K RAM and RTC backed with lithium battery; 4K EEPROM; 16 TTL I/O lines; 8 A/D 10 bits lines; 3 Timers Counters able to generate PWM signals; RS 232, 422, 485, current loop serial line; Watch dog; 1 readable dip; Abaco® I/O BUS; ISP programming interface; 5Vdc power supply.

**ABB 05****Abaco® BLOCK BUS 5 slots**

5 slots **Abaco®** Mother Board with Power Supply. Double power supply built-in; 5Vdc 2,5A section for powering the on-board logic; second section at 24Vdc 400mA galvanically coupled, for the optocoupled input lines; Auxiliary connector for **Abaco® I/O BUS**; Housing with hooks for DIN Omega rails .

**ABB 03****Abaco® BLOCK BUS 3 slots**

3 slots **Abaco®** Mother Board; 4 TE pitch connectors; **ABACO® I/O BUS** connector; screw terminal for power supply; connection for DIN C Type and  $\Omega$  rails.

## BIBLIOGRAPHY

Here follows a list of manuals and technical notes that the User can read to acquire more informations about **ZBT N88** and **ZBT P88** boards.

SGS-THOMSON Manual: *Industrial and Computer Peripheral ICs - Data Book*

SGS-THOMSON Manual: *Small Signal Transistors - Data Book*

TEXAS INSTRUMENTS Manual: *The TTL data BooK - SN54/74 Families*

TOSHIBA Manual: *Photo Couplers - Data Book*

MOTOROLA Manual: *Bipolar Power Transistor Data*

## APPENDIX A: CARD MECHANICAL MOUNTING

**ZBT N88** e **ZBT P88** boards can be put in a plastic container whose code is 414487 typeRS/100 by Weidmuller for direct mounting on DIN 46277-1 and 3  $\Omega$  rails. This container must be ordered to **grifo®** as **BLOCK.x88** option.

These boards are also designed to be matched to **GPC®** serie 3 or 4 boards, made by **grifo®**, obtaining an unique and solid block.

To put one of these modules and a **ZBT N88** or **ZBT P88** in the same Weidmuller plastic container, the User should order to **grifo®** also the container extension (code **BLOCK.100.3T** for a serie 3 module or **BLOCK.100.4T** for a serie 4 module) and the 26 pins flat cable to connect the two boards (code **FLT 26+26 I/O**).

The following figure shows a **ZBT x88** and a **GPC®** serie 4 card in Weidmuller rail mounting.

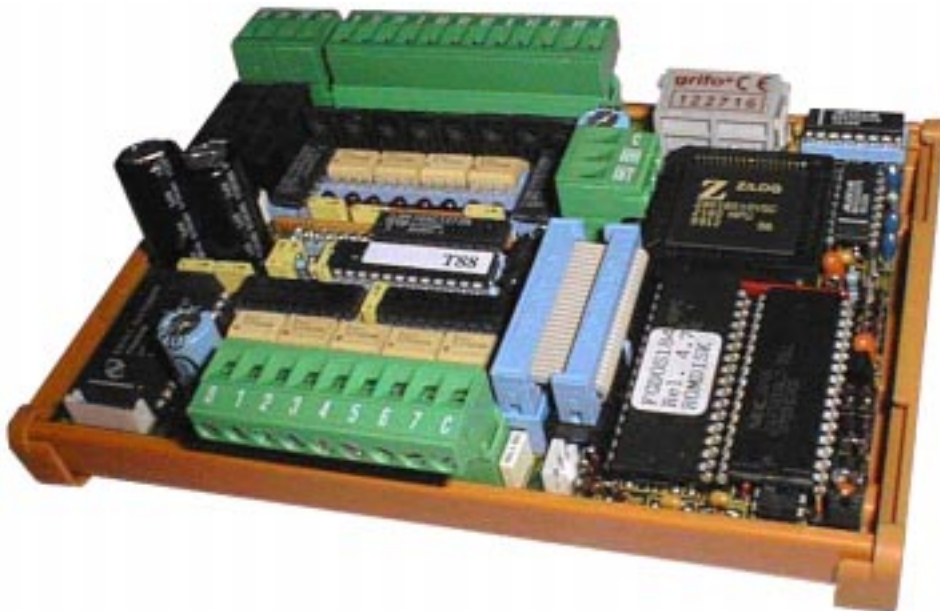

FIGURE A1: ZBT x88 AND A CPU SERIE 4 CARD IN WEIDMULLER RAIL MOUNTING



## APPENDIX B: ALPHABETICAL INDEX

### SYMBOLS

8 NPN OPEN COLLECTOR 4 A DARLINGTON TRANSISTOR OUT 2, 8  
8 NPN OPTOCOUPLED INPUTS 2, 8  
8 OPTOCOUPLED PNP INPUT 2, 10  
8 PNP OPEN COLLECTOR 4 A DARLINGTON TRANSISTOR OUT 2, 10

### B

BLOCK DIAGRAM 5  
BOARD MAPPING 35

### C

CARDS VERSIONS 2  
CONNECTIONS 12  
    CN1 13  
    CN2 14  
    CN3 12  
    CN4 16, 18  
    CN5 20, 22  
    CN6 24, 26

CONTROL LOGIC 6

### E

ELECTRIC FEATURES OF ZBT N88 8  
EXTERNAL CARDS 39

### G

GENERAL FEATURES 2  
GENERAL FEATURES OF ZBT N88 8  
GENERAL FEATURES OF ZBT P88 10

### H

HARDWARE DESCRIPTION 35

### I

I/O CONNECTIONS 33  
INPUT SECTION 4  
INSTALLATION 12  
INTERFACING AND ADDRESSING SECTION 6  
INTERFACING TO /INT AND /NMI SECTION 6  
INTERNAL REGISTERS ADDRESSING 36  
INTRODUCTION 1

### J

JUMPERS 30  
    14 PINS ADDRESSING JUMPER 32  
    2 PINS JUMPERS 30

**O**

OPTOCOUPLED INPUTS 38  
OUTPUT SECTION 4

**P**

PERIPHERAL DEVICES SOFTWARE DESCRIPTION 37  
PHYSICAL FEATURES OF ZBT N88 8  
POWER SUPPLY SECTION 6

**S**

SUPPLY VOLTAGES SELECTION 33

**T**

TECHNICAL FEATURES OF ZBT N88 8  
TECHNICAL FEATURES OF ZBT P88 10  
TRANSISTOR OUTPUTS 37

**V**

VISUAL SIGNALATIONS 28

**Z**

ZBT N88 CARD PHOTO 3  
ZBT N88 COMPONENTS MAP 9  
ZBT N88 CONNECTORS LOCATION 15  
ZBT P88 CONNECTORS LOCATION 15  
ZBT N88 LEDS, JUMPERS AND FUSES LOCATION 29  
ZBT P88 LEDS, JUMPERS AND FUSES LOCATION 31  
ZBT P88 CARD PHOTO 7  
ZBT P88 COMPONENTS MAP 11