

# MIAC-01

Now you are in control

- General purpose industrial controller
- Full graphical programming language supplied
- A wide variety of applications



English



Spanish



Greek



Thai



Dutch



French



Romanian



Finish



Italian



Vietnamese



German



Slovenian



Danish



Hungarian



Korean



Slovak



Mandarin



Turkish



Portuguese



Japanese

**MATRIX**

# Introduction

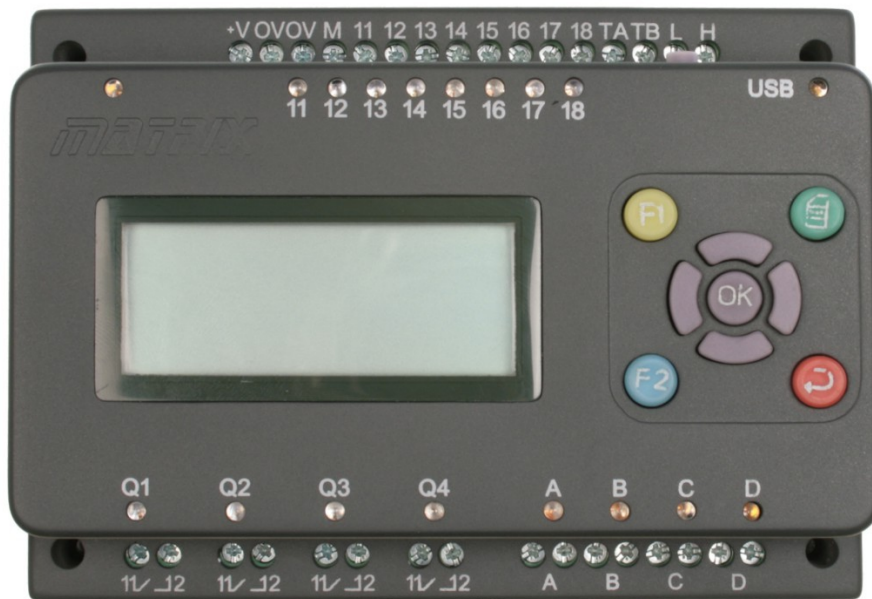

## What does it do?

MIAC (Matrix Industrial Automotive Controller) is an industrial grade control unit which can be used to control a wide range of different electronic systems. It has a number of applications in industry and learning.

## Benefits

- Flexible and expandable
- Easy to program with flowcharts, C or Assembly code
- Physically and electrically rugged

## Features

- Programmable from USB
- Shipped with a free copy of Flowcode
- Compatible with third party C compilers
- 8 digital or analogue inputs
- 4 relay outputs, 4 motor outputs with speed control
- 4 line LCD display and control keys
- Lab View and Visual Basic compatible

## Description

The MIAC is a fully specified industrial electronic controller designed to operate off 12 or 24V. It has 8 analogue or digital inputs, 4 high current relay outputs and 4 motor outputs. The MIAC is housed in an attractive, rugged, anthracite grey plastic moulding. It has two physical mounting options: it can be mounted onto a 30mm 'top hat' DIN rail, or it can be mounted directly onto any surface using the 4 screw holes provided.

The MIAC unit has screw terminal connector inputs across the top and bottom of the unit, has several input buttons for user control, and also has a 4 line 16 character alphanumeric display on the top of the unit to display system status and assist users.

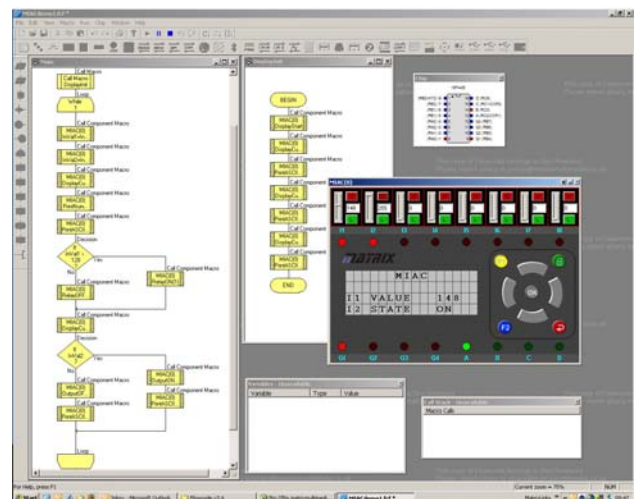

Flowcode- the graphical programming language supplied with MIAC

The unit is programmed directly from a PC's USB port and is compatible with the Flowcode graphical programming language. Users can develop a program using Flowcode, press the Reset button on the back of the unit, and the program will automatically download and start. The MIAC can also be programmed in C and assembly code, or any program that is compatible with PICmicro microcontrollers.

MIAC is equipped with a fully operational CAN bus interface so that several MIACs can be networked together to form wide area electronic systems.

A DLL and sample programs are provided to enable MIAC to be used with PC based control programs like LabView, Visual Basic, C++ etc.

# MIAC applications

## Industrial applications

MIAC is a fully specified industrial controller suitable for a wide variety of system control applications in automation, manufacturing, test, and control. The physical characteristics allow for mounting on industry standard DIN 'top hat' rails or the device can be mounted directly onto any surface. The input output circuitry has been developed with industrial control in mind, taking into account the noisy electrical environments and the rugged physical and electrical requirements of the shop floor. The flexibility of the unit make it a useful addition to the industrial engineer's standard toolbox kit.

MIAC is certified to DVE0631 and EN50178/EN60068.

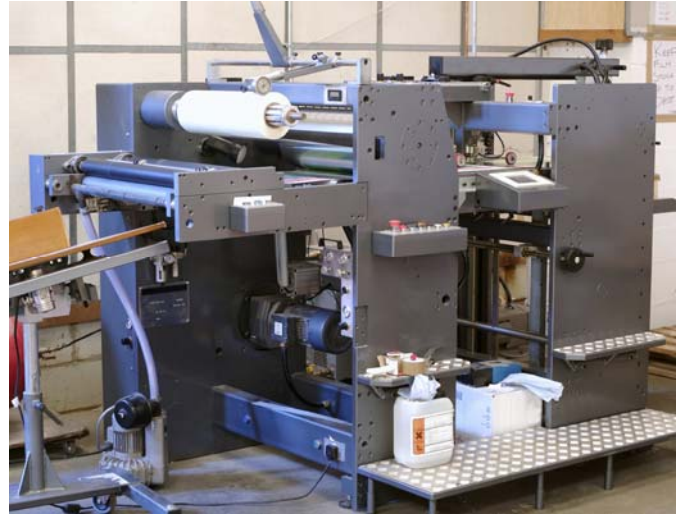

## Sensing, monitoring and control

MIAC is equipped with 8 inputs which can be used in environments where real world quantities need measuring and processes controlling. Inputs are compatible with a wide range of 0 - 10V industrial analogue and digital sensors. Flowcode software provided with MIAC allows for easy arbitration between analogue and digital inputs and decision making in control programs.

The internal CAN bus circuitry - and accompanying Flowcode CAN bus software - allow multiple MIACs to be networked together across a factory floor to add sensors up to 500m away from the central host, and to form wide area sense and control systems for food processing, liquid flow monitoring and control, alarm



## Education and training

MIAC is designed with ease of use and education/training in mind. The combination of flexible inputs, both relay and motor driver outputs in one package, internal short circuit protection, and LED status indicators on all inputs and outputs, make the MIAC an ideal controller for many fields of technical and automotive education. Flowcode software is well recognised as a leader in educational technology world-wide. Flowcode includes full simulation modes that allow students to 'see' their program working on-screen before downloading, and includes 'drivers' for MIAC so that students with no previous programming experience can develop complex electromechanical systems using the combination of MIAC and Flowcode. Flowcode is available in more than 20 languages so that students can program MIAC in their own language.



# Hardware details

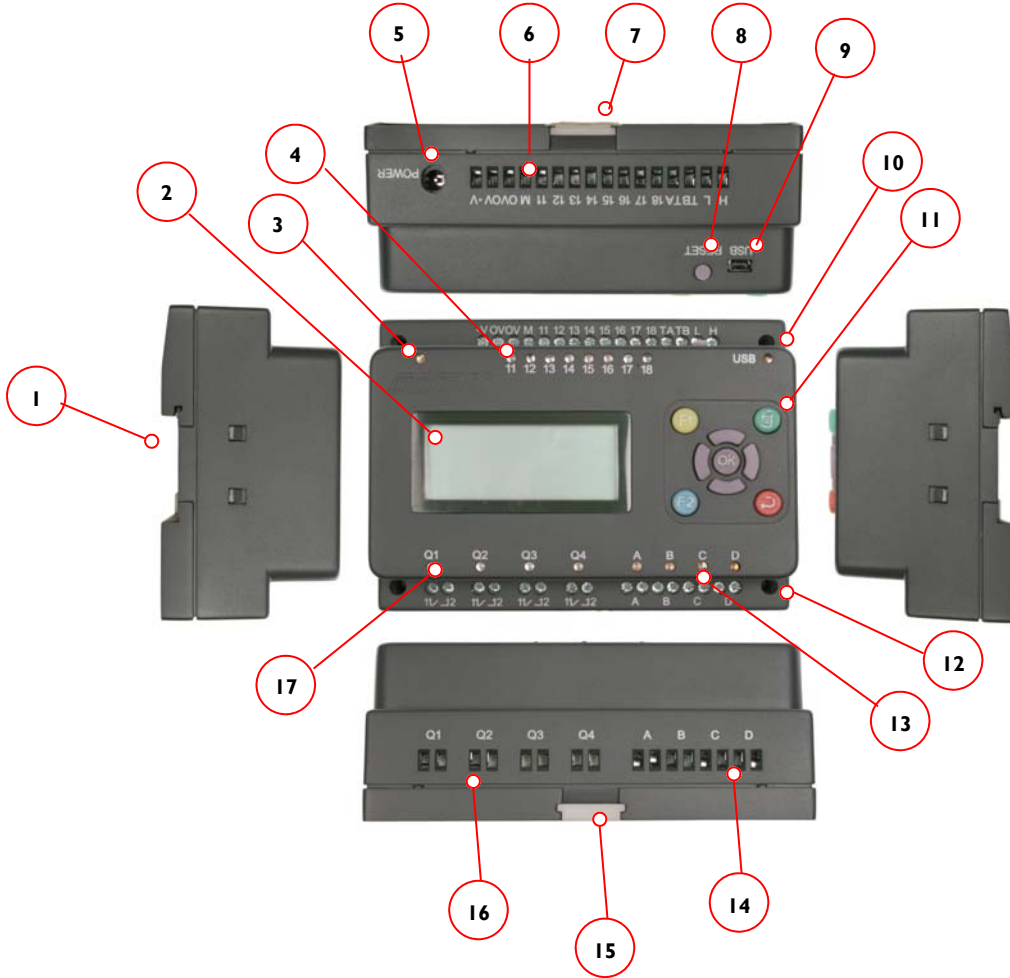

## Key

1. Top hat rail mounting recess
2. 16 character x 4 line LCD display
3. Power LED
4. Input status LEDs
5. 2.1mm power jack
6. Screw terminal inputs
7. Top hat rail retainer clip - upper
8. Reset / run switch
9. USB socket
10. USB transfer LED
11. Control keys
12. M3 mounting holes
13. Motor status LEDs
14. Motor output screw terminals
15. Top hat rail retainer clip - lower
16. Relay output screw terminals
17. Relay output status LEDs

## Internal schematic

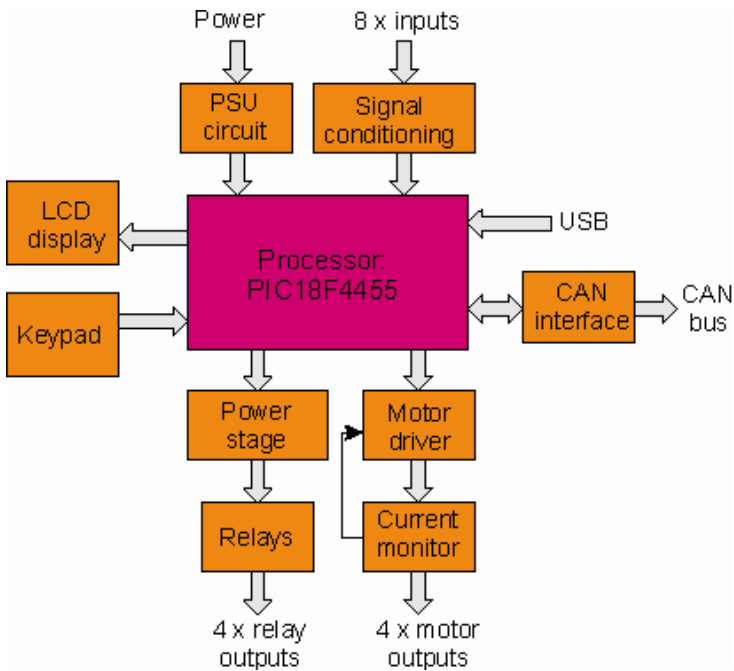

Internally the MIAC is powered by a powerful 18 series PICmicro device which connects directly to the USB port for fast programming. The PIC device is pre-programmed with a bootloader and a Windows utility is provided which allows programmers to download PIC compatible hex code into the device.

Inputs are fed into a signal conditioning circuit which allows them to be used as both analogue and digital inputs. (Not optically isolated.) Signal conditioning powers the topside LEDs which show analogue inputs at the appropriate brightness.

The outputs from the PIC processor are fed into a power stage which provides current amplification before feeding them to 4 separate relays. Fusing for relay circuits should be provided externally. Additional outputs are fed into a motor driver stage and current monitor with shutdown circuitry which limits the output current and protects the motor driver chip in case of short circuits. Output status is reflected by topside LEDs - for motor outputs LED brightness reflects motor speed / PWM ratio.

The PIC processor also connects to a two wire CAN bus driver circuit which allows several MIACs to be connected together to form an industrial control network.

Control and monitoring of processes is facilitated by a 4

# Flowcode software

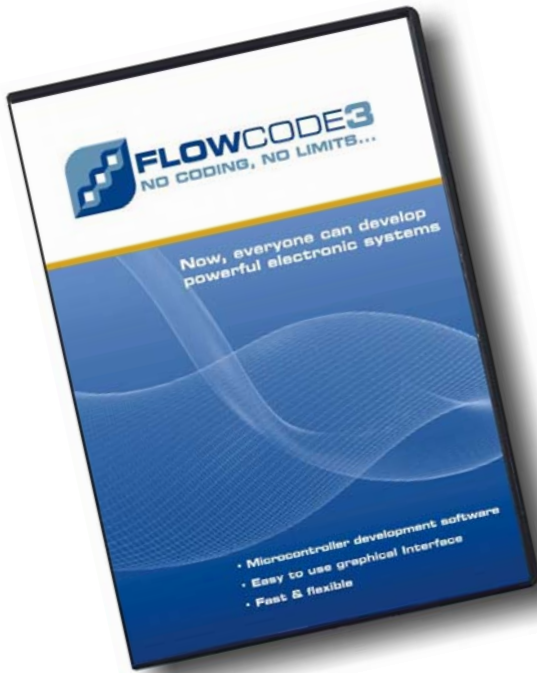

MIAC is fully compatible with Flowcode 3 - one of the world's most advanced graphical programming languages. The great advantage of Flowcode is that it allows those with little experience to create complex systems in minutes. Flowcode achieves this in two steps: firstly users drag and drop flowchart symbols onto the screen, and fill in the dialog boxes when prompted. Then Flowcode compiles the flow chart into code that is downloaded to the MIAC which executes the program.

To assist first time users a range of off the shelf routines is provided that allows system developers to get up and running without any knowledge of how the circuitry inside the MIAC works.

In addition a 12 page starter guide shows how to develop a range of programs from turning a single output on through to motor speed

adjustment under keypad control.

Within Flowcode a simulation model is provided that shows step by step program execution along with a complete simulation of the MIAC unit. This assists in both learning how the MIAC operates, and in developing programs.

Flowcode is available in many languages including: Danish, Dutch, English, Finnish, French, German, Greek, Spanish, Italian, Mandarin, Romanian, Hungarian, Solvenian, Vietnamese and Thai.only).

## Design

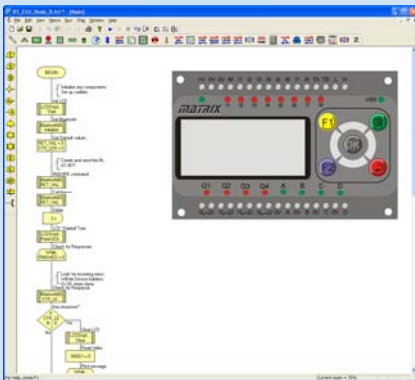

Flowcode contains standard flow chart icons and electronic components that allow to you to create a virtual electronic system on screen. Drag icons and components onto the screen to create a program, then click on them to set properties and actions.

- Easy to use interface
- Allows complex programs to be developed and managed quickly
- All I/O and expansion options are supported in Flowcode

## Simulate

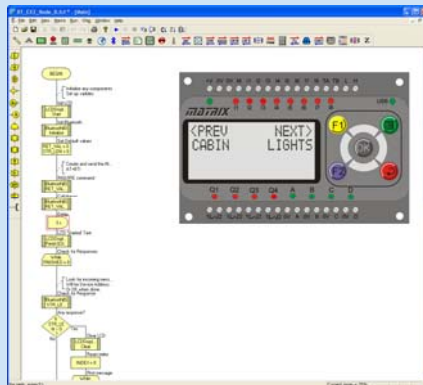

Once your system is designed you can use Flowcode to simulate it in action. Test MIAC functionality by clicking on switches or altering sensor or input values, and see how your program reacts to the changes in the electronic system.

- Simulation aids understanding
- Debug before download
- Shorten the design cycle

## Download



When you are happy with your design click one button to send the program directly to the MIAC device. Press the reset button and your program starts to run.

- One button download
- Fast action
- Flexible and expandable

# Support

## Sample files

To help you get started with programming the MIAC a wide range of sample programs are available - from getting your first input to using the customisable keypad to control motor speed.

The example list includes:

OUT1	simple relay Q1 output
OUT2	relay Q1 on for 10 seconds after F1 pressed
OUT3	relay Q1 on until sensor 1 reached half scale
DISPLAY1	shows how simple display messages are made
DISPLAY2	shows how all four lines of the display can be used
DISPLAY3	shows how the display and the keypad are used to control programs
DISPLAY4	shows how the display and keypad are used to enter parameters using up, down, left and right keys and for more complex menu systems
SENSOR1	shows analogue temperature sensor values on the LCD display
SENSOR2	shows how a digital proximity sensor is used to activate a machine using Q1
MOTOR1	shows simple motor control
MOTOR2	shows speed control of one motor under keypad control
MOTOR 3	shows stepper forwards and backwards control
MOTOR4	shows stepper speed control
MOTOR5	shows how an external rotary encoder is used to achieve speed control of a motor
CLOCK1	shows a real time clock implementation
CLOCK2	shows real time clock implementation with keypad time and date adjustment
GARAGE1	shows garage door implementation
ALARM1	shows burglar alarm implementation
ALARM2	shows burglar alarm implementation with remote CAN connected unit
GARAGE2	shows integration of GARAGE1 with ALARM2
PRESS1	shows operation of a stamping press with two operator safety switches
LVINT	LabView interface
VBINT	Visual Basic interface

Each of these is accompanied, where relevant, by a wiring diagram showing how the MIAC is connected into the system

## Continuing support

To help you get going with MIAC as fast as possible a 'Getting started' guide has been produced.

- This MIAC unit
- How to access the macro routines that control inputs, outputs, the keypad and the display
- Where you can get additional resources to help you to develop your programming skills further

In addition to this MIAC is backed up by an online forum where you can pose questions to our technical team.

## Getting started



To help you get going with MIAC as fast as possible a 'Getting started' guide has been produced.

This is a simple 12 page document that shows you step-by-step how to:

- How to mount the unit on a top hat rail
- How to mount the unit onto another surface
- How to connect the unit using screw terminals
- How to write your first simple program
- How to transfer the program to the MIAC unit
- How to access the macro routines that control inputs, outputs, the keypad and the display
- Where you can get additional resources to help you to develop your programming skills further

In addition to this MIAC is backed up by an online forum where you can pose questions to our technical team.

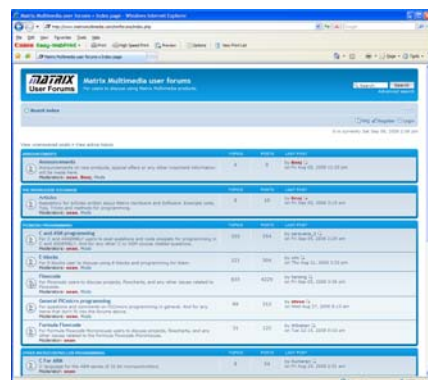

Unlimited support via our web forum

# Expansion and interfacing

## Industrial sensors

MIAC is compatible with standard industrial grade sensors that give outputs in the 0 to 10V range. Sensors that fit onto DIN rails are compatible with MIAC as can be seen from the photograph on the right.

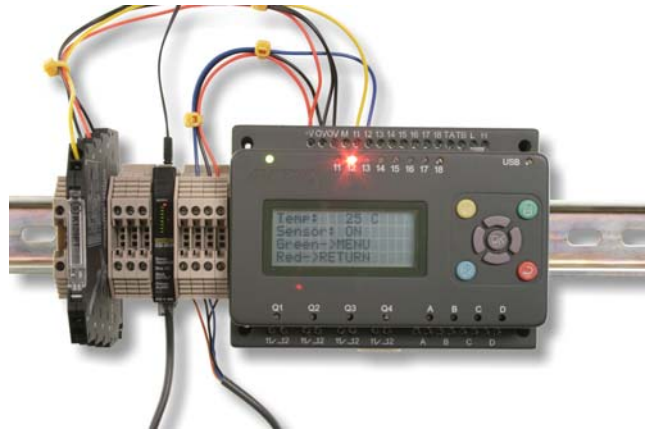

MIAC on a top hat rail with industrial sensors

## Networking

MIAC is supplied with an industrial standard CAN bus interface. This allows you to develop systems including a large number of MIACs up to 500 metres apart. Flowcode software for MIAC is compliant with both CAN 1 and CAN 2 standards which will also allow you to interface the MIAC into other systems using the CAN interface.

These features make the MIAC unit ideal for educational projects like this vehicle electrical simulator.



Automotive training panel running with two CAN connected MIAC devices.

## Use with LabView, Visual Basic and other packages

MIAC can easily be integrated with third party PC based control packages like Lab View and Visual Basic. This is enabled by a DLL and a suite of sample programs that can be downloaded to the MIAC to provide a fully controllable slave device from PC based applications.

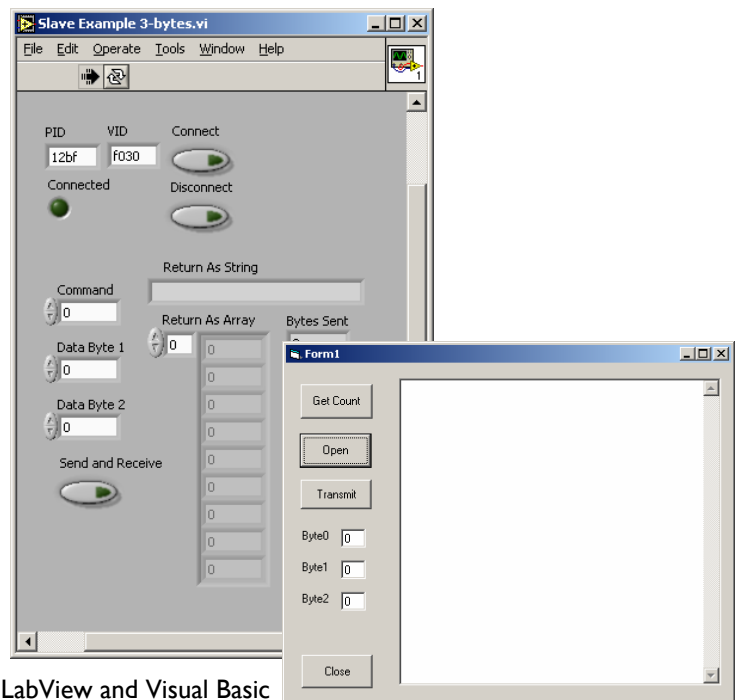

LabView and Visual Basic programs running on a MIAC

# Technical specification

Power supply	12 - 16V, <2A
Inputs	8
Inputs usable as analogue inputs	8 - 0 to 12V
Analogue input sensitivity	10mV
Input impedance	10kΩ
Input Voltage Low	0V – 3V
Input Voltage High	>7.5V
Max input voltage range	-30V, +45V
Relay outputs	4
Relay output ratings	8A at 240VAC, 30VDC
Transistor outputs (source and sink)	4
Transistor output (per channel)	500mA
Max transistor output - all channels	1.75A
Transistor thermal shutdown	>500mA
PWM outputs, sensitivity	A, C, 0.4%
Power supply	12/24V at 100mA
Storage temperature	-40 to +70C
Transistor supply voltage (M)	6 - 24V, 4A
Operating temperature	-5 to 50C
Programming interface	USB
Processor	PICmicro 18F4455, 12K ROM, 2 K RAM @48MHz
CAN bus processor	MCP2515 @20MHz

## Ordering codes

MIAC with Flowcode 3	MI0235
1A international power supply	HP5328
Flowcode V4	TEFLCSI4
USB cable	HPUAB

(MIAC is not shipped with a USB cable)

## Certified to IEC60950-1

